



ASSEMBLY, INSTALLATION, AND REMOVAL OF CONTACTS AND MODULES

FOR MINI POWER CONTACTS AND MODULES

TABLE OF CONTENTS

SECTION 1 RECEIVER CONTACT ASSEMBLY INSTRUCTIONS

SECTION 2 ITA CONTACT ASSEMBLY INSTRUCTIONS

SECTION 3 CONTACT INSTALLATION AND REMOVAL INSTRUCTIONS

SECTION 4 MODULE INSTALLATION AND REMOVAL INSTRUCTIONS

SECTION 5 CROSS REFERENCE TABLES

APPENDIX PRODUCT PERFORMANCE SPECIFICATIONS

MINI POWER RECEIVER CONTACT ASSEMBLY

PART # 610 116 112



Dimensions shown: [millimeters]
inches

ASSEMBLY INSTRUCTIONS

1. Strip wire (**Figure A**).
2. Insert a piece of 0.25" [6.35 mm] diameter shrink tubing 1.00" [25.4 mm] long onto wire.
3. Solder and clean (**Figure B**). VPC solders per IPC'S J-STD-001.
NOTE: Make sure the heat from the solder does not shrink the tubing.
4. Slide the piece of shrink tubing over the soldered end, up to the inspection hole; make sure that the inspection hole is not covered (**Figure C**).
5. Shrink the tubing.

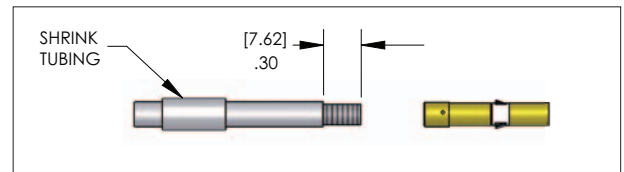

Figure A. Strip length.

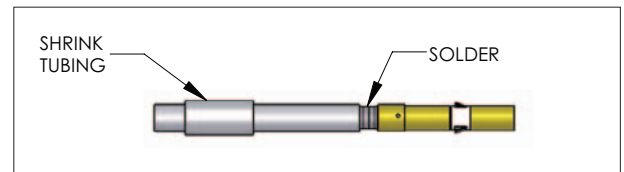

Figure B. Solder, taking care not to shrink the tubing.

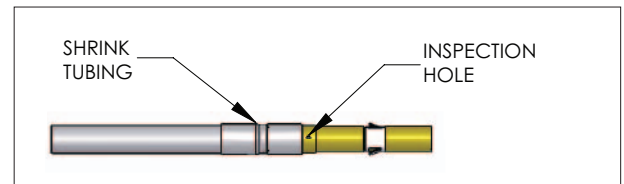

Figure C. Ensure inspection hole is not covered.

MINI POWER ITA CONTACT ASSEMBLY

PART # 610 115 124 / 610 115 125



Dimensions shown: [millimeters]
inches

ASSEMBLY INSTRUCTIONS

1. Strip wire (**Figure A**).
2. Insert a piece of 0.25" [6.35 mm] diameter shrink tubing 1.00" [25.4 mm] long onto wire.
3. Solder and clean (**Figure B**). VPC solders per IPC'S J-STD-001.
NOTE: Make sure the heat from the solder does not shrink the tubing.
4. Slide the piece of shrink tubing over the soldered end, up to the inspection hole; make sure that the inspection hole is not covered (**Figure C**).
5. Shrink the tubing.

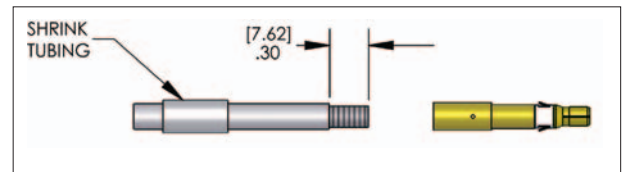

Figure A. Strip length.

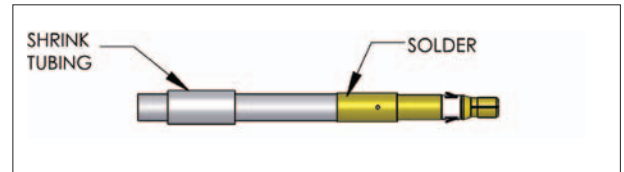

Figure B. Solder, taking care not to shrink the tubing.

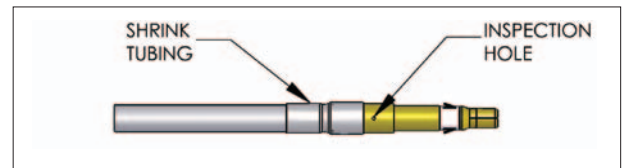

Figure C. Ensure inspection hole is not covered.

MINI POWER RECEIVER CONTACT INSTALLATION AND REMOVAL

PART # 610 116 112

TOOLS REQUIRED

Flat Blade Screwdriver
Phillips Head Screwdriver (for iCon modules)
Mini Coaxial/Mini Power Receiver/ITA Contact Extraction Tool,
Part # 910 112 104

CONTACT INSTALLATION INSTRUCTIONS

1. Assemble the contact to the respective wire.
NOTE: For more information concerning the contact assembly process please see contact assembly instructions in Section 1 of this User's Manual.
2. Insert the assembled contact into the back (wiring side) of the assembled module. Once in place, pull the wire slightly to ensure that the contact is seated.

CONTACT REMOVAL INSTRUCTIONS

1. Remove the module from the receiver frame.
NOTE: For more information concerning the process of removing the module from the receiver frame, see module installation and removal instructions in Section 4 of this User's Manual.

NOTE: Some Mini Power receiver modules are one piece modules. If your module does not have two flat head or Phillips screws holding the module together, skip to step 4.

2. Use a flat blade screwdriver (Phillips for iCon modules) to remove the screws located at the top and bottom of the module.
3. Grasp the module halves and apply force in opposite directions, rocking the ends of the module while slightly pulling the top of the module away from the mating bottom section, until separated. Be sure to open both sides of the module simultaneously or contacts could be damaged.
4. Place the Mini Coax/Mini Power Receiver/ITA Contact Extraction Tool, Part # 910 112 104 (**Figure A**), over the contact to be removed/ replaced. Use care to keep the tool perpendicular to the surface of the module, otherwise the tool or contact could be bent.
5. Once the extraction tool is seated and the retaining tabs on the retaining ring are compressed, push the tool into the module (**Figure B**). The contact will be pushed out of the rear of the module.



DO NOT PUSH THE TOOL INTO THE MODULE UNTIL THE TIP OF THE EXTRACTION TOOL HAS FULLY SEATED INTO THE MODULE AND COMPRESSED THE RETAINING RING TABS ON THE CONTACT.

6. If necessary, replace the module cap using both hands to push the separated halves together. Replace and tighten the module retaining screws to a maximum torque of 1.5 in-lbs [0.17 Nm] (not required for all Mini Power modules).

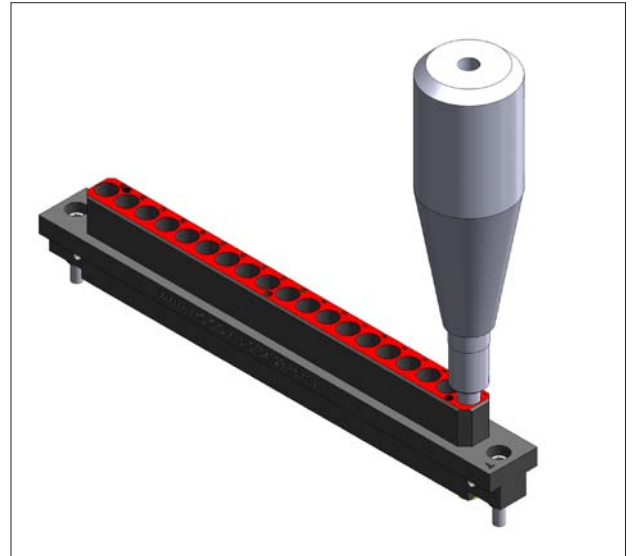

Figure A. Extraction tool, Part # 910 112 104.

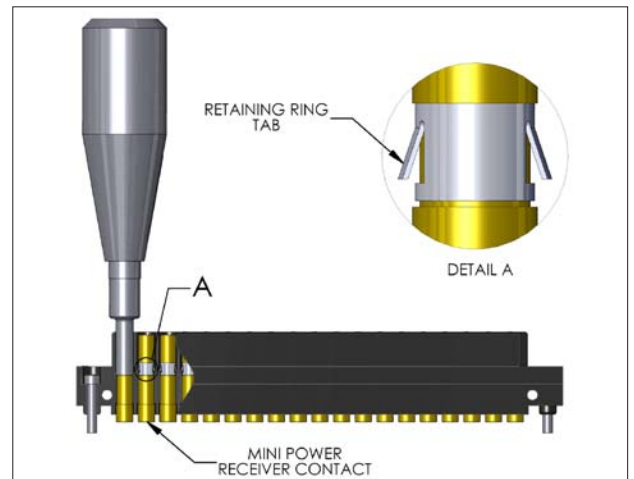

Figure B. Fully seat extraction tool before depressing.

NOTE: The process shown here uses standard/90 series modules. The same process is used for modules from other series.

NOTE: If you are using a hybrid module, you may need to reference the User's Manual for the other contact type for extraction instructions.

MINI POWER ITA CONTACT INSTALLATION AND REMOVAL

PART # 610 115 124 / 610 115 125

TOOLS REQUIRED

Mini Coaxial/Mini Power Receiver/ITA Contact Extraction Tool,
Part # 910 112 104

CONTACT INSTALLATION INSTRUCTIONS

1. Assemble the contact to the respective wire.
NOTE: For more information concerning the contact assembly process please see contact assembly instructions in Section 2 of this User's Manual.
2. Insert the assembled contact into the back (wiring side) of the module. Once in place, pull the wire slightly to ensure the contact is seated.

CONTACT REMOVAL INSTRUCTIONS

1. Remove the module from the ITA frame.
NOTE: For more information concerning the process of removing the module from the ITA frame, see module installation and removal instructions in Section 4 of this User's Manual.
2. Place the Mini Coax/Mini Power Receiver/ITA Extraction Tool, Part # 910 112 104 (**Figure A**), over the contact to be removed/replaced. Use care to keep the tool perpendicular to the surface of the module as not to bend the tool or the contact to be removed. Rotate the tool slightly while pushing it into the counter bore on the mating side of the module.
3. Once the extraction tool is seated properly and the tabs on the retaining ring are compressed (**Figure B**), push the tool into the module. The contact will be pushed out of the rear of the module.

 **DO NOT PUSH THE TOOL INTO THE MODULE UNTIL THE TIP OF THE EXTRACTION TOOL HAS BEEN FULLY SEATED INTO THE MODULE AND COMPRESSED THE RETAINING RING TABS ON THE CONTACT.**

NOTE: The process shown here uses standard/90 series modules. The same process is used for modules from other series.

NOTE: If you are using a hybrid module, you may need to reference the User's Manual for the other contact type for extraction instructions.

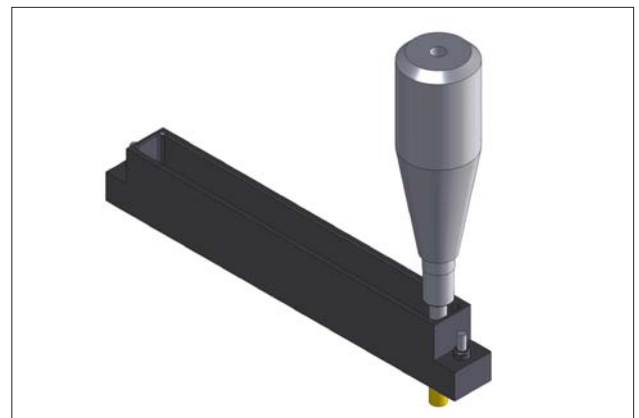

Figure A. Extraction tool, Part # 910 112 104.

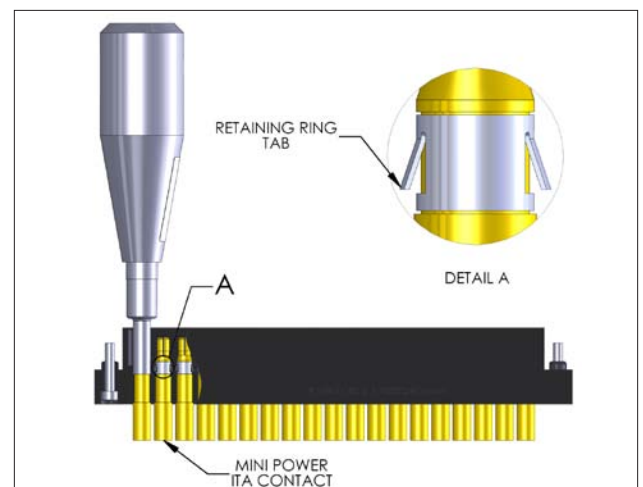

Figure B. Fully seat extraction tool before depressing.

MINI POWER STANDARD/90 SERIES MODULE INSTALLATION AND REMOVAL

TOOLS REQUIRED

$\frac{3}{32}$ Allen Wrench

INSTALLATION INSTRUCTIONS

1. Place the module in the receiver or ITA until the upper and lower module screws touch the mating holes in the inner frame. Ensure that Position 1 is located at the top for systems in which the modules are oriented vertically or to the left for systems in which the modules are oriented horizontally.
2. Using a $\frac{3}{32}$ Allen wrench, tighten the top screw 1 to 2 full revolutions, while pushing lightly against the face of the module.
3. Maintain this pressure while tightening the bottom screw 1 to 2 full revolutions.
4. Repeat this sequence until the module is seated. Torque the screw to 4 in-lbs [0.45 Nm].

REMOVAL INSTRUCTIONS

1. To remove, loosen the top screw 1 to 2 full revolutions. Loosen bottom screw 1 to 2 full revolutions.
2. Repeat this sequence until the module is separated from the receiver or ITA.

NOTE: For optimum performance and system longevity, distribute the contact load evenly throughout the module.

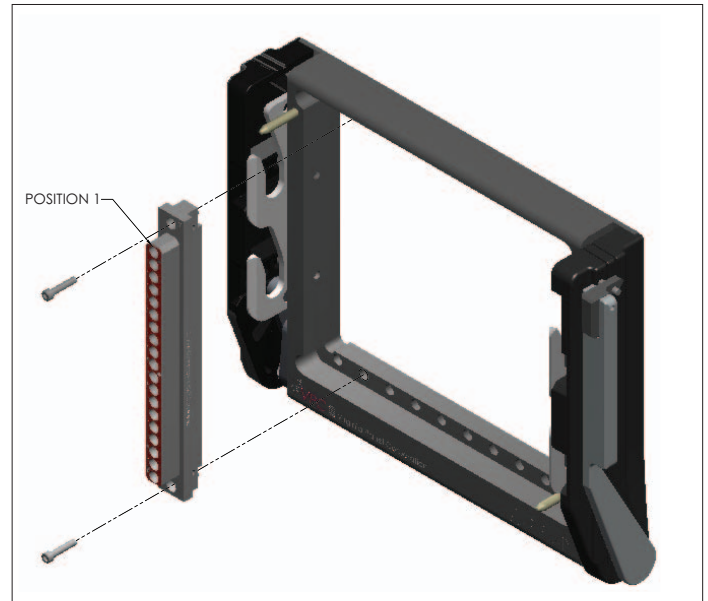

Figure A. Receiver Module.

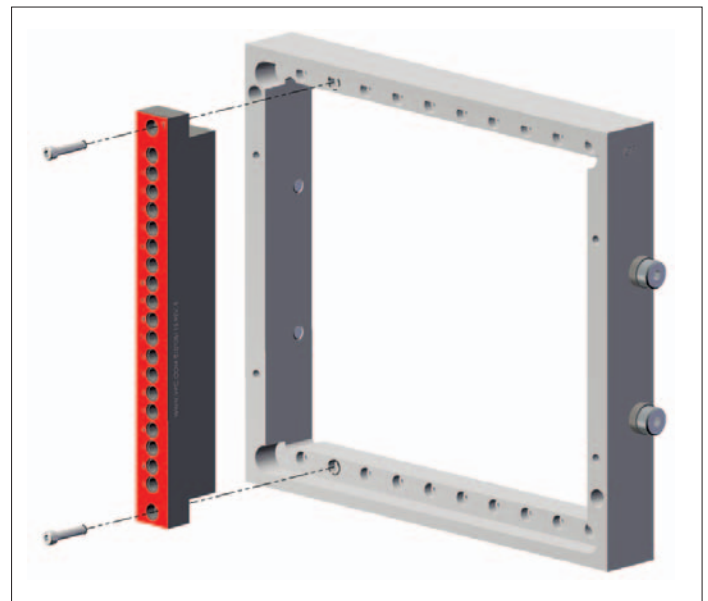

Figure B. ITA Module.

MINI POWER ICON MODULE INSTALLATION AND REMOVAL

TOOLS REQUIRED

Phillips Head Screwdriver

INSTALLATION INSTRUCTIONS

Note: The receiver strain relief plate or the ITA cover may need to be removed prior to installing or removing an iCon module. Please refer to the appropriate User's Manual for instructions on how to perform these steps.

1. Place the module in the receiver or ITA until the upper and lower module screws touch the mating holes in the inner frame. Install modules such that Position 1 is located at the top of the ITA/ receiver frame.
2. Using a Phillips head screwdriver, tighten the top screw 1 to 2 full revolutions, while pushing lightly against the face of the module.
3. Maintain this pressure while tightening the bottom screw 1 to 2 full revolutions.
4. Repeat this sequence until the module is seated. Torque the screw to 1.5 in-lbs [0.16 Nm].

REMOVAL INSTRUCTIONS

1. To remove, loosen the top screw 1 to 2 full revolutions. Loosen bottom screw 1 to 2 full revolutions.
2. Repeat this sequence until the module is separated from the receiver or ITA.

NOTE: For optimum performance and system longevity, distribute the contact load evenly throughout the module.

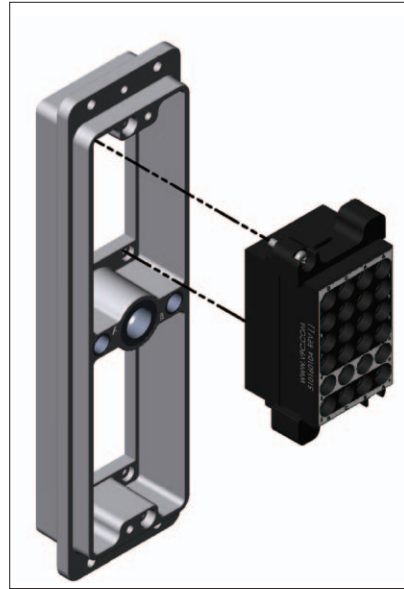

Figure A. Receiver Module.

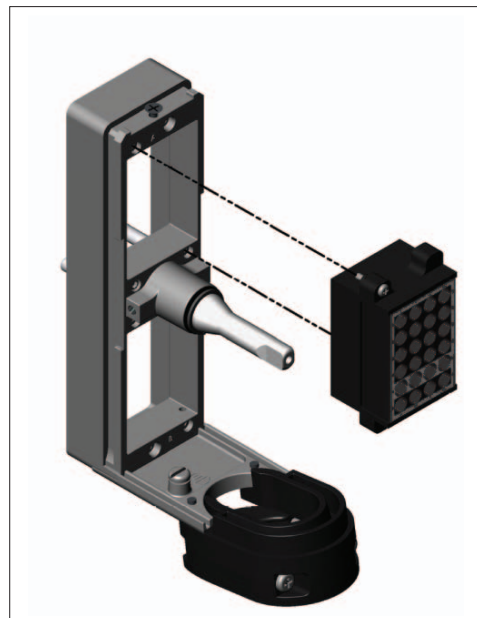

Figure B. ITA Module.

CROSS REFERENCE TABLES

RECEIVER CONTACTS	STANDARD/ 90 SERIES RECEIVER MODULES		CASS/ 80 SERIES RECEIVER MODULE	ICON RECEIVER MODULES			EXTRACTION
	510 104 123	510 104 206	510 113 120	510 160 102	510 160 103	510 160 104	910 112 104
610 116 112	X	X	X	X	X	X	X

ITA CONTACTS	STANDARD/ 90 SERIES ITA MODULES		CASS/ 80 SERIES ITA MODULE	ICON ITA MODULES			EXTRACTION
	510 108 115	510 108 178	510 114 107	510 161 102	510 161 103	510 161 104	910 112 104
610 115 124	X	X	X	X	X	X	X
610 115 125	X	X	X*	X	X	X	X

*Navy Part Number does not exist for Part # 610 115 125



Product Performance Specification

Mini Power Connector

1. Scope

1.1 Content

This specification covers the performance, tests and quality requirements for the Mini Power Connector and connector system. This contact is a separable electrical connection device. Variations of this contact can be crimped to 8, 12, 14, 16, and 18 AWG wire or soldered to wires up to 8 AWG in size. All Mini Power contact types are to be used in connector modules.

1.2 Qualification Testing

When tests are performed on subject product line, the following procedures shall be used: All inspections shall be performed using applicable inspection plans and product drawings. Upon completion of qualification testing, this specification will be assigned a number and be classified, as a Product Qualification Report which will be identified in section 2.

2. Applicable Documents

2.1 Content

The following documents form a part of this specification to the extent specified herein. Unless otherwise specified, the latest edition of the document applies. In the event of a conflict between requirements of this specification and product drawing, product drawing will take precedence. In the event of a conflict between requirements of this specification and referenced documents, this specification shall take precedence.

2.2 Documents

- A. Standards
 - EIA-364-13
 - MIL-STD-1344
 - MIL-STD-202
- B. Qualification Test Plans
 - MET ESL Test Plan #24785
- C. Product Qualification Reports
 - MET Test Report #31238T
 - VPC Test Report 2003-112
 - VPC Test Report 2005-134
- D. Product Drawings
 - Housing
 - 510104123
 - 510104246
 - 510108115
 - 510108132

Contacts

- 610116112
- 610116124
- 610116125
- 610116127
- 610115124
- 610115125
- 610115127
- 610115128
- 610115129
- 610115130
- 610115131
- 610115132

3. Requirements**3.1 Design and Construction**

Product shall be of design, construction and physical dimensions specified on applicable product drawings.

3.2 Materials

- A. Female Contact
 - Brass
 - Gold over nickel plating per MIL-DTL-45204D
- B. Male contact
 - Beryllium Copper
 - Gold over nickel plating
- C. Housing
 - G10 Epoxy Glass or Black PPS

3.3 Ratings

- A. Voltage
 - AC up to 100 MHz
 - DC
- B. Current
 - 16 AWG: 25 ampere maximum
 - 14 AWG: 30 ampere maximum
 - 12 AWG: 40 ampere maximum
 - 8 AWG: 65 ampere maximum
- C. Temperature
 - -50°C to +105°C

3.4 Performance and Test Description

Product is designed to meet electrical, mechanical, and environmental requirements specified in Figure 1. Unless otherwise specified, all tests should be performed at ambient environmental conditions.

3.5 Test Requirements and Procedures Summary

	Test Description	Requirement	Procedure
Preliminary	Examination of Product	Meets requirements of product drawing	Visual, dimensional, and functional examination per applicable quality inspection plan
Electrical	Initial Contact Resistance	< 8m Ω	Measure with digital Ohmmeter using 4 terminal method
	Current Rating	30° C maximum temperature rise	100% of pin positions populated and subjected to 65A current with 8 AWG wire
	Dielectric Breakdown	Current leak < 20 mA	1500 VDC between pins in a module for no less than 60 seconds
	Capacitance	< 3 pF	Capacitance measured between adjacent contacts in a module
Mechanical	Durability	See test sequence: Figure 2	EIA-364-9: Mate and unmate sample for 20000 cycles
	Mating Force	Max 5.7 lbs force per contact	EIA-364-13: Measure force necessary to mate samples at a normal rate of engagement of the ITA
	Unmating Force	Max 5.0 lbs force per contact	EIA-364-13: Measure force necessary to unmate samples at a normal rate of disengagement of the ITA

Figure 1. Test Requirements and Procedure Summary

3.6 Product Qualification and Requalification Test Sequence

Test or Examination	Test Group		
	I	II	III
Examination of Product	1, 9	1, 7	1, 4
Contact Resistance	2, 8	2	
Current Rating		3	
Dielectric Breakdown		4	
Capacitance		5	
Frequency Range		6	
Durability	5		
Mating Force	3, 7		2
Unmating Force	4, 6		3

Figure 2. Test Sequence

Numbers indicate the sequence in which the tests are performed. For test group sample selection see 4.1 A.

4. Quality Assurance Provisions

4.1 Qualification Testing

A. Sample Selection

Samples shall be prepared in accordance with applicable instruction sheets and shall be selected at random from current production. All test groups shall each consist of a minimum of 5 connectors containing at least 30 contacts total each and equal posts to mate with receptacles. Test group 1 shall have both minimum and maximum position size connectors.

B. Test Sequence

Qualification inspection shall be verified by testing samples as specified in Figure 2.

4.2 Re-Qualification Testing

If changes significantly affecting form, fit or function are made to product or manufacturing process, product assurance shall coordinate re-qualification testing, consisting of all or part of original testing sequence as determined by development/product, quality and reliability engineering

4.3 Acceptance

Acceptance is based on verification that product meets requirements of Figure 1. Failures attributed to equipment, test set-up or operator deficiencies shall not disqualify product. When product failure occurs, corrective action shall be taken and samples resubmitted for qualification. Testing to confirm corrective action is required before re-submittal.

4.4 Quality Conformance Inspection

A Certificate of Conformance (C of C) dimensional inspection must be completed for all samples prior to Qualification testing. The applicable quality inspection plan will specify sampling acceptable quality level to be used. Dimensional and functional requirements shall be in accordance with applicable product drawing and this specification.

Rev	Date	Rev Change	Prepared By
1	3/25/08	Original Release	Eric Husted
2	10/21/08	Updated	Eric Husted
3	6/16/09	Updated	Eric Husted
4	8/03/09	Add Crimp Contact P/Ns	Eric Husted
5	9/22/09	Updated	Eric Husted
6	1/6/12	Updated	Eric Husted

