

Contact Assembly Instructions — Section 9

Signal Terminal Assembly • TriPaddle

P/N 610 110 101 (Receiver)

P/N 610 110 125 (Receiver)

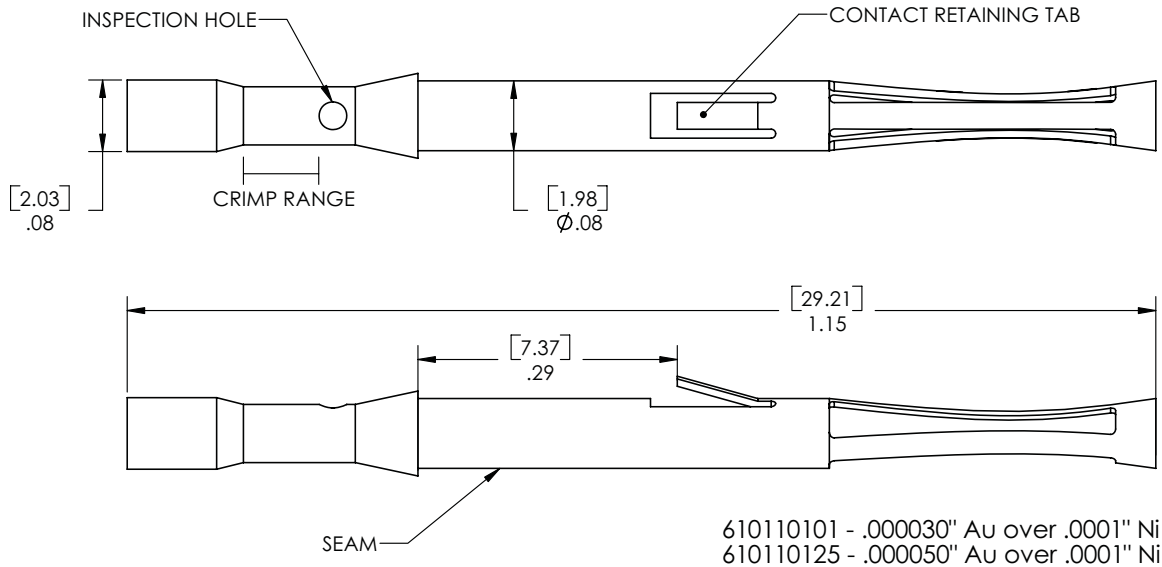

Fig. A • TriPaddle Receiver Contact, 18-24 AWG

Crimp Tool Setup

Tool P/N 910 101 103 (Fig B)

1. Set up crimp tool P/N 910 101 103 by loosening contact retainer latch assembly using the locking screw (turn counter-clockwise to loosen).
2. Insert open end of crimp contact locator P/N 910 104 127 into contact retainer assembly. Contact locator shown in Fig. C.
NOTE: Contact locator is “D” shaped with a flat at one side to allow only one possible contact locator insertion position.
NOTE: Crimp contact locator P/N 910 104 107 may also be used, but VPC recommends use of 910 104 127, as it contains an integrated wire stop feature for ease of contact crimping.
3. Slide crimp tool retaining latch to contact locator until contact locator is securely held in place and tighten latch locking screw.

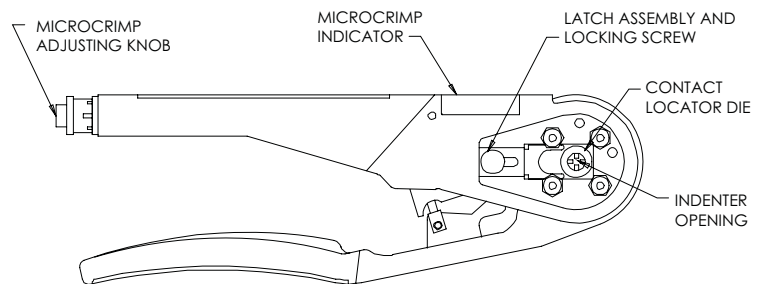

Fig. B • Part # 910 101 103

Crimp Tool Adjustment and Wire Preparation

1. Using Table 1, determine appropriate crimp tool setting for the wire gauge being used.
2. Pull and turn the microcrimp adjusting knob (clockwise to increase, counter-clockwise to decrease settings) to adjust the crimp tool until the appropriate setting is achieved.
3. Strip wire .25” +.05/-.00. Restore wires to original lay.

NOTE: Observe precision ratchet action by opening and closing crimp tool fully several times. Note that tool cannot be opened without completing cycle. Never attempt to disassemble tool. Never tighten or loosen stop nuts on back of tool.

Contact Assembly Instructions — Section 9

Signal Terminal Assembly • TriPaddle
 P/N 610 110 101 (Receiver)
 P/N 610 110 125 (Receiver)

Table 1

Wire Gauge	Crimp Max.	Crimp Min.	Pullout Force (lb.)
18 (Acceptable Stranding: 1 x 18)	.043	.039	10
20	.037	.033	10
22	.033	.029	10
24	.029	.025	8
2-24	.041	.037	8
2-26	.036	.033	4

Contact Setup and Crimping

- Align contact retaining tab (Fig A) with positioning slot (Fig C) in contact crimp locator and insert contact into crimp tool.

NOTE: Contact will drop completely into the crimp tool if properly positioned.

NOTE: Do not force contact into the crimp tool, as contact damage will occur.

NOTE: If contact does not drop completely into the crimp tool, remove the contact, ensure that the contact retaining tab is properly aligned with the contact crimp locator, and re-insert contact into crimp tool .

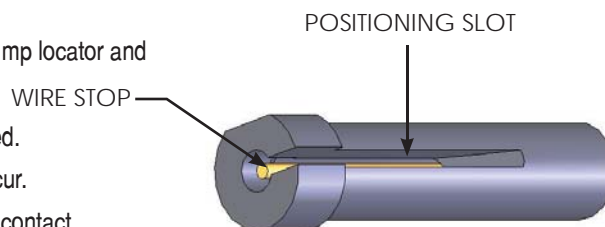

Fig. C • Part # 910 104 127

- Once contact is properly inserted into the crimp tool, squeeze crimp tool handle slightly to hold the contact in position for wire insertion.
- Insert stripped wire fully into the contact and squeeze the crimp tool handle fully until reaching a positive stop.

NOTE: For 18 AWG wire, you may insert the wire into the contact before you align the contact retaining tab and then carefully drop the contact (with the inserted wire) into the crimp tool.

NOTE: Crimp tool will automatically release and return to open position when crimp is complete.

- Remove the crimped contact.
- Verify the crimp falls within the given range as shown in Fig. A. A good crimp will be centered over the seam of the contact and the conductor wires will be visible through the inspection hole. Each crimp should hold to the pull out force listed in Table 1.

NOTE: When crimping a contact to two wires, the pullout force applies to each wire.

- VPC recommends applying .093 DIA shrink tubing, .625" long to all TriPaddle patchcords. The shrink tubing should be applied just below the inspection hole. See Fig. D.

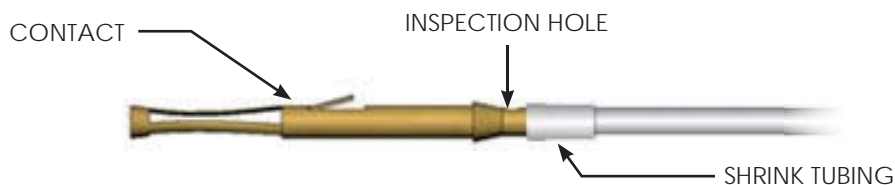

Fig. D • TriPaddle Patchcord