

i2 MICRO iCON PCB ASSEMBLY

84 PIN HEADER, PART # 510 109 204 • 60 PIN HEADER, PART # 510 109 206
MOUNTING BRACKET, PART # 310 113 562

TOOLS REQUIRED

Phillips Head Screwdriver

ASSEMBLY INSTRUCTIONS

1. Assemble two headers to the PCB. See next page for recommended PCB layout.
2. Using the Phillips head screwdriver, secure the headers and mounting bracket (Part # 310 113 562) to the PCB using the supplied 2 mm screws (**Figure A**).
3. Secure the receiver to the mounting panel (**Figure B**) following the recommended panel cutout (see Section 3).
4. Using the Phillips head screwdriver, press the PCB and headers onto the receiver and secure the mounting bracket to the receiver using the supplied 2-56 screw (**Figure C**).

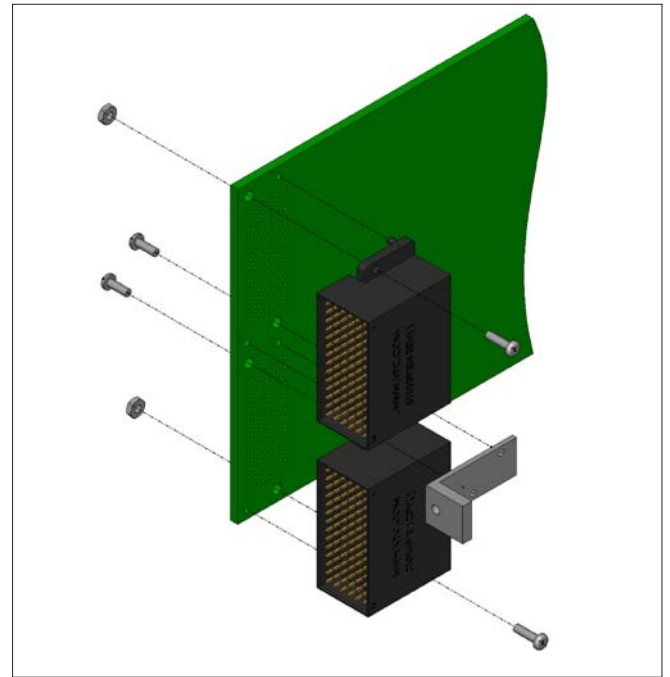

Figure A. Secure headers and mounting bracket to PCB.

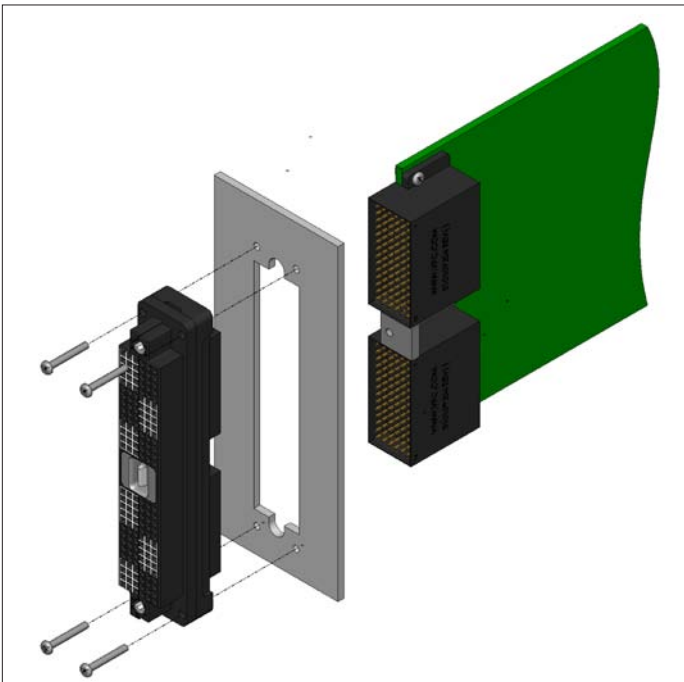

Figure B. Secure receiver to mounting panel.

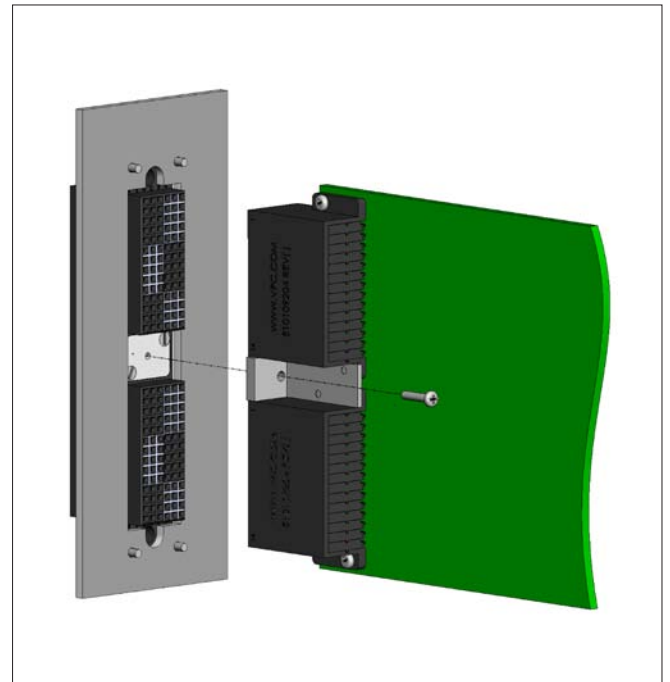

Figure C. Secure mounting bracket to receiver.

i2 MICRO iCON PCB LAYOUT

HEADER, 84 POSITION RIGHT ANGLE WITH COMPLIANT PIN • PART # 510 109 204

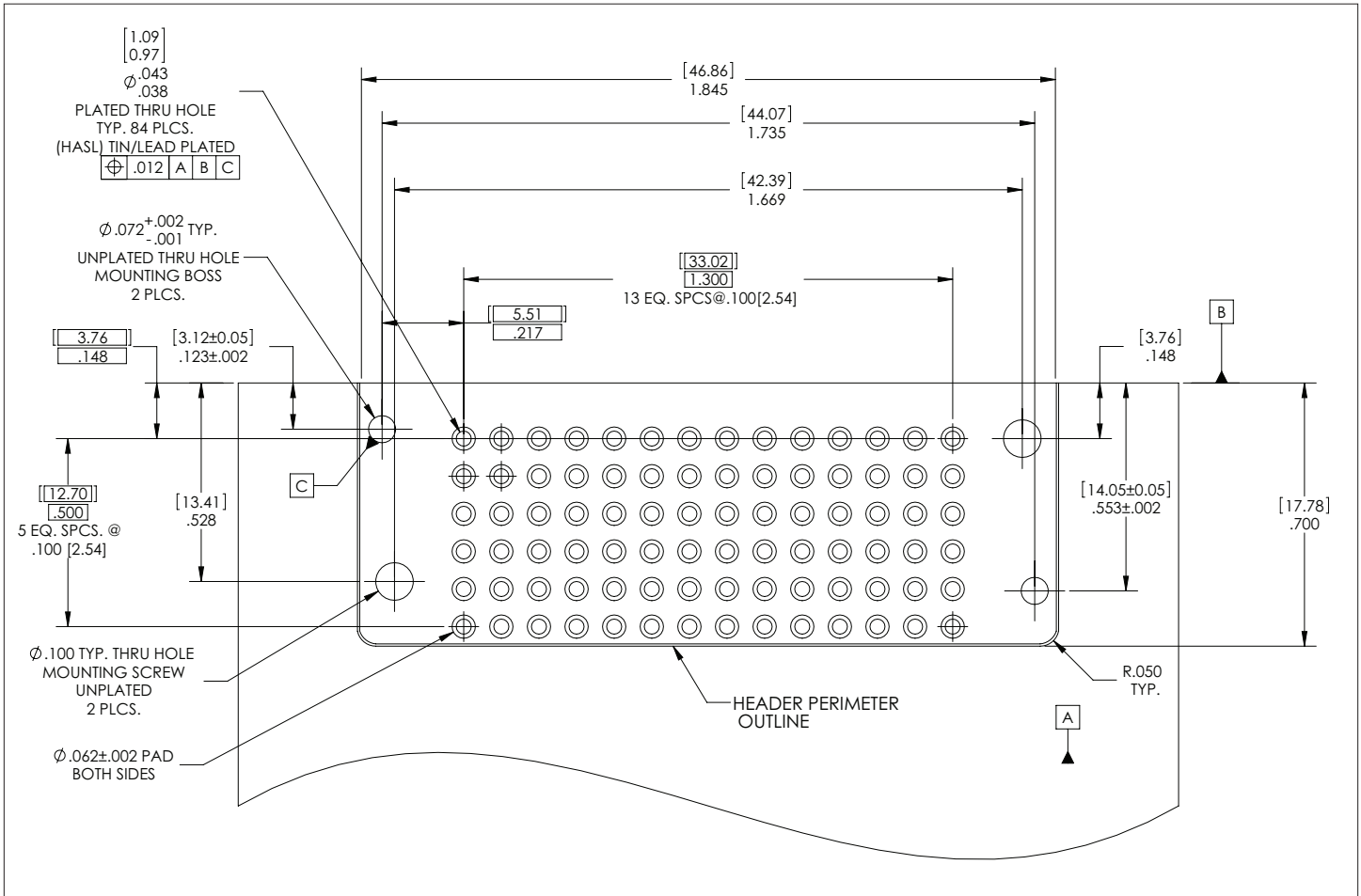

Figure A. PCB layout. Connector mounts this side.
 Board thickness = [1.57] .062
 Dimension tolerance = \pm . [13] .005 unless otherwise specified.

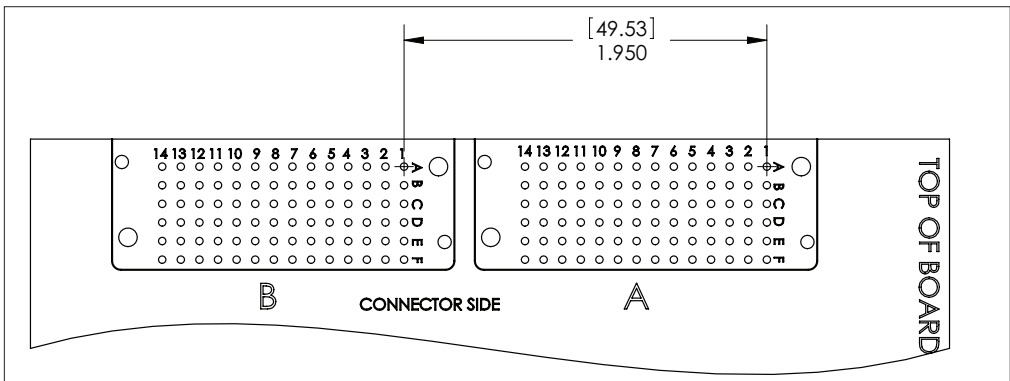

Figure B. Two header layout for 310 130 101 receiver.

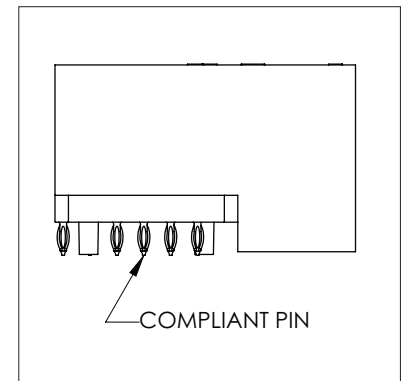

Figure C. Compliant header pin.

i2 MICRO iCON STANDARD PCB LAYOUT

i2 RECEIVER • PART # 310 130 101

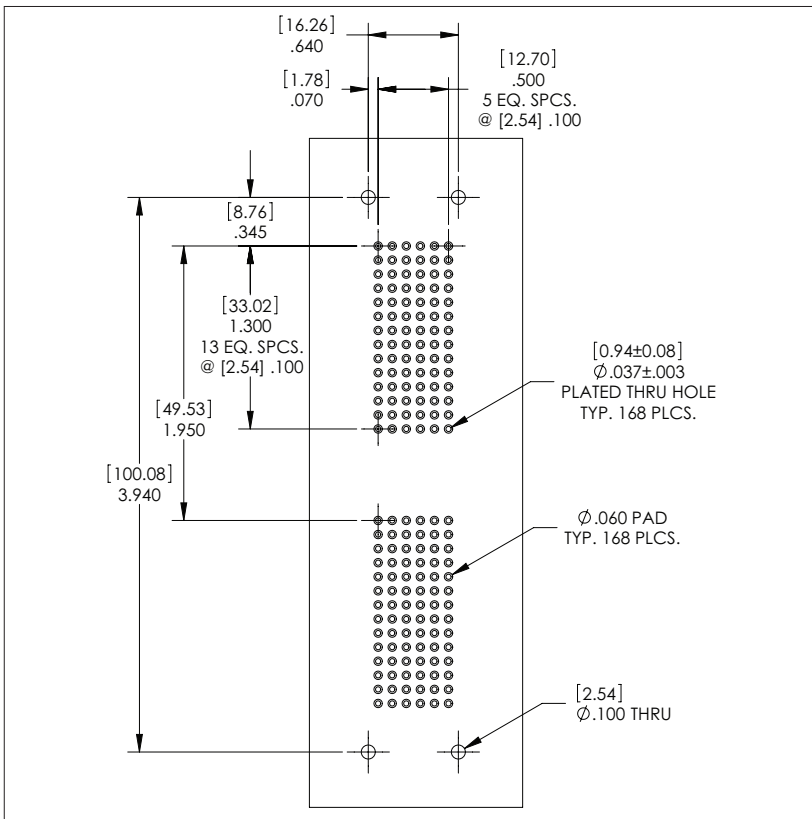

Figure A. PCB layout for i2 receiver, Part # 310 130 101. Thru hole and pad diameters are for VPC QuadraPaddle Adapter Contact, Part #610 138 117. The size of these holes may be different if a header from a different manufacturer is used.

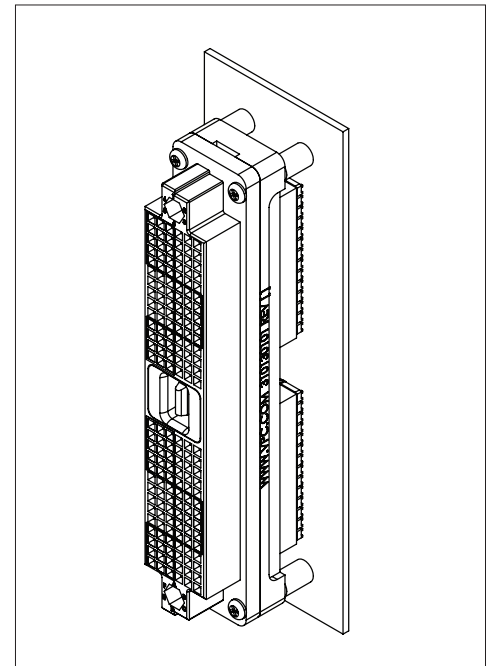

Figure B. i2 receiver, Part # 310 130 101, loaded with twin female contacts, Part # 610 138 100. Twin male headers are used to connect the female contacts to the PCB plated thru holes.

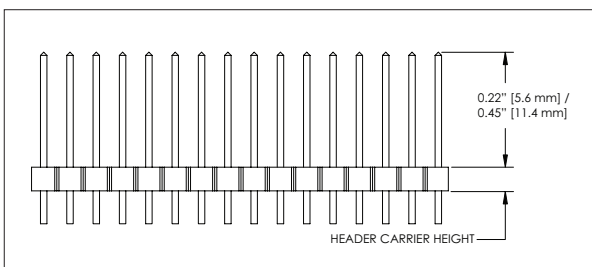

Figure C. Twin male header.

NOTE: Figure C details 0.22" [5.59 mm]/0.45" [11.43 mm] min/max engagement.
 NOTE: Minimum spacer height = 0.24" + header carrier height - panel thickness (if used).
 Any additional height beyond this minimum must be added to the header post limits shown in Figure C.

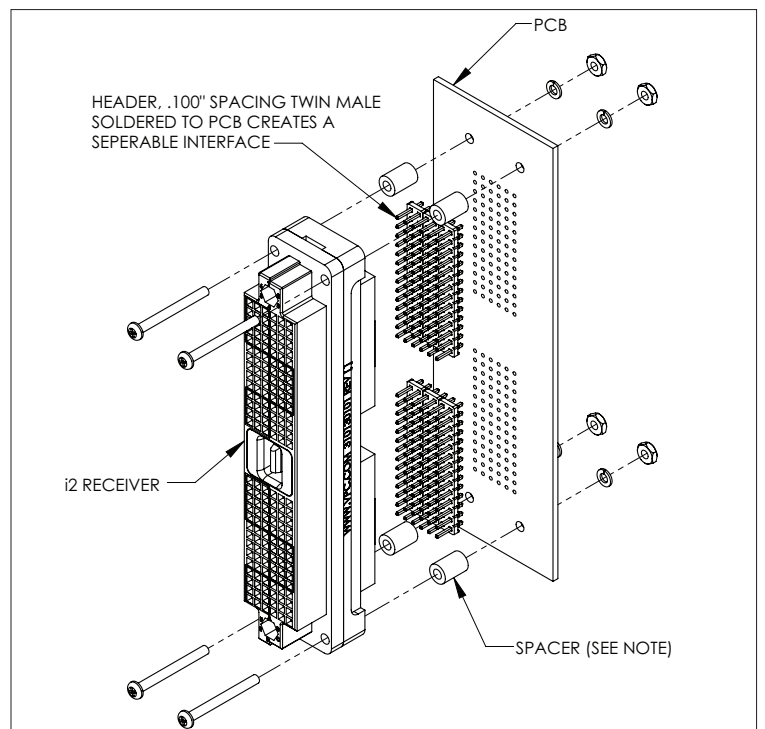

Figure D. A PCB can be mounted directly to the back of an i2 receiver as shown above. Four 2-56 or M2 screws are required to mount the receiver. Spacers may be needed to prevent unwanted stress on the PCB.

i2 HYBRID PCB LAYOUT

HEADER, 60 POSITION RIGHT ANGLE WITH COMPLIANT PIN • PART # 510 109 206

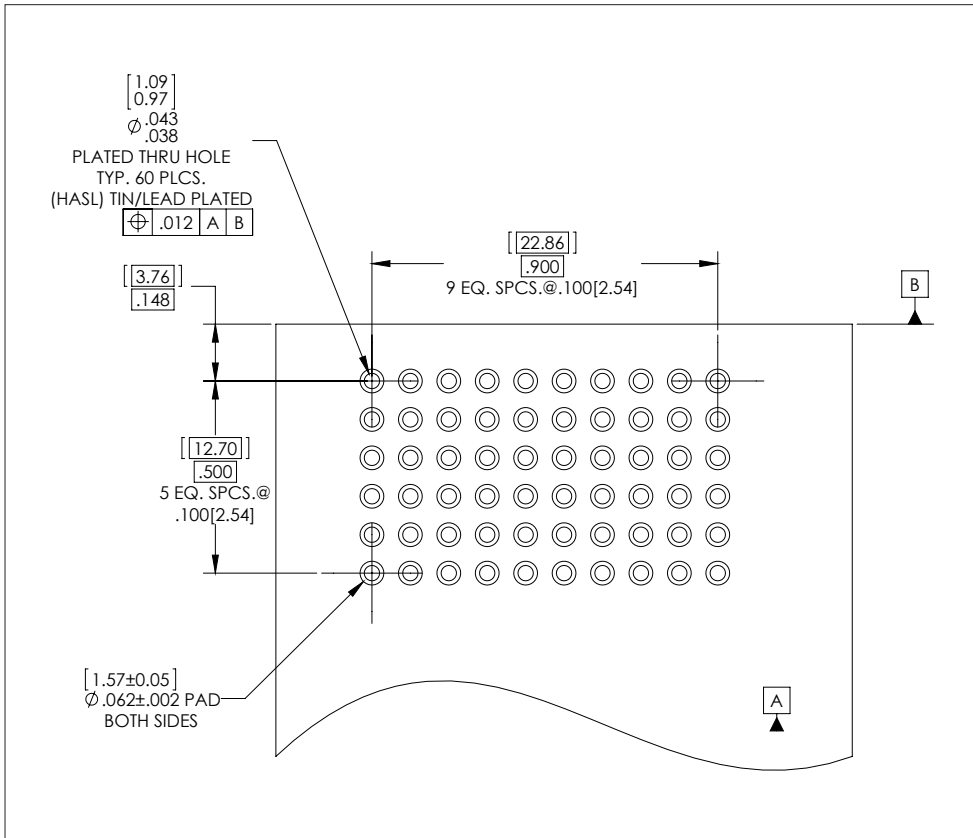

Figure A. PCB layout. Connector mounts this side.
Board thickness = [1.57] .062
Dimension tolerance = ±.[.13].005 unless otherwise specified.

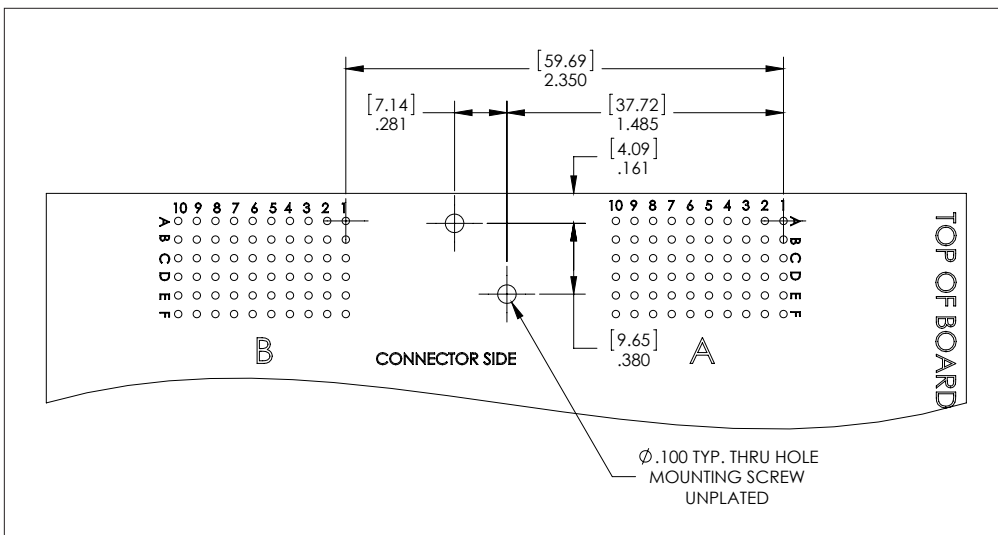

Figure B. Two header layout for 310 130 104 receiver.

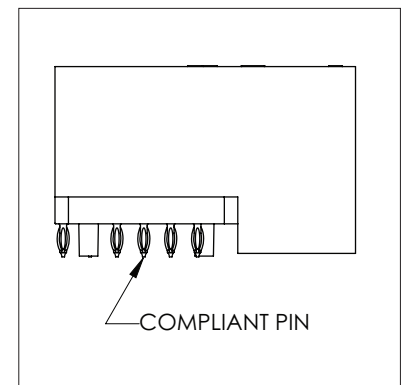

Figure C. Compliant header pin.

