

DO NOT SCALE DRAWING

THE INFORMATION CONTAINED HEREIN IS THE EXCLUSIVE PROPERTY OF VIRGINIA PANEL CORPORATION AND IS SUBMITTED FOR USE BY THE CUSTOMER ONLY. THE DATA SHALL NOT BE DUPLICATED, USED, OR DISCLOSED IN WHOLE OR IN PART FOR ANY PURPOSE OTHER THAN TO MAINTAIN THE EQUIPMENT PROVIDED. CONSULT WITH VIRGINIA PANEL CORPORATION ENGINEERING IF MORE DETAIL IS REQUIRED.

REVISIONS			
REV	DESCRIPTION	DATE	ENGR
A	ORIGINAL RELEASE; ECN 08-310-0080	10/6/08	R GARMAN

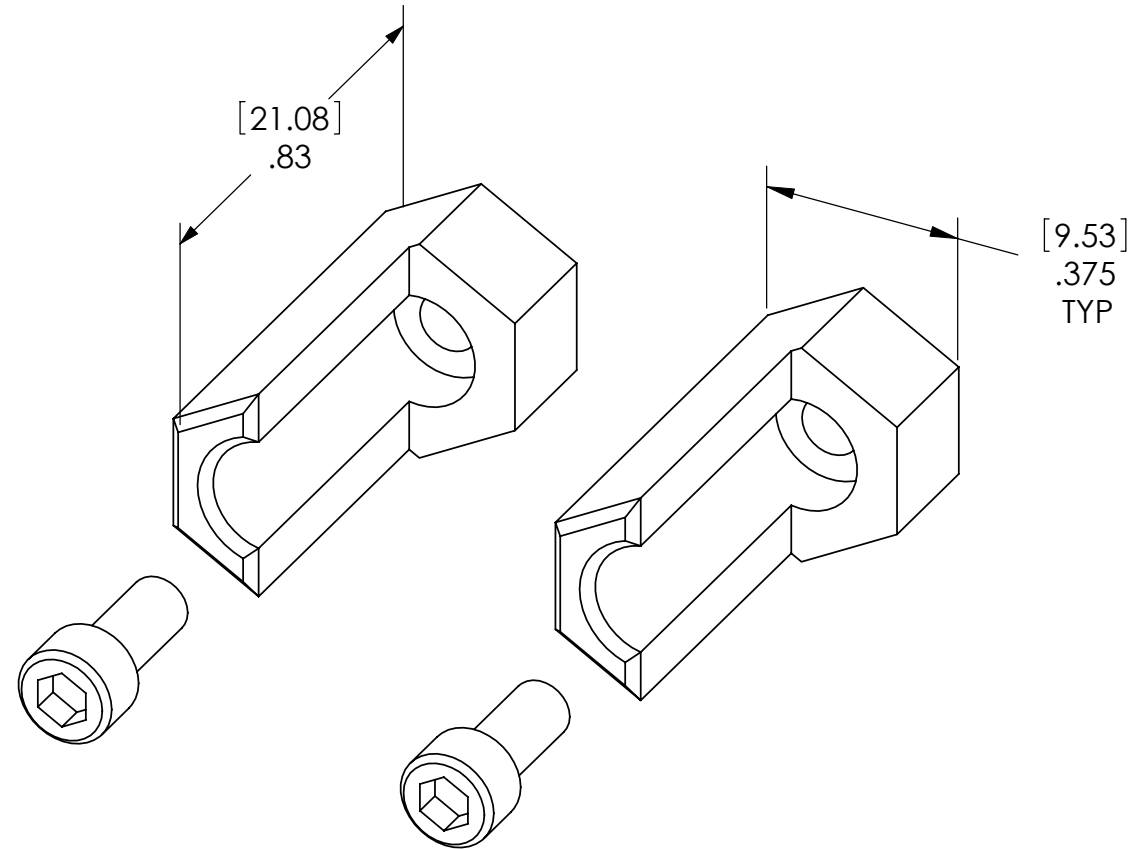

3. MATERIALS:
 KEY - ALUMINUM ALLOY
 SCREW - STAINLESS STEEL

2. EACH KIT CONTAINS 2 KEYS AND 2 MOUNTING SCREWS.

1. FOR APPLICATION USE AND CARE INFORMATION CONSULT VPC USERS GUIDE @ WWW.VPC.COM

NOTES:

CUSTOMER DRAWING			
VIRGINIA PANEL CORPORATION WWW.VPC.COM			
RCV/ITA KEYING PIN KIT			

DIMENSIONS ARE SHOWN AS: [MILLIMETERS] INCHES	SIZE	CAGE CODE	DWG.NO.	REV
	B	18117	310113501	A
SCALE: 3:1		310113501	8/1/08	SHEET 1 OF 1