

DO NOT SCALE DRAWING

THE INFORMATION CONTAINED HEREIN IS THE EXCLUSIVE PROPERTY OF VIRGINIA PANEL CORP. AND IS SUBMITTED FOR USE BY THE CUSTOMER ONLY. THE DATA SHALL NOT BE DUPLICATED, USED, OR DISCLOSED IN WHOLE OR IN PART FOR ANY PURPOSE OTHER THAN TO MAINTAIN THE EQUIPMENT PROVIDED. CONSULT WITH VIRGINIA PANEL CORPORATION ENGINEERING IF MORE DETAIL IS REQUIRED.

REVISIONS				
ZONE	REV	DESCRIPTION	DATE	APPROVED
	A	ORIGINAL RELEASE	2/13/03	

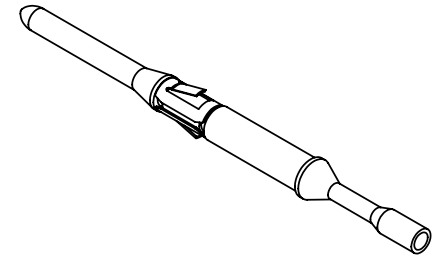
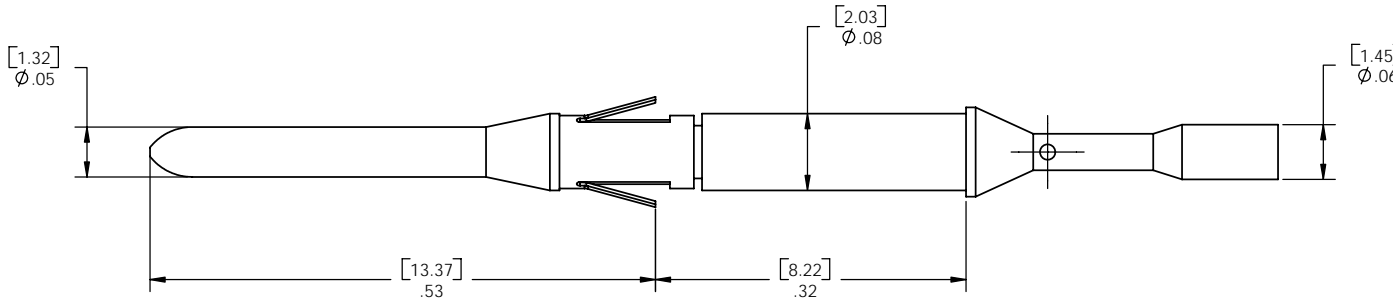

SCALE 5:1

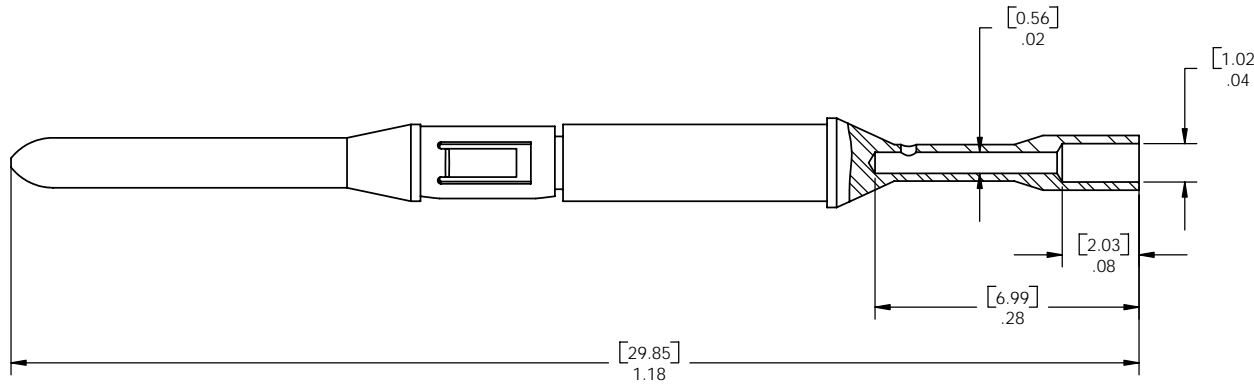

1 FOR APPLICATION, USE & CARE INFORMATION
CONSULT VPC USERS GUIDE @WWW.VPC.COM

NOTES:

CUSTOMER DRAWING - CUSTOMER DRAWING

SOLIDWORKS DRAWING FILE	DIMENSIONS ARE SHOWN AS: (millimeters) INCHES		SIGNATURES		DATE	VIRGINIA PANEL CORPORATION WWW.VPC.COM		
	DR	CHK	R	GARMAN	2/13/03			
	ENG	PROD					MALE TRIPADDLE CNT, 26-28 AWG	
	ASSY	O A					SIZE	FSCM NO.
	APPD						C	18117
FINISH		MATERIAL		SCALE: NONE		2/13/03	DWG. NO. 610110169	REV A
				2/13/03		610110169	SHEET 1 OF 1	