

DO NOT SCALE DRAWING

THE INFORMATION CONTAINED HEREIN IS THE EXCLUSIVE PROPERTY OF VIRGINIA PANEL CORPORATION AND IS SUBMITTED FOR USE BY THE CUSTOMER ONLY. THE DATA SHALL NOT BE DUPLICATED, USED OR DISCLOSED IN WHOLE OR IN PART FOR ANY PURPOSE OTHER THAN TO MAINTAIN THE EQUIPMENT PROVIDED. CONSULT WITH VIRGINIA PANEL CORPORATION ENGINEERING IF MORE DETAIL IS REQUIRED.

REVISIONS			
REV	DESCRIPTION	DATE	ENGR
B	ECN # 12743	8/2/22	M ECKERT

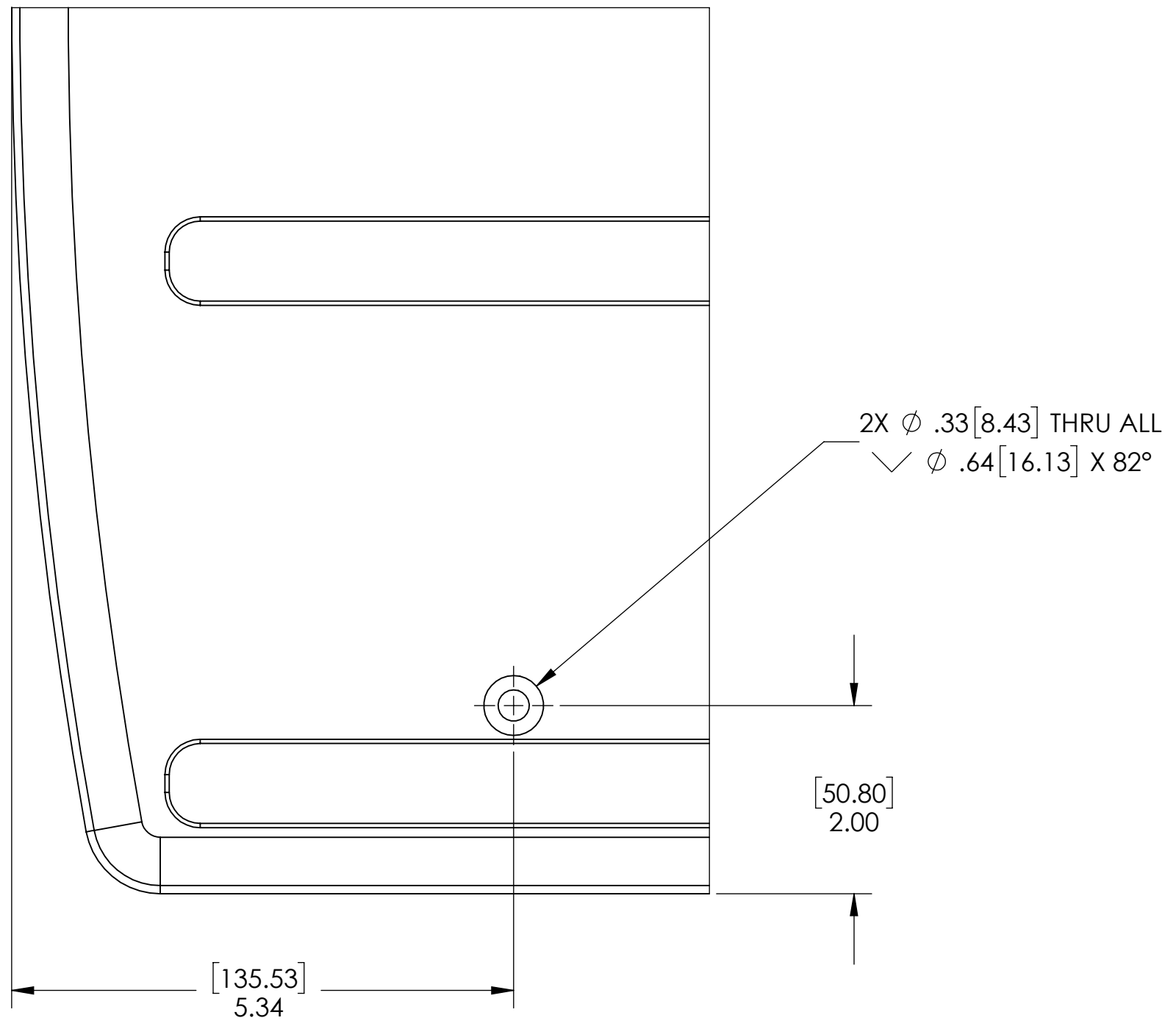

DETAIL A
SCALE 2 : 3

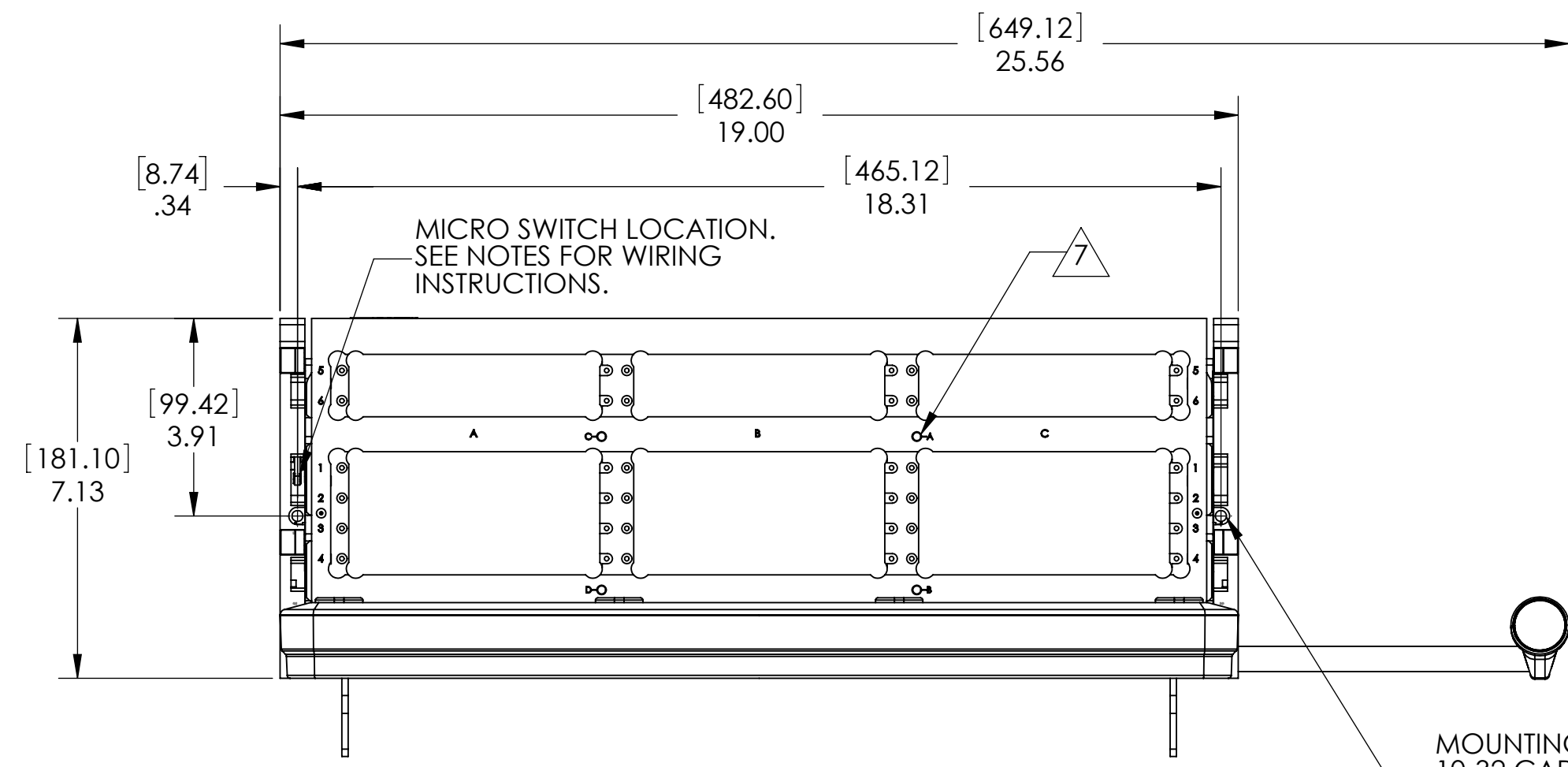
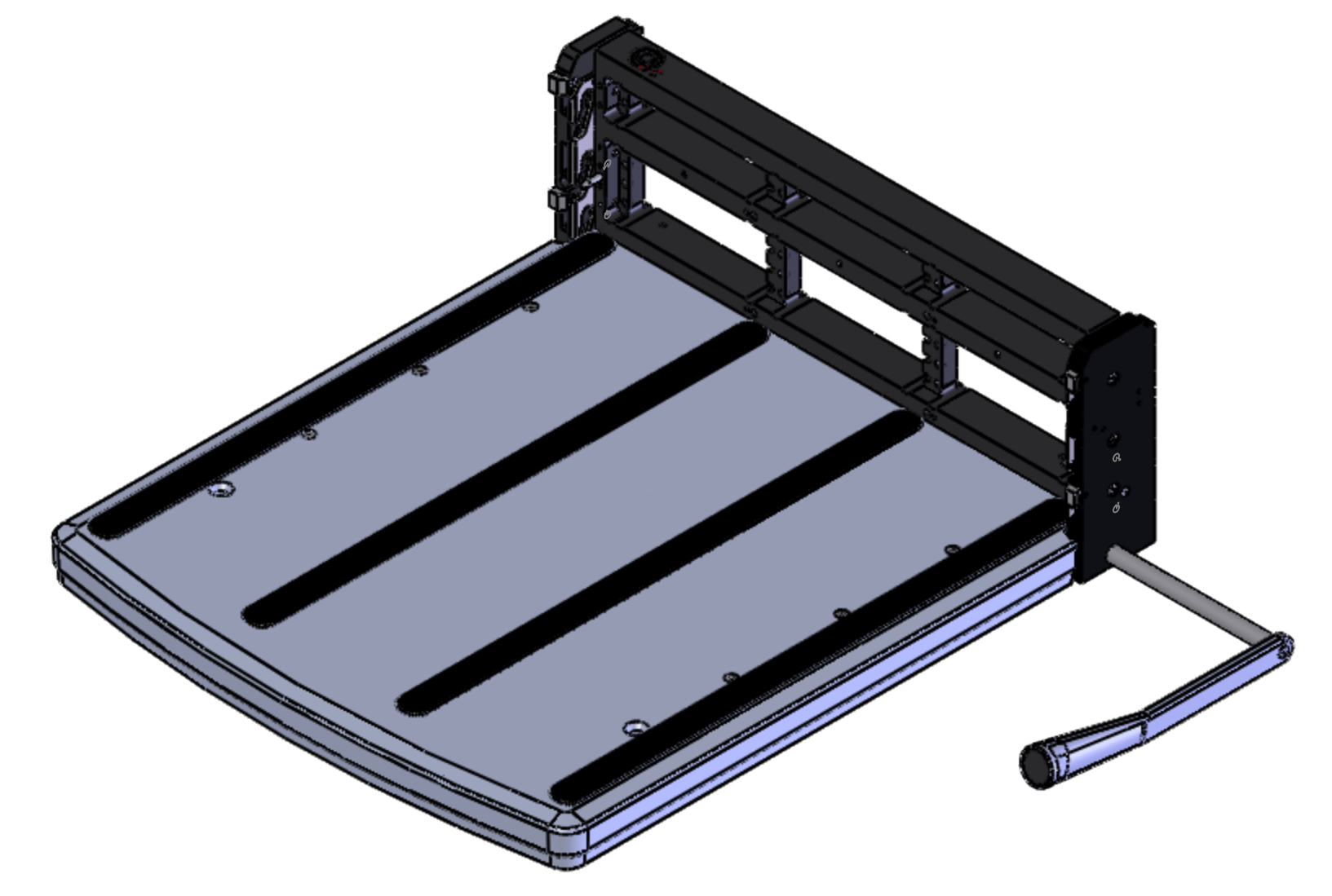
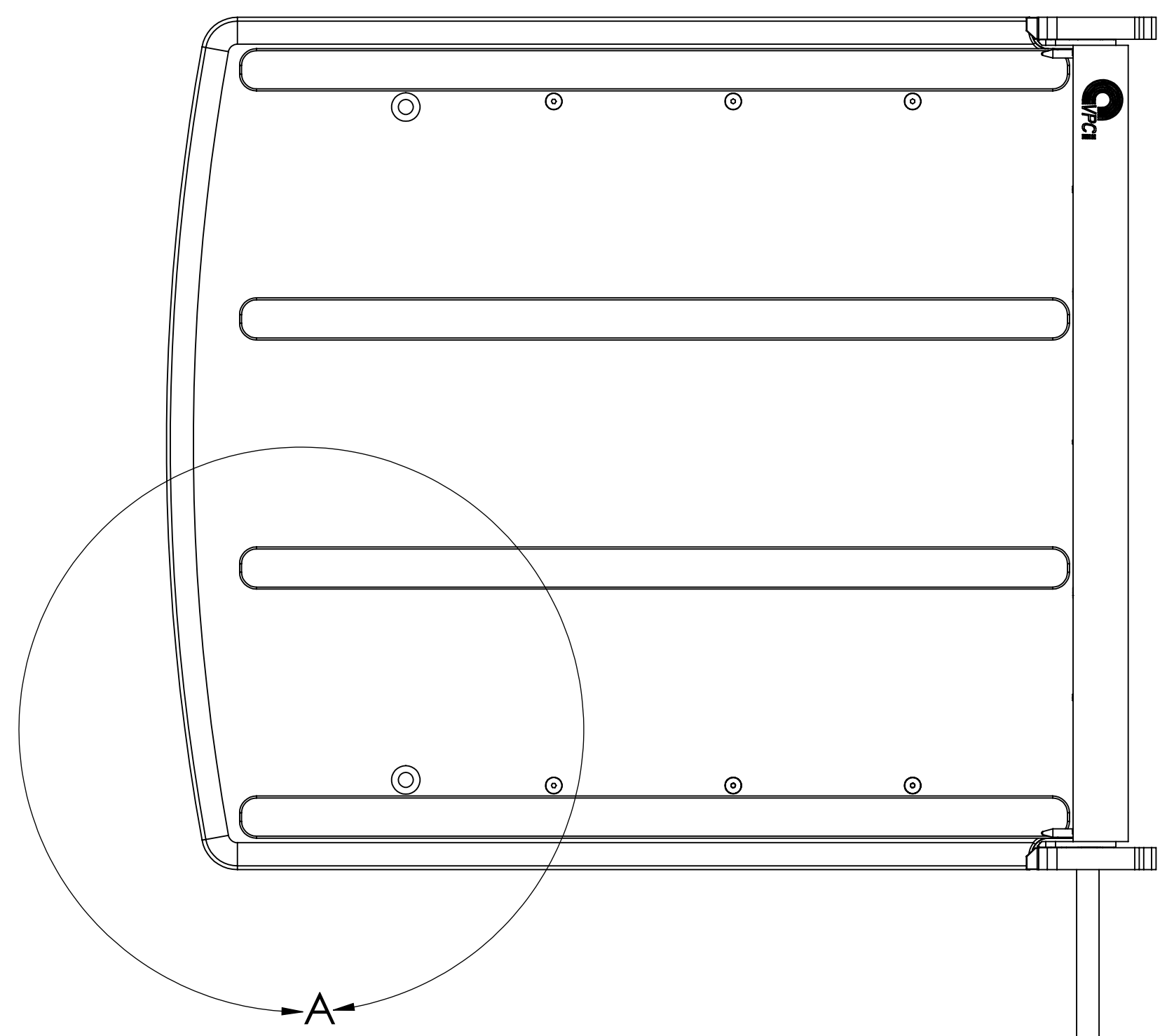

MOUNTING HOLES FOR 10-32 CAP SCREWS (INCLUDED) USED TO HOLD RECEIVER TO RACK.

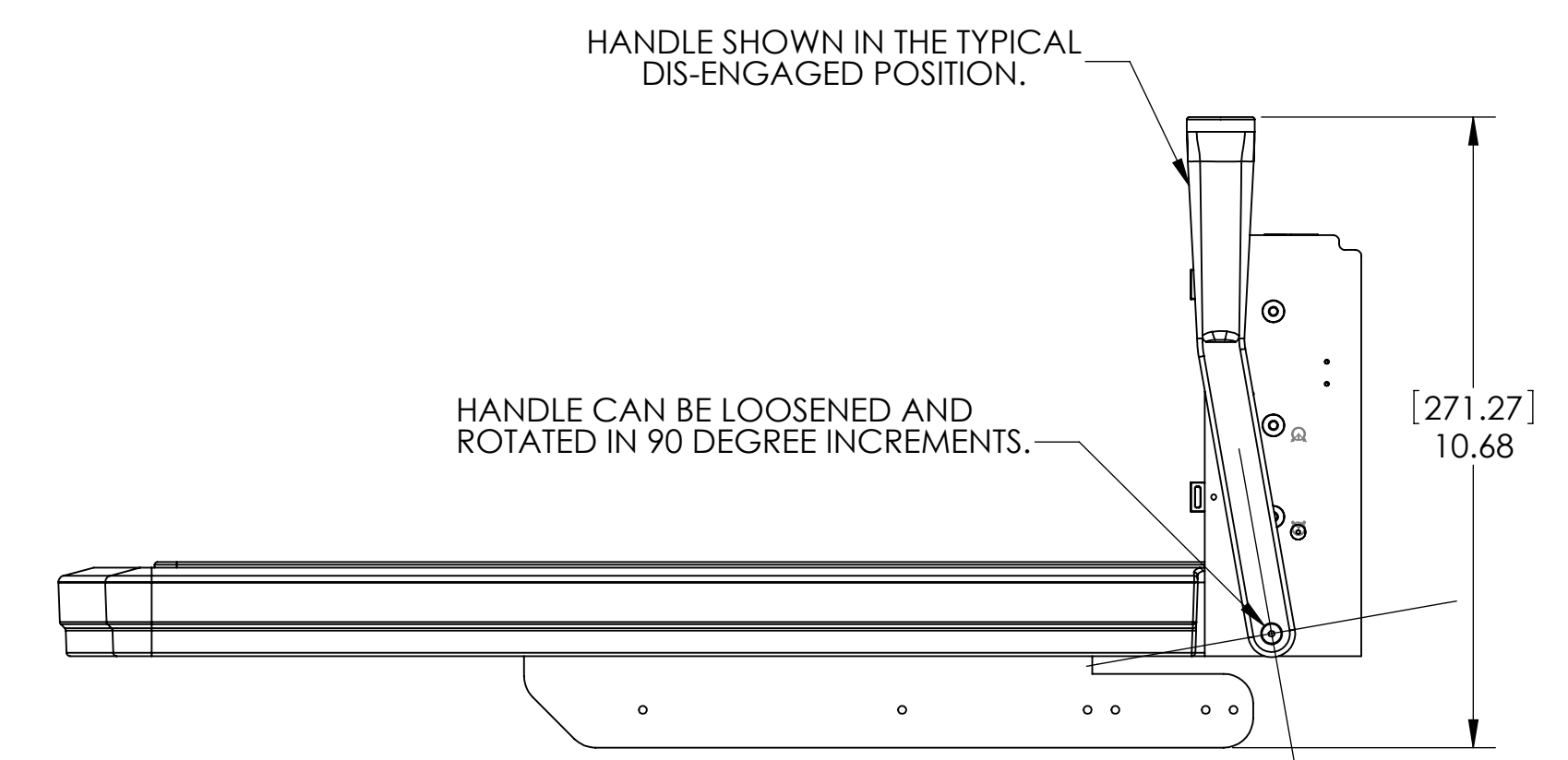
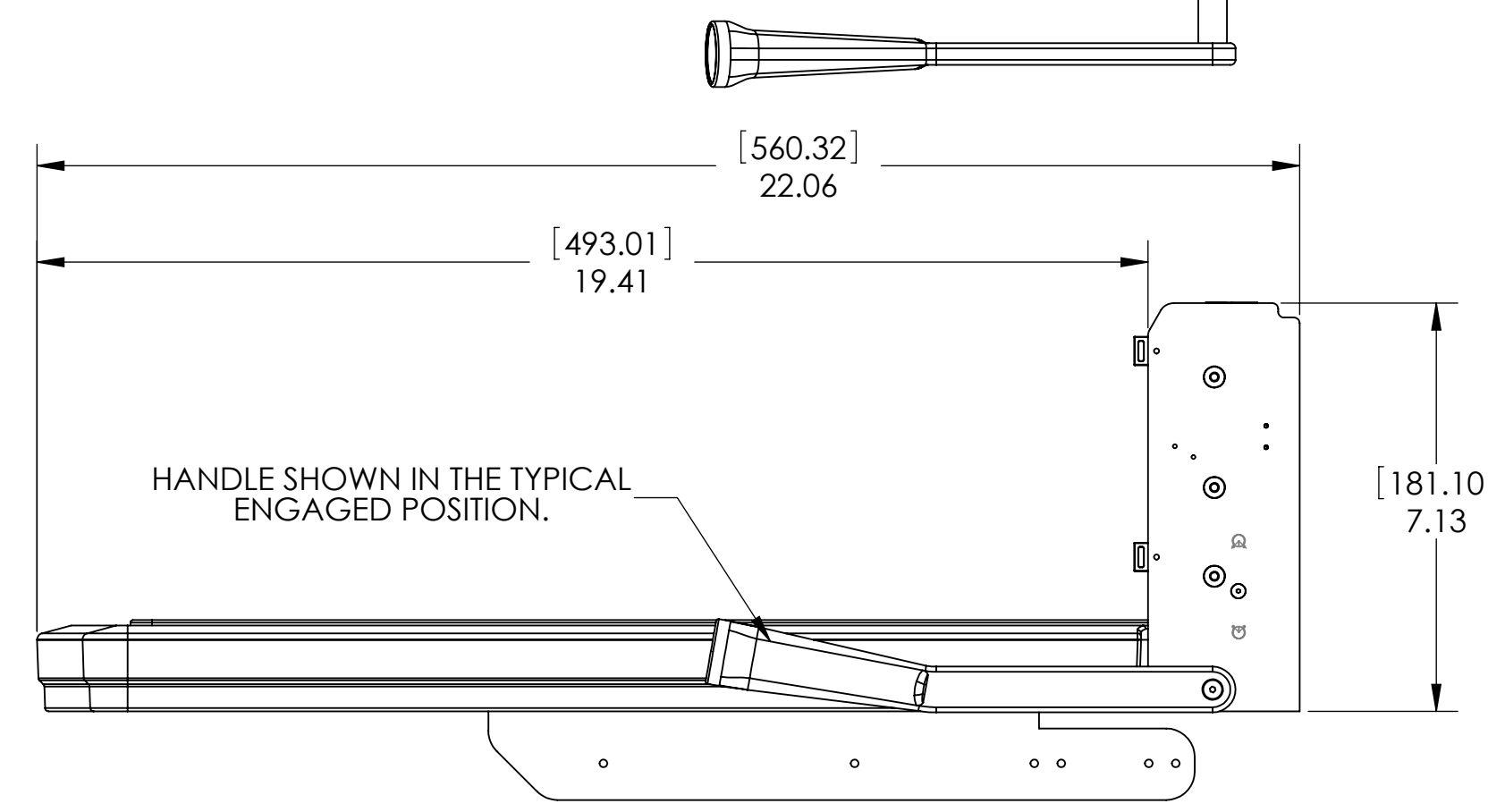

KEYING PLUG LOCATIONS							
PATTERN 1				PATTERN 4			
RECEIVER		ITA		RECEIVER		ITA	
PIN A INSTALLED	PIN C INSTALLED	SCREW A OPEN	SCREW C OPEN	PIN A INSTALLED	PIN C OPEN	SCREW A INSTALLED	SCREW C INSTALLED
PIN B OPEN	PIN D OPEN	SCREW B INSTALLED	SCREW D INSTALLED	PIN B INSTALLED	PIN D INSTALLED	SCREW B OPEN	SCREW D OPEN

PATTERN 2				PATTERN 5			
RECEIVER		ITA		RECEIVER		ITA	
PIN A INSTALLED	PIN C OPEN	SCREW A OPEN	SCREW C INSTALLED	PIN A OPEN	PIN C INSTALLED	SCREW A INSTALLED	SCREW C OPEN
PIN B INSTALLED	PIN D OPEN	SCREW B OPEN	SCREW D INSTALLED	PIN B INSTALLED	PIN D OPEN	SCREW B OPEN	SCREW D INSTALLED

PATTERN 3				PATTERN 6			
RECEIVER		ITA		RECEIVER		ITA	
PIN A OPEN	PIN C INSTALLED	SCREW A INSTALLED	SCREW C OPEN	PIN A INSTALLED	PIN C OPEN	SCREW A OPEN	SCREW C INSTALLED
PIN B OPEN	PIN D INSTALLED	SCREW B INSTALLED	SCREW D OPEN	PIN B OPEN	PIN D INSTALLED	SCREW B INSTALLED	SCREW D OPEN

MATING ITA	PROTECTIVE COVER	RACK EXTENDER FOR EURO RACKS
410104322 (12 MODULE)	310113518	310113519
410104474 (18 MODULE)		

IF KEYING IS REQUIRED USE VPC KEYING KIT PART NUMBER 310118112. SEE TABLE FOR KEYING OPTIONS.

- 6. (1) 3/32" ALLEN WRENCH INCLUDED FOR MODULE MOUNTING.
- 5. PLATFORM MAY BE SECURED TO A TABLE WITH 1/4-20 SCREWS.
- 4. WEIGHT: APPROXIMATELY 28 POUNDS, ALUMINUM AND STEEL.
- 3. FOR RACK MOUNT APPLICATIONS, A SLIDE KIT IS REQUIRED:
(2) 10-32 CAP SCREWS ARE INCLUDED TO SECURE RECEIVER TO RACK WHEN NOT IN USE.
- 2. MICROSWITCH WIRES NOT SHOWN. COLOR CODE AS FOLLOWS:
RED - NORMALLY CLOSED
WHITE - NORMALLY OPEN
BLACK - COMMON
- 1. FOR APPLICATION USE AND CARE INFORMATION CONSULT VPC USERS GUIDE @ WWW.VPC.COM

NOTES:

CUSTOMER DRAWING
VIRGINIA PANEL CORPORATION
 WWW.VPC.COM

RCV, G12X, SLIDE MOUNT
 EXTND SHFT, W/ 20" PLATFORM

DIMENSIONS ARE SHOWN AS:	SIZE	CAGE CODE	DWG. NO.	REV
[MILLIMETERS]	D	18117	310104457	B
[INCHES]	SCALE: 1:3	310104457	5/28/19	SHEET 1 OF 1