

4

3

2

1

DO NOT SCALE DRAWING

THE INFORMATION CONTAINED HEREIN IS THE EXCLUSIVE PROPERTY OF VIRGINIA PANEL CORP. AND IS SUBMITTED FOR USE BY THE CUSTOMER ONLY. THE DATA SHALL NOT BE DUPLICATED, USED, OR DISCLOSED IN WHOLE OR IN PART FOR ANY PURPOSE OTHER THAN TO MAINTAIN THE EQUIPMENT PROVIDED. CONSULT WITH VIRGINIA PANEL CORPORATION ENGINEERING IF MORE DETAIL IS REQUIRED.

REVISIONS				
ZONE	REV	DESCRIPTION	DATE	APPROVED
	A	ORIGINAL RELEASE	2/24/03	

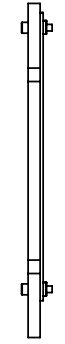
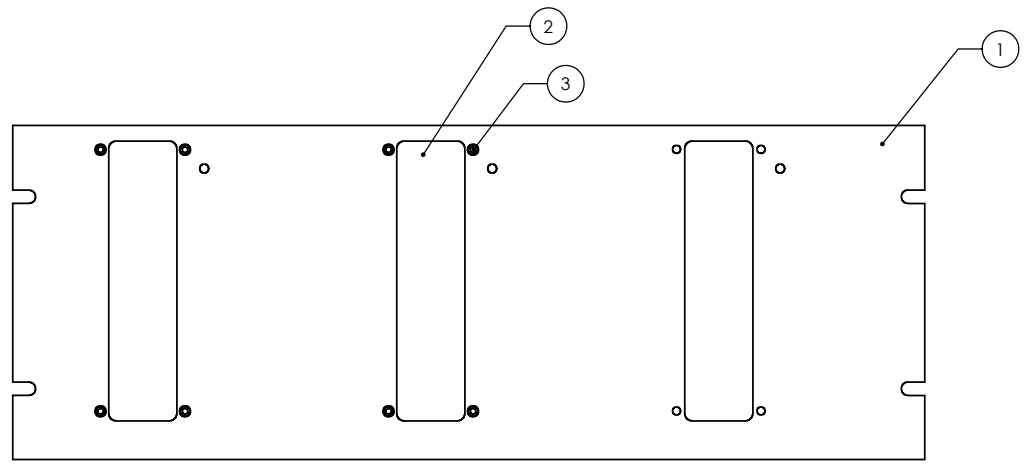

D  
C  
B  
A

D  
C  
B  
A

ITEM NO.	QTY.	PART NO.	DESCRIPTION
1	1	440820101	MOUNTING PLATE BLANK 5U
2	2	441204134	COVER PLATE 2102 GEMINI
3	8	900101	Scr Sh Cp 6-32 x .50 Blk

**CUSTOMER DRAWING - CUSTOMER DRAWING**

SOLIDWORKS DRAWING FILE	DIMENSIONS ARE SHOWN AS: (millimeters) INCHES		SIGNATURES		DATE	<b>VIRGINIA PANEL CORPORATION</b> WWW.VPC.COM		
			DR	REH	2/24/03			
	REMOVE BURRS, BREAK SHARP EDGES		CHK			PLATE, 2102 W/ 3 SLOTS		
	MATERIAL		ENG					
	FINISH		PROD					
		ASSY			SIZE	FSCM.NO.	DWG.NO.	REV
		Q A			C	18117	310113395	A
		APPD			SCALE: NONE	2/24/03	310113395	SHEET 1 OF 1

1 FOR APPLICATION, USE & CARE INFORMATION  
CONSULT VPC USERS GUIDE @WWW.VPC.COM

NOTES:

4

3

2

1