

4

3

2

1

DO NOT SCALE DRAWING

THE INFORMATION CONTAINED HEREIN IS THE EXCLUSIVE PROPERTY OF VIRGINIA PANEL CORP. AND IS SUBMITTED FOR USE BY THE CUSTOMER ONLY. THE DATA SHALL NOT BE DUPLICATED, USED, OR DISCLOSED IN WHOLE OR IN PART FOR ANY PURPOSE OTHER THAN TO MAINTAIN THE EQUIPMENT PROVIDED. CONSULT WITH VIRGINIA PANEL CORPORATION ENGINEERING IF MORE DETAIL IS REQUIRED.

REVISIONS

ZONE	REV	DESCRIPTION	DATE	APPROVED
	A	ORIGINAL RELEASE - ECN #05-310-0031	5/4/2005	
	B	ECN #05-310-0062	7/28/05	RLH
	C	ECN #05-310-0088	10/11/05	RLH

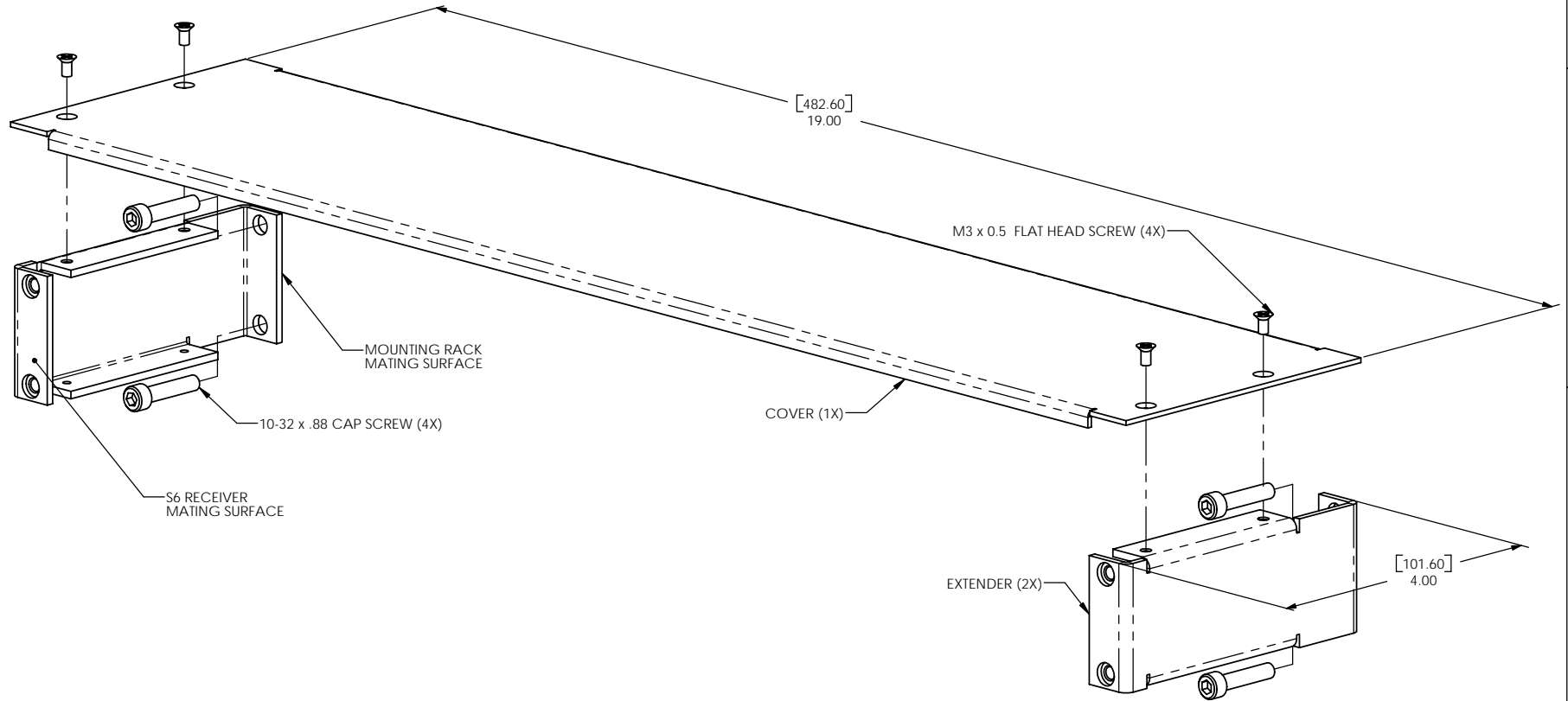

4. FOR USE WITH RECEIVER 310122100 AND 310122101, WHEN THE RAILS ARE RECESSED MORE THAN 1" FROM THE FRONT OF THE RACK

3. CAGE NUTS ARE NOT INCLUDED. M5 OR M6 SCREWS AND CAGE NUTS MAY BE SUBSTITUTED FOR 10-32 HARDWARE

2. RECOMMENDATIONS FOR ASSEMBLY

- A. INSTALL EXTENDERS TO RACK IN DESIRED LOCATION AS SHOWN USING 10-32 SCREWS (FINGER TIGHTEN ONLY)
- B. INSTALL S6 RECEIVER TO EXTENDERS USING MOUNTING HARDWARE SUPPLIED WITH S6 RECEIVER (FULLY TIGHTEN SCREWS)
- C. RETURN TO 10-32 SCREWS AND FULLY TIGHTEN EXTENDERS TO RACK
- D. INSTALL COVER USING M3 FLAT HEAD SCREWS

1. FOR APPLICATION, USE & CARE INFORMATION CONSULT VPC USERS GUIDE @WWW.VPC.COM

NOTES:

CUSTOMER DRAWING - CUSTOMER DRAWING

SOLIDWORKS DRAWING FILE	DIMENSIONS ARE SHOWN AS:	SIGNATURES	DATE	VIRGINIA PANEL CORPORATION WWW.VPC.COM			
	[millimeters] [INCHES]	DR CHK	R HERRON 5/4/2005				
	REMOVE BURRS. BREAK SHARP EDGES	ENG		RACK EXTENDER KIT, S6			
	MATERIAL	PROD					
FINISH	ASSY			SIZE C	CAGE CODE 18117	DWG.NO. 310113430	REV C
	APPD			SCALE: NONE	5/4/2005	310113430	SHEET 1 OF 1

4

3

2

1