

DO NOT SCALE DRAWING

THE INFORMATION CONTAINED HEREIN IS THE EXCLUSIVE PROPERTY OF VIRGINIA PANEL CORPORATION AND IS SUBMITTED FOR USE BY THE CUSTOMER ONLY. THE DATA SHALL NOT BE DUPLICATED, USED, OR DISCLOSED IN WHOLE OR IN PART FOR ANY PURPOSE OTHER THAN TO MAINTAIN THE EQUIPMENT PROVIDED. CONSULT WITH VIRGINIA PANEL CORPORATION ENGINEERING IF MORE DETAIL IS REQUIRED.

REVISIONS

REV	DESCRIPTION	DATE	ENGR
D	ECN# 5490	9/16/14	J SHAND

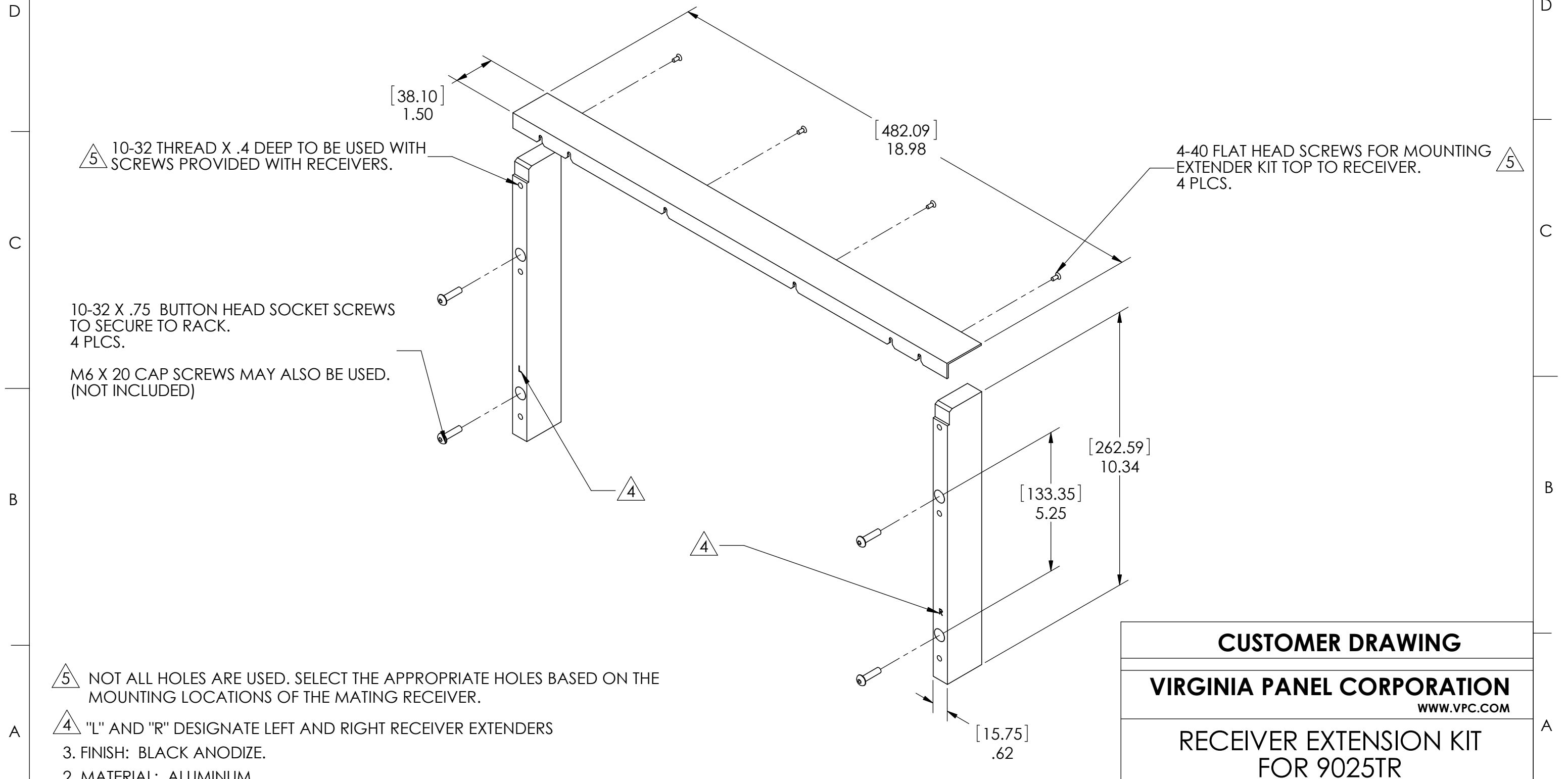

5 10-32 THREAD X .4 DEEP TO BE USED WITH SCREWS PROVIDED WITH RECEIVERS.

10-32 X .75 BUTTON HEAD SOCKET SCREWS TO SECURE TO RACK. 4 PLCS.

M6 X 20 CAP SCREWS MAY ALSO BE USED. (NOT INCLUDED)

4-40 FLAT HEAD SCREWS FOR MOUNTING EXTENDER KIT TOP TO RECEIVER. 4 PLCS. 5

5 NOT ALL HOLES ARE USED. SELECT THE APPROPRIATE HOLES BASED ON THE MOUNTING LOCATIONS OF THE MATING RECEIVER.

4 "L" AND "R" DESIGNATE LEFT AND RIGHT RECEIVER EXTENDERS

3. FINISH: BLACK ANODIZE.

2. MATERIAL: ALUMINUM.

1. FOR APPLICATION USE AND CARE INFORMATION CONSULT VPC USERS GUIDE @ WWW.VPC.COM

NOTES:

CUSTOMER DRAWING

VIRGINIA PANEL CORPORATION

WWW.VPC.COM

RECEIVER EXTENSION KIT FOR 9025TR

DIMENSIONS ARE SHOWN AS:

[MILLIMETERS]  
INCHES

SIZE	CAGE CODE	DWG.NO.	REV
B	18117	310113494	D
SCALE: NONE		310113494 02/05/2008	SHEET 1 OF 1