

4

3

2

1

DO NOT SCALE DRAWING

THE INFORMATION CONTAINED HEREIN IS THE EXCLUSIVE PROPERTY OF VIRGINIA PANEL CORPORATION AND IS SUBMITTED FOR USE BY THE CUSTOMER ONLY. THE DATA SHALL NOT BE DUPLICATED, USED, OR DISCLOSED IN WHOLE OR IN PART FOR ANY PURPOSE OTHER THAN TO MAINTAIN THE EQUIPMENT PROVIDED. CONSULT WITH VIRGINIA PANEL CORPORATION ENGINEERING IF MORE DETAIL IS REQUIRED.

REVISIONS			
REV	DESCRIPTION	DATE	ENGR
A	DRAWING ORIGINATION - ECN #13939	1/15/24	R HERRON

D

D

C

C

B

B

A

A

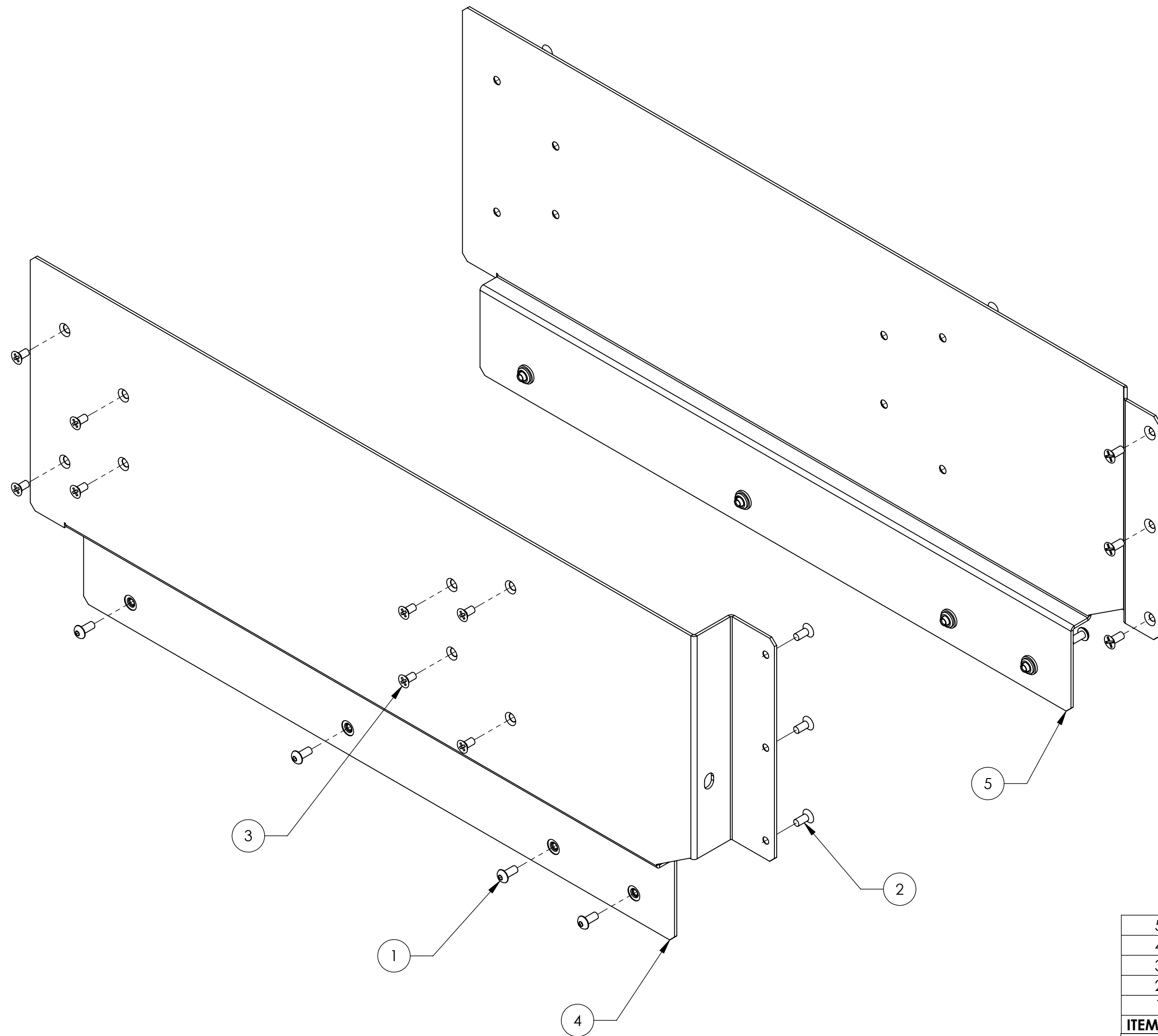

ITEM NO.	QTY.	DESCRIPTION
5	1	ADPTR FLNG G40X EMI RCV, RT
4	1	ADPTR FLNG G40X EMI RCV, LF
3	6	SCR FH PHL 8-32 x .38 SST 100 DEG
2	16	SCR FH PHL M4 x 8MM
1	8	SCR BH SOC #8-32 x .38 BLK

CUSTOMER DRAWING

VIRGINIA PANEL CORPORATION
WWW.VPC.COM

CHASSIS FLANGE MOUNT KIT
G40X EMI RCV TO NI PXI 1045

DIMENSIONS ARE SHOWN AS:	SIZE	CAGE CODE	DWG. NO.	REV
[MILLIMETERS]	C	18117	310113797	A
INCHES	SCALE: 1:2	310113797	1/15/24	SHEET 1 OF 1

2. HARDWARE REQUIRED TO MOUNT FLANGES TO THE RECEIVER, SLIDE KIT AND CHASSIS ALL INCLUDED WITH THIS ASSEMBLY.

1. FOR APPLICATION USE & CARE INFORMATION CONSULT VPC USERS GUIDE @WWW.VPC.COM

NOTES:

4

3

2

1