

4

3

2

1

DO NOT SCALE DRAWING

THE INFORMATION CONTAINED HEREIN IS THE EXCLUSIVE PROPERTY OF VPC AND IS PERMITTED FOR USE BY THE CUSTOMER ONLY. THE DATA SHALL NOT BE DUPLICATED, USED, OR DISCLOSED IN WHOLE OR IN PART FOR ANY PURPOSE OTHER THAN TO MAINTAIN THE EQUIPMENT PROVIDED. CONSULT WITH VPC ENGINEERING IF MORE DETAIL IS REQUIRED.

REVISIONS

REV	DESCRIPTION	DATE	ENGR
B	ECN #15364	11/5/2025	M ECKERT

D

D

C

C

B

B

A

A

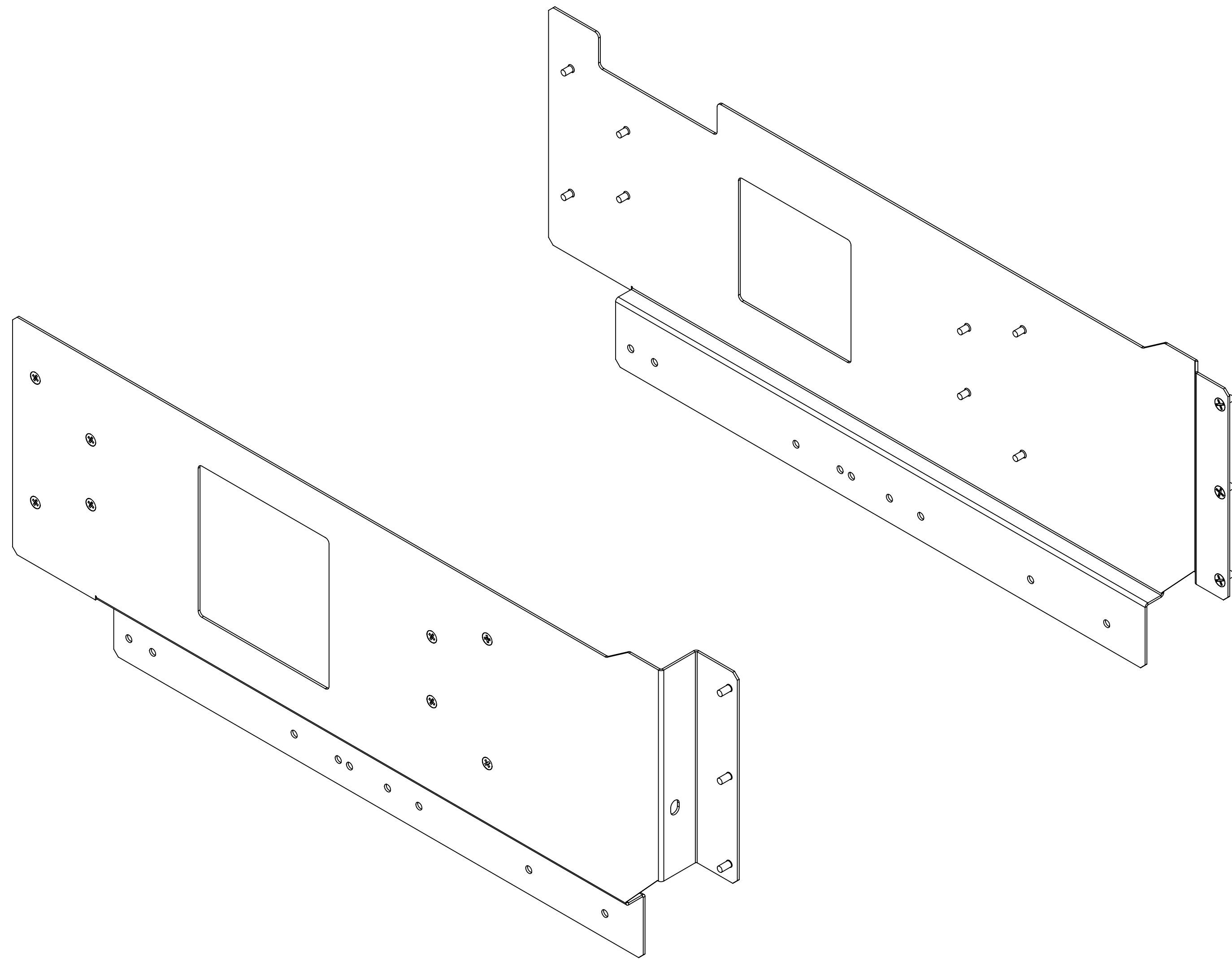

NOTES:  
 2. SEE HARDWARE LISTING FOR SIZES AND LOCATIONS.  
 1. FOR MORE INFORMATION, VISIT VPC.COM.

INCLUDED HARDWARE	QTY	PURPOSE
SCR FH PHL M4 X 8MM	16	ATTACHES FLANGES TO PXI CHASSIS
SCR FH PHL 8-32 .375 100D	6	ATTACHES FLANGES TO THE RECIEVER
SCR PH PHL 8-32 .375	8	ATTACHES FLANGES TO RACK SLIDES
WSH LK #8	8	ATTACHES FLANGES TO RACK SLIDES
NUT HEX #8	8	ATTACHES FLANGES TO RACK SLIDES

DIMENSIONS ARE SHOWN AS:  
 [MILLIMETERS]  
 INCHES

<b>CUSTOMER DRAWING</b>			
<b>VIRGINIA PANEL CORPORATION</b> WWW.VPC.COM			
RCV FLNG KT G40X EMI 1084/95			
SIZE	CAGE CODE	DWG. NO.	REV
C	18117	310113802	B
SCALE: NONE			SHEET 1 OF 1

4

3

2

1