

THE INFORMATION CONTAINED HEREIN IS THE EXCLUSIVE PROPERTY OF VPC AND IS PERMITTED FOR USE BY THE CUSTOMER ONLY. THE DATA SHALL NOT BE DUPLICATED, USED, OR DISCLOSED IN WHOLE OR IN PART FOR ANY PURPOSE OTHER THAN TO MAINTAIN THE EQUIPMENT PROVIDED. CONSULT WITH VPC ENGINEERING IF MORE DETAIL IS REQUIRED.

REVISIONS			
REV	DESCRIPTION	DATE	ENGR
F	ECN #14238	5/31/24	M SALE

DO NOT SCALE DRAWING

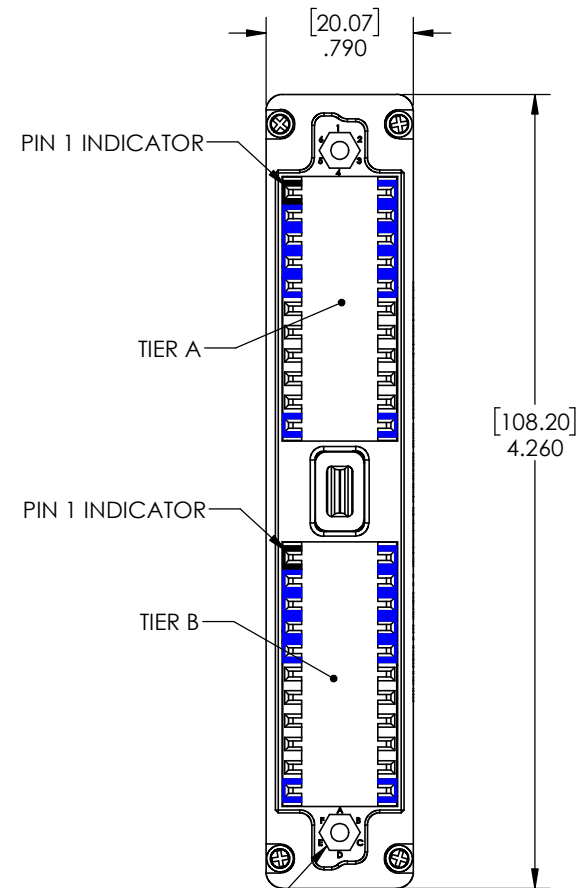
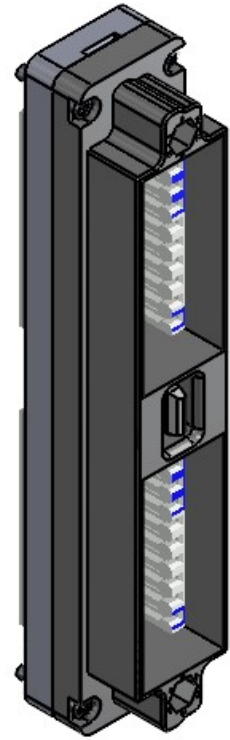

CAVITY FOR KEYING KIT, TYP. 2 PLCS. ACCESSORY P/N 310113461 [2 KEYS PER KIT] NOT INCLUDED WITH RECEIVER

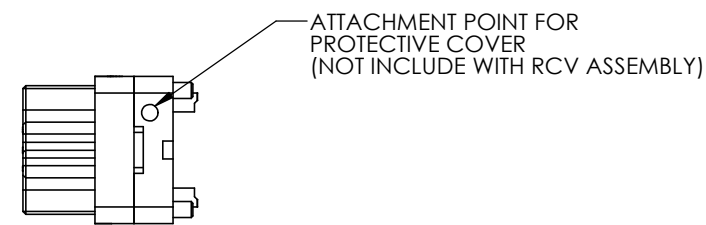
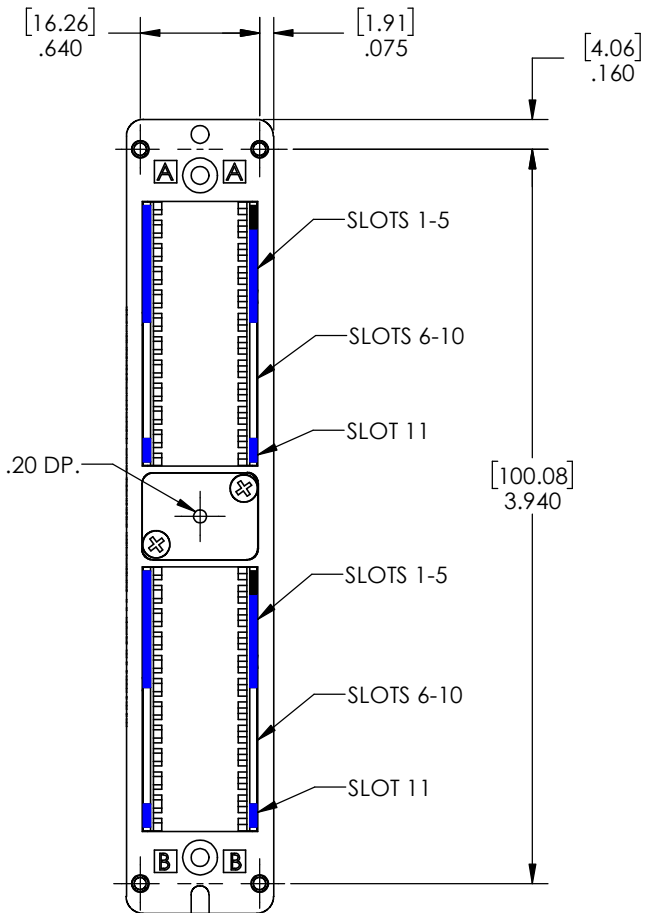
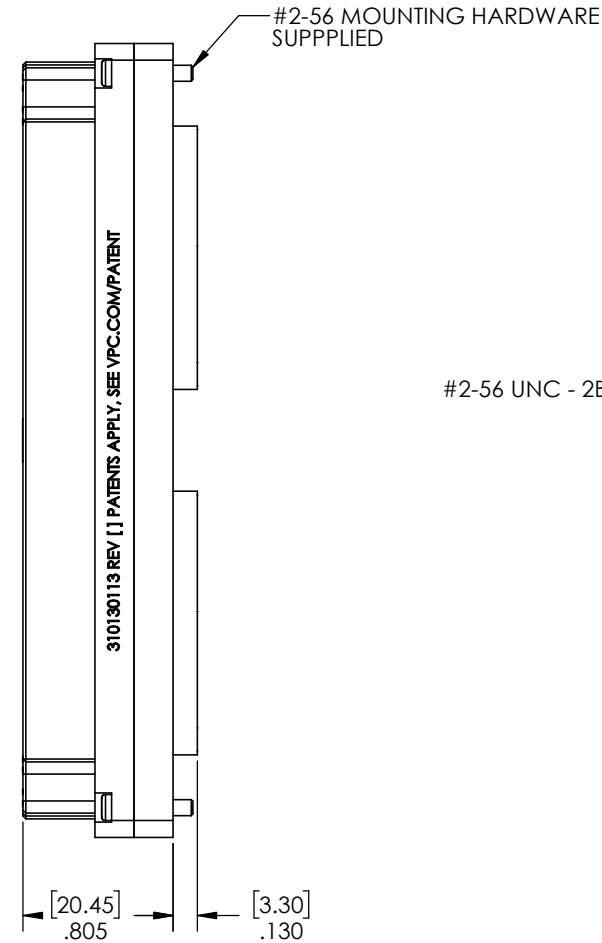

2. MATERIALS:
 FRAME & INSERTS: NI PLATED ZINC
 ALL HARDWARE: STAINLESS STEEL
 1. FOR MORE INFORMATION, VISIT VPC.COM.
 NOTES:

CUSTOMER DRAWING			
VIRGINIA PANEL CORPORATION WWW.VPC.COM			
12 MX RCV ASSEMBLY HIGH SPEED EMI			
DIMENSIONS ARE SHOWN AS:	SIZE	CAGE CODE	DWG. NO.
[MILLIMETERS]	C	18117	310130113
INCHES			
SCALE: NONE	310130113	8/1/14	SHEET 1 OF 2

D
C
B
A

D
C
B
A

4

3

2

1

4

3

2

1

