

8 7 6 5 4 3 2 1

DO NOT SCALE DRAWING

THE INFORMATION CONTAINED HEREIN IS THE EXCLUSIVE PROPERTY OF VIRGINIA PANEL CORPORATION AND IS SUBMITTED FOR USE BY THE CUSTOMER ONLY. THE DATA SHALL NOT BE DUPLICATED, USED OR DISCLOSED IN WHOLE OR IN PART FOR ANY PURPOSE OTHER THAN TO MAINTAIN THE EQUIPMENT PROVIDED. CONSULT WITH VIRGINIA PANEL CORPORATION ENGINEERING IF MORE DETAIL IS REQUIRED.

REVISIONS			
REV	DESCRIPTION	DATE	ENGR
B	ECN #9214	6/28/19	R GARMAN

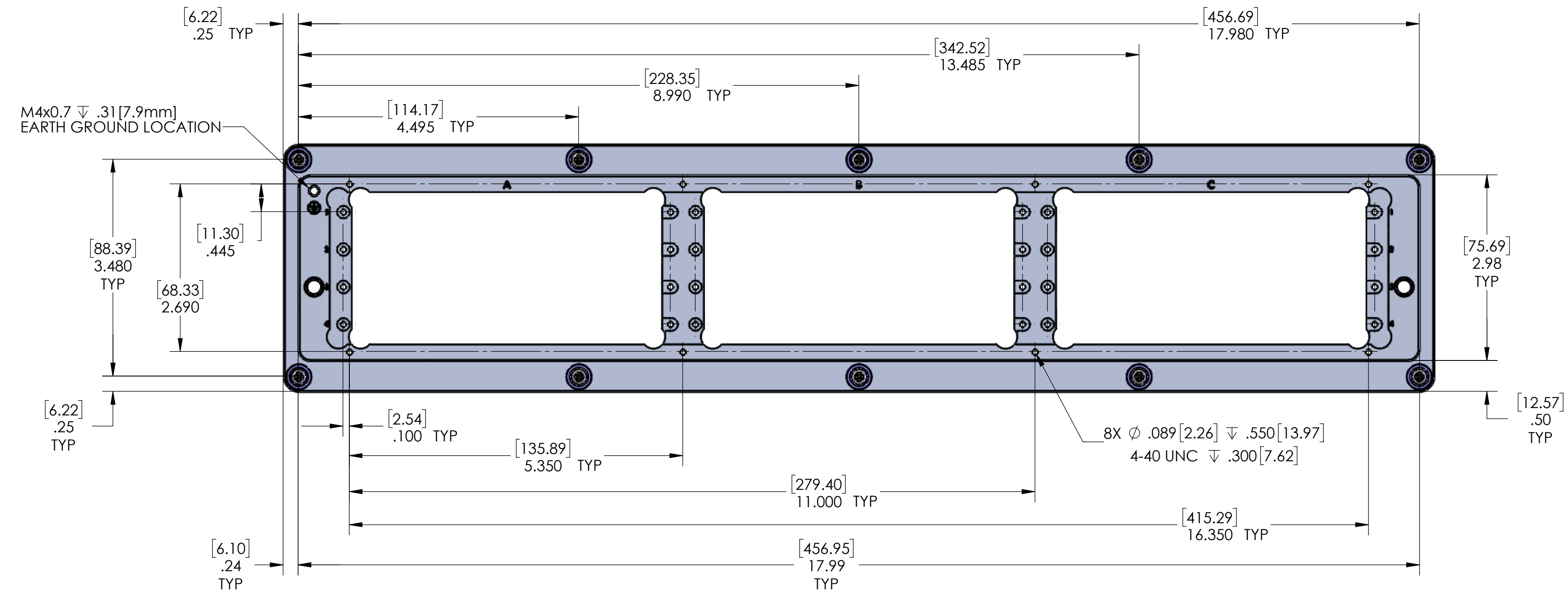
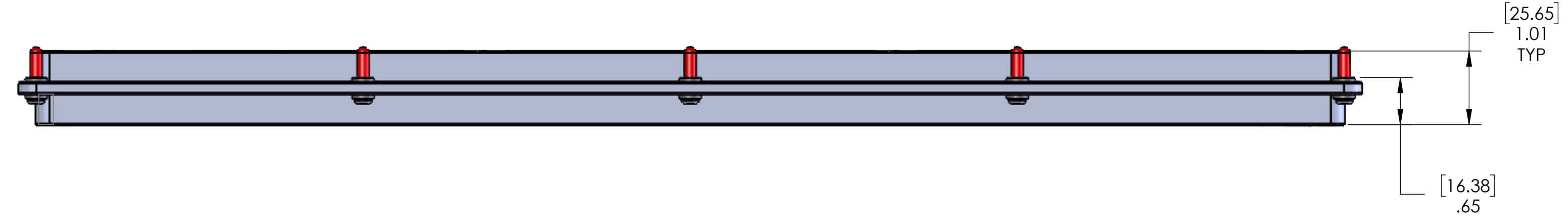
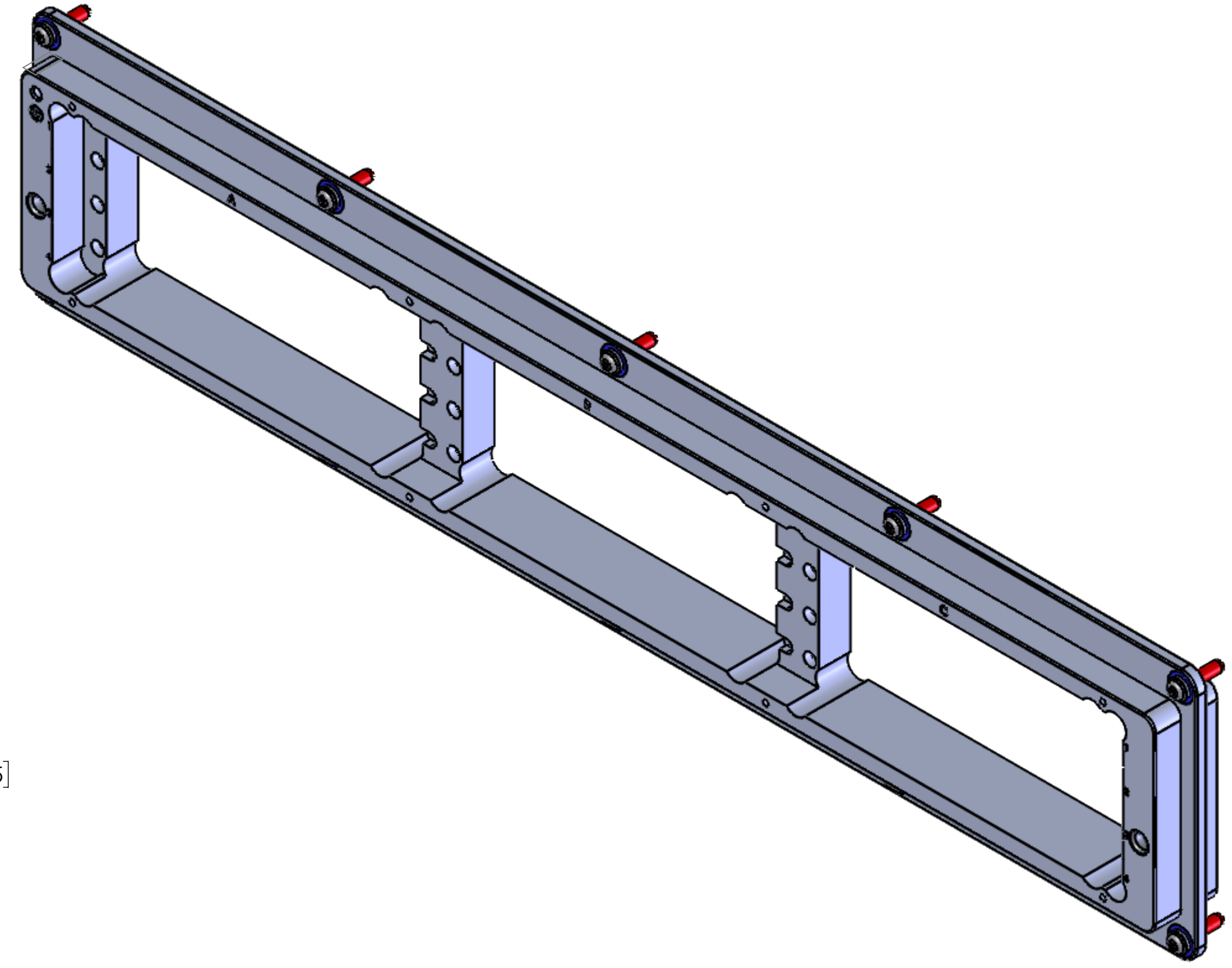
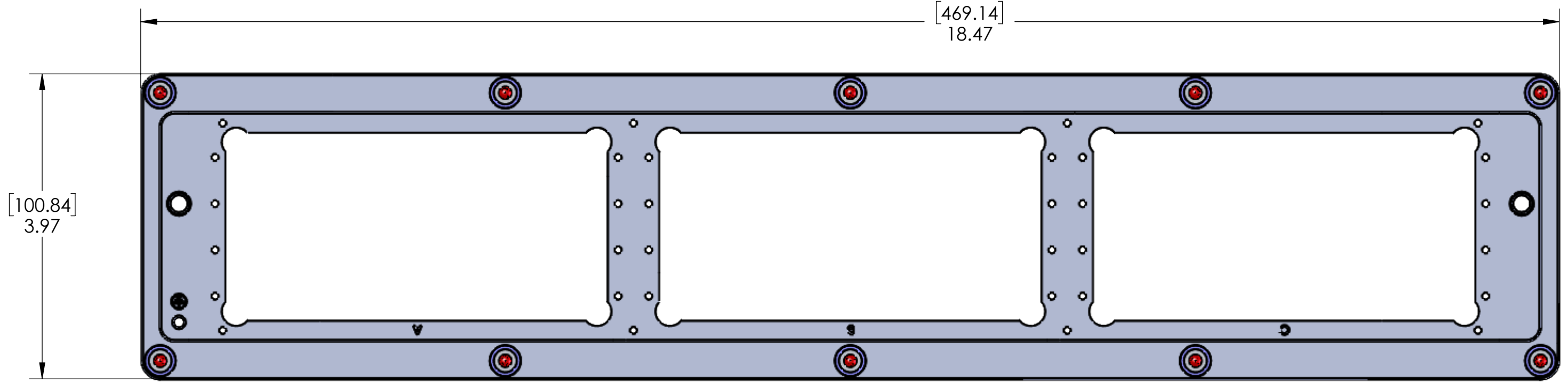

3. MATERIALS AND FINISHES
 FRAME - ALUMINUM, NICKEL PLATED
 ALIGNMENT PINS - STAINLESS STEEL, PASSIVATED
 MOUNTING HARDWARE - STAINLESS STEEL, PASSIVATED

2. PRODUCT WEIGHT - 1.85 LBS [0.84 KG]

1. FOR APPLICATION USE AND CARE INFORMATION CONSULT VPC USERS GUIDE @ WWW.VPC.COM

NOTES:

8 7 6 5 4 3 2 1

CUSTOMER DRAWING			
VIRGINIA PANEL CORPORATION WWW.VPC.COM			
D12 RCVR DOCKING CONNECTOR			
RELATIVE CONNECTOR POSITIONS AND WIRE ROUTING ARE GENERIC AND MAY VARY WITH PROFILE.	SIZE	CAGE CODE	DWG. NO.
DIMENSIONS ARE SHOWN AS:	D	18117	310131103
[MILLIMETERS]			
INCHES	SCALE: 3:4	310131103	12/1/17 SHEET 1 OF 2

DO NOT SCALE DRAWING

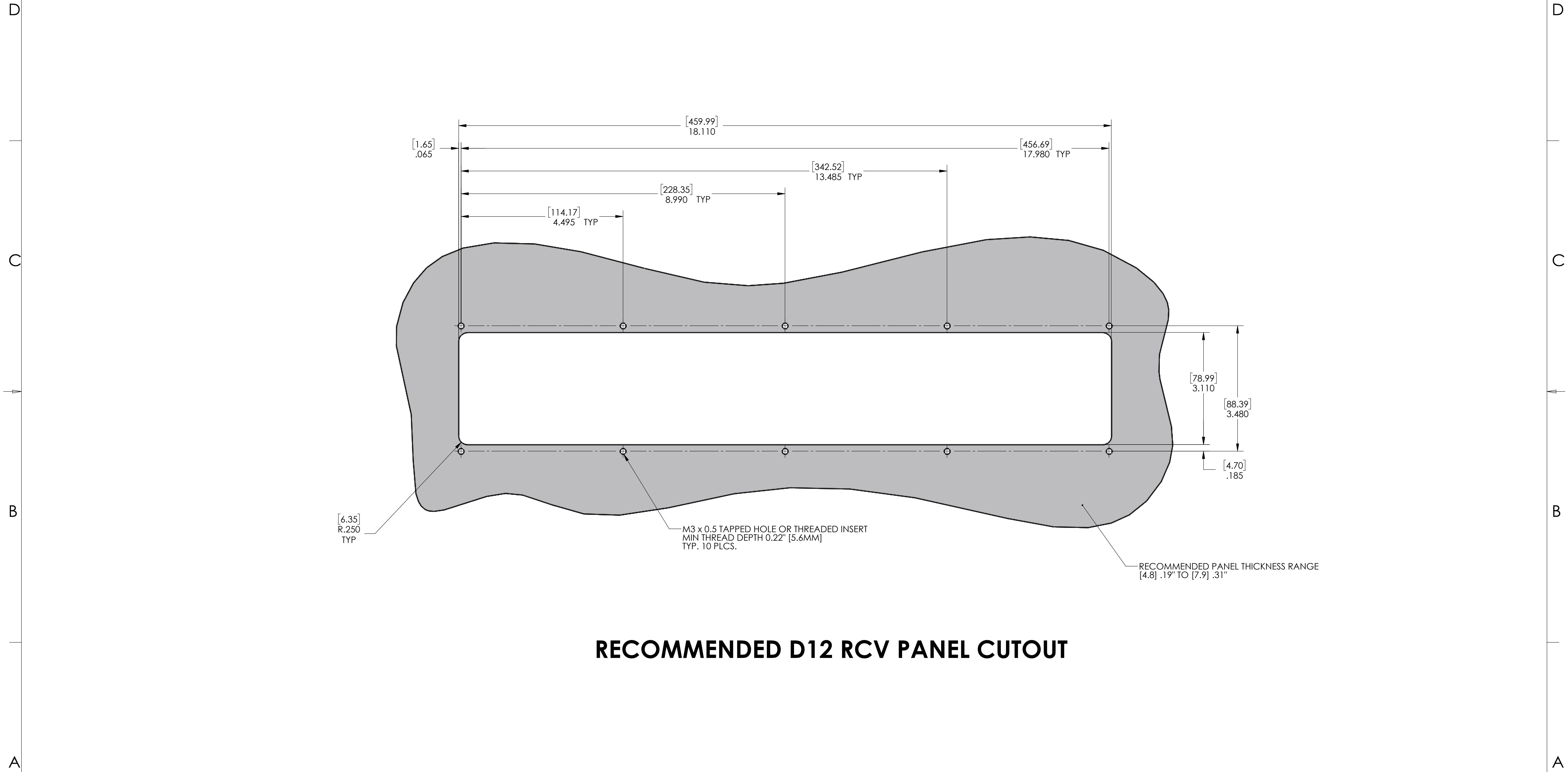

RECOMMENDED D12 RCV PANEL CUTOUT

NOTES:

CUSTOMER DRAWING			
DIMENSIONS ARE SHOWN AS:	SIZE	CAGE CODE	DWG. NO.
[MILLIMETERS]	D	18117	410131103
INCHES	SCALE: 3:4	310131103	SHEET 2 OF 2