

DO NOT SCALE DRAWING

THE INFORMATION CONTAINED HEREIN IS THE EXCLUSIVE PROPERTY OF VIRGINIA PANEL CORPORATION AND IS SUBMITTED FOR USE BY THE CUSTOMER ONLY. THE DATA SHALL NOT BE DUPLICATED, USED, OR DISCLOSED IN WHOLE OR IN PART FOR ANY PURPOSE OTHER THAN TO MAINTAIN THE EQUIPMENT PROVIDED. CONSULT WITH VIRGINIA PANEL CORPORATION ENGINEERING IF MORE DETAIL IS REQUIRED.

REVISIONS			
REV	DESCRIPTION	DATE	ENGR
H	ECN #9664	11/4/19	J HARDIGREE

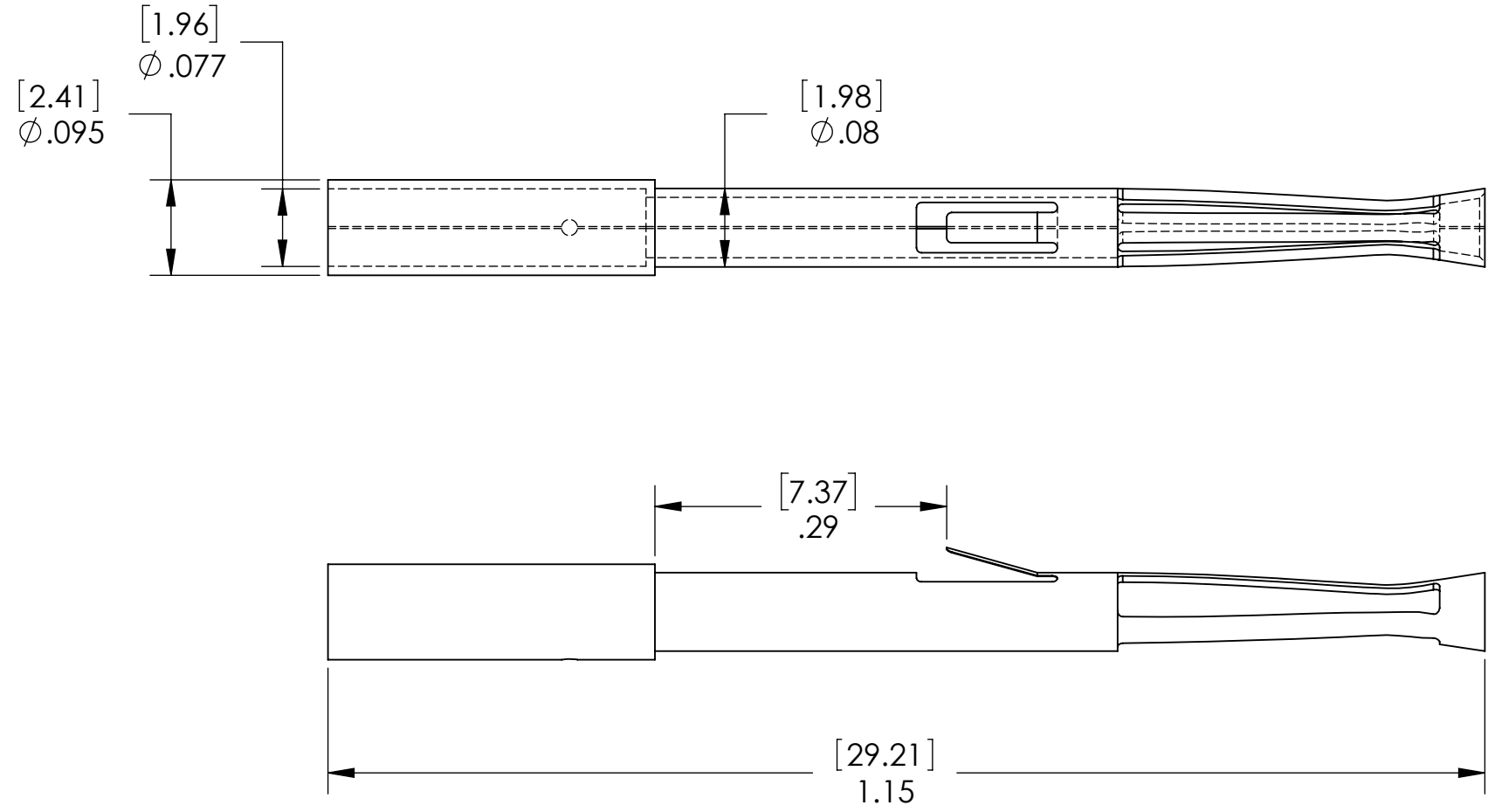

PART NUMBER	DESCRIPTION
610110177	TRIPADDLE FEMALE 30 μ " AU
610110128	TRIPADDLE FEMALE 50 μ " AU

2. PHYSICAL CHARACTERISTICS:
 WEIGHT - .00006 LBS
 MATERIAL - BeCu ALLOY
 PLATING - 30 μ " OR 50 μ " GOLD OVER 100 μ " NICKEL

1. FOR APPLICATION USE AND CARE INFORMATION CONSULT VPC USERS GUIDE @ WWW.VPC.COM

NOTES:

DIMENSIONS ARE SHOWN AS:
 [MILLIMETERS]
 INCHES

CUSTOMER DRAWING			
VIRGINIA PANEL CORPORATION WWW.VPC.COM			
TRIPADDLE, RECEIVER SOCKET, 14-18 AWG			
SIZE B	CAGE CODE 18117	DWG.NO. 344600102	REV H
SCALE: NONE	344600102	7/26/11	SHEET 1 OF 1