

4

3

2

1

DO NOT SCALE DRAWING

THE INFORMATION CONTAINED HEREIN IS THE EXCLUSIVE PROPERTY OF VIRGINIA PANEL CORPORATION AND IS SUBMITTED FOR USE BY THE CUSTOMER ONLY. THE DATA SHALL NOT BE DUPLICATED, USED, OR DISCLOSED IN WHOLE OR IN PART FOR ANY PURPOSE OTHER THAN TO MAINTAIN THE EQUIPMENT PROVIDED. CONSULT WITH VIRGINIA PANEL CORPORATION ENGINEERING IF MORE DETAIL IS REQUIRED.

| REVISIONS |             |        |            |
|-----------|-------------|--------|------------|
| REV       | DESCRIPTION | DATE   | ENGR       |
| J         | ECN #4243   | 9/4/12 | S MARSHALL |

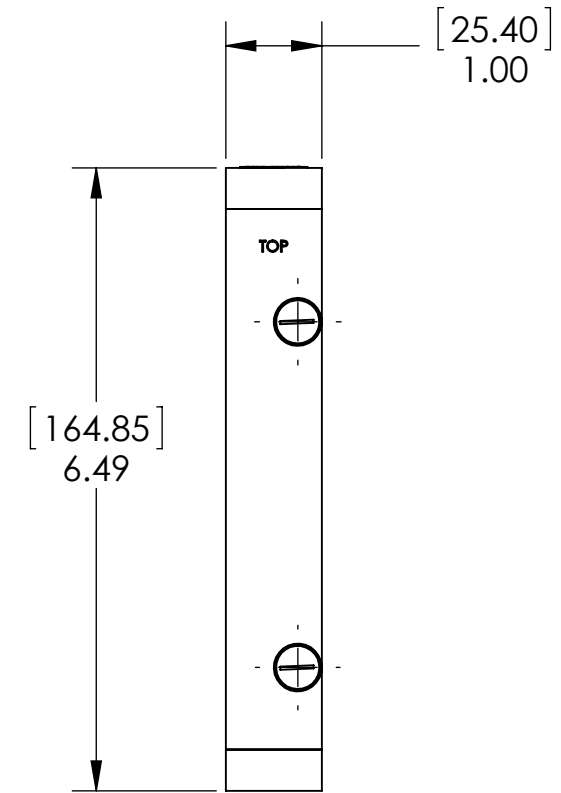
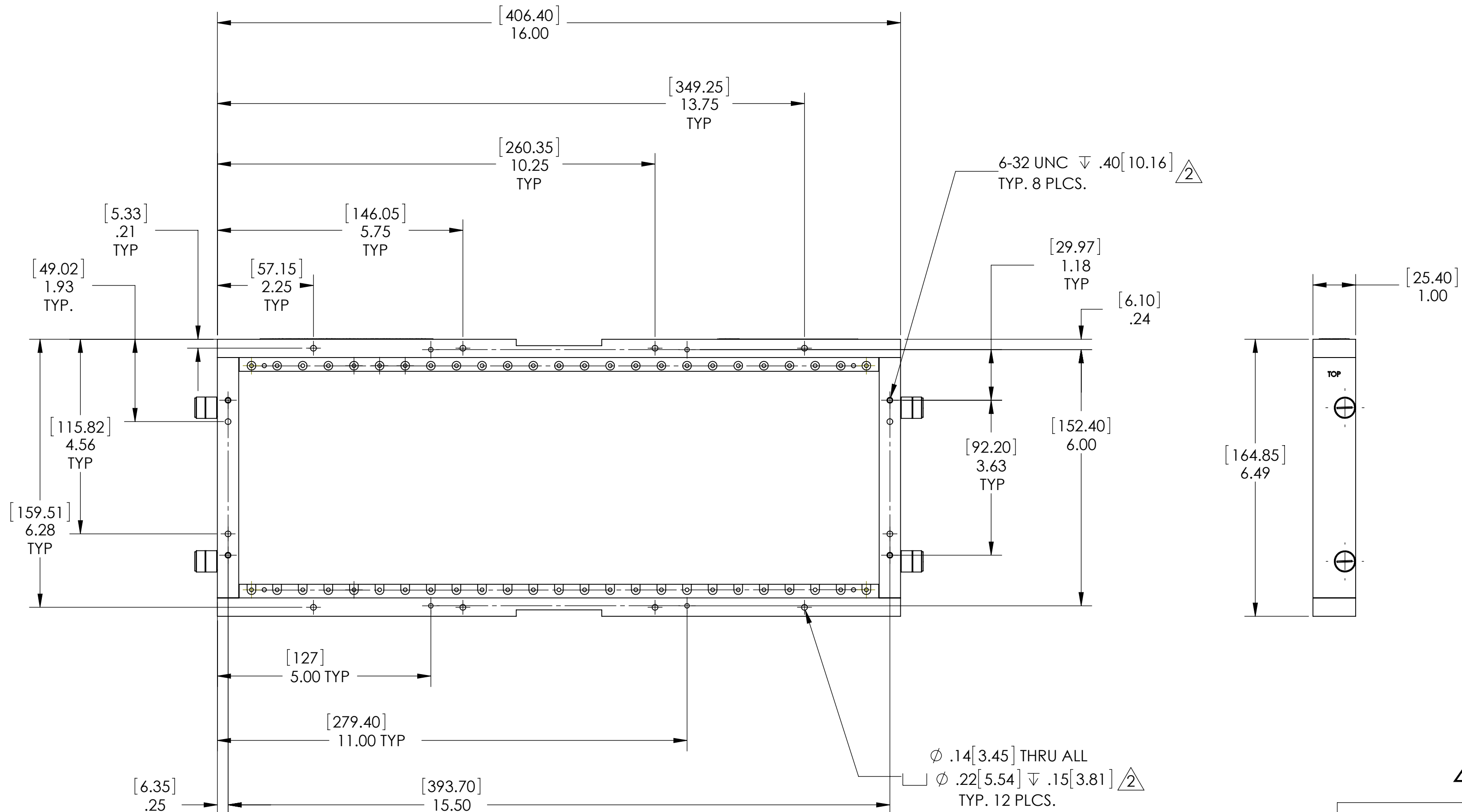

$\triangle$  (8) 6-32 TAPPED HOLES FOR USE WITH REAR MOUNT ENCLOSURES.  
 (12) 4-40 THROUGH HOLES FOR USE WITH FRONT MOUNT ENCLOSURES.  
 1. FOR APPLICATION USE & CARE INFORMATION CONSULT VPC USERS GUIDE @WWW.VPC.COM

|  |            |           |                       |
|--|------------|-----------|-----------------------|
| RELATIVE CONNECTOR POSITIONS AND WIRE ROUTING ARE GENERIC AND MAY VARY WITH PINOUT |            |           |                       |
| DIMENSIONS ARE SHOWN AS:   | SIZE       | CAGE CODE | DWG. NO.              |
| [MILLIMETERS]  | C          | 18117     | 3551 01 000           |
| INCHES   | SCALE: 1:2 | 355101000 | 10/19/93 SHEET 1 OF 1 |

410104111

**CUSTOMER DRAWING**

**VIRGINIA PANEL CORPORATION**  
WWW.VPC.COM

**25 MODULE ITA**

4

3

2

1