

4

3

2

1

DO NOT SCALE DRAWING

THE INFORMATION CONTAINED HEREIN IS THE EXCLUSIVE PROPERTY OF VIRGINIA PANEL CORPORATION AND IS SUBMITTED FOR USE BY THE CUSTOMER ONLY. THE DATA SHALL NOT BE DUPLICATED, USED, OR DISCLOSED IN WHOLE OR IN PART FOR ANY PURPOSE OTHER THAN TO MAINTAIN THE EQUIPMENT PROVIDED. CONSULT WITH VIRGINIA PANEL CORPORATION ENGINEERING IF MORE DETAIL IS REQUIRED.

REVISIONS			
REV	DESCRIPTION	DATE	ENGR
B	ECN #13331	4/5/23	R HERRON

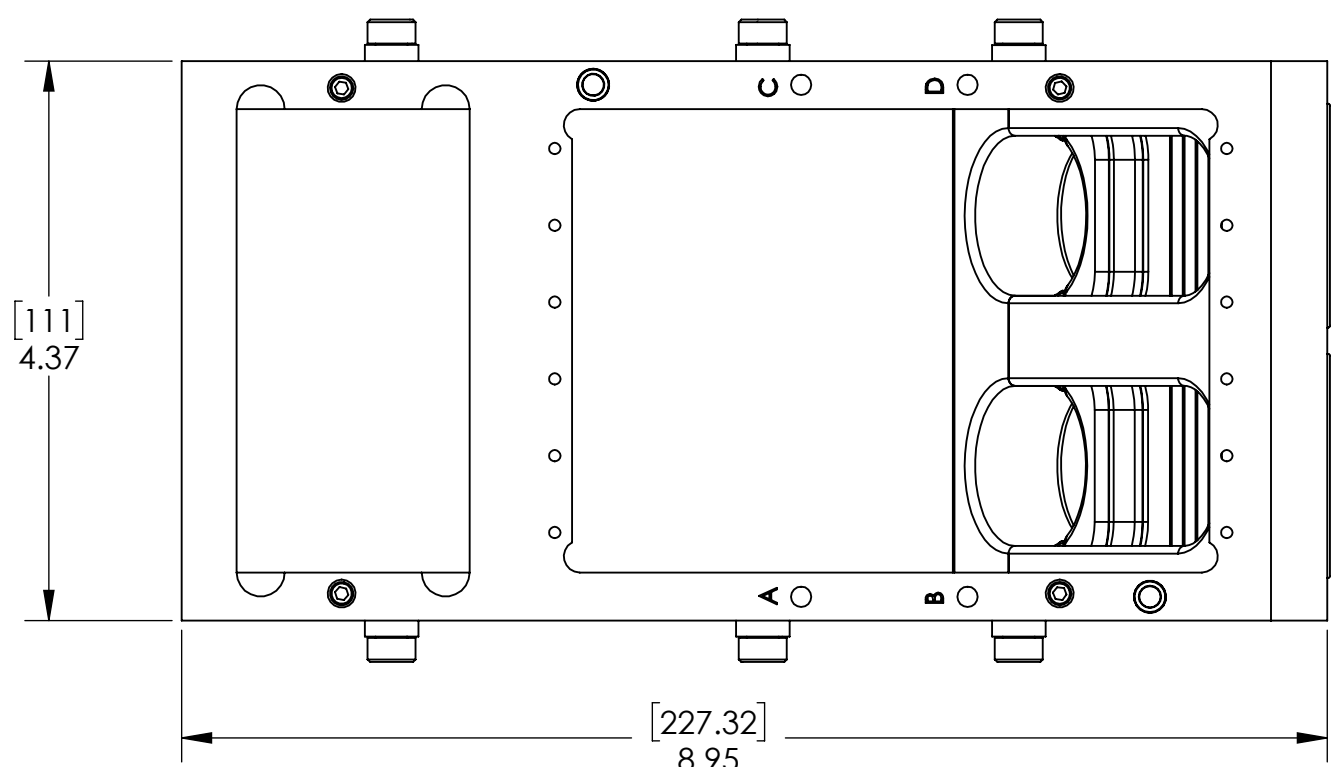
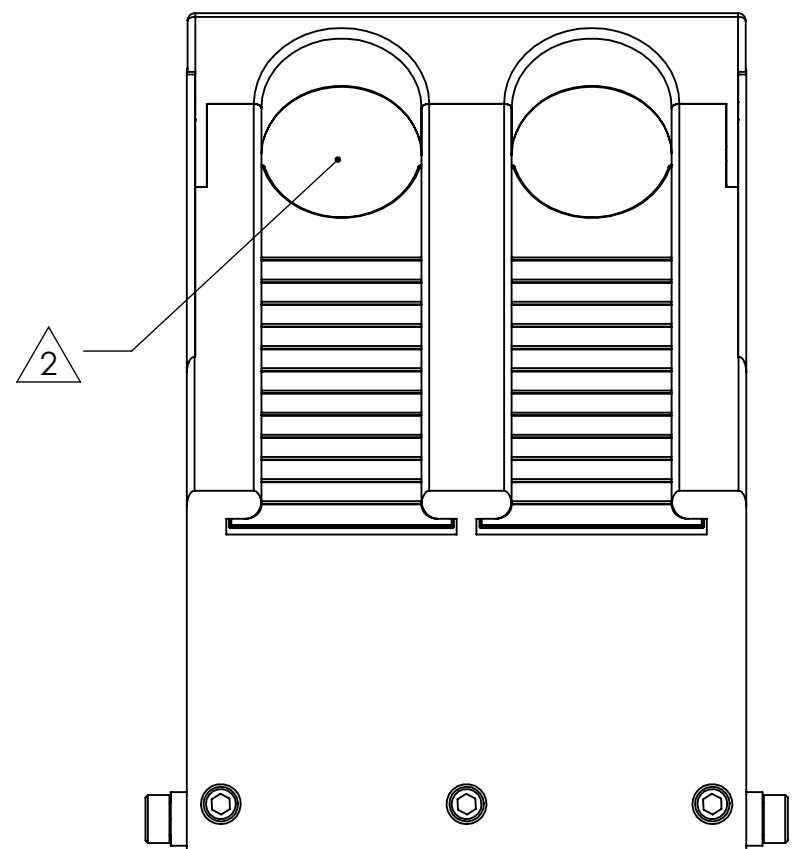
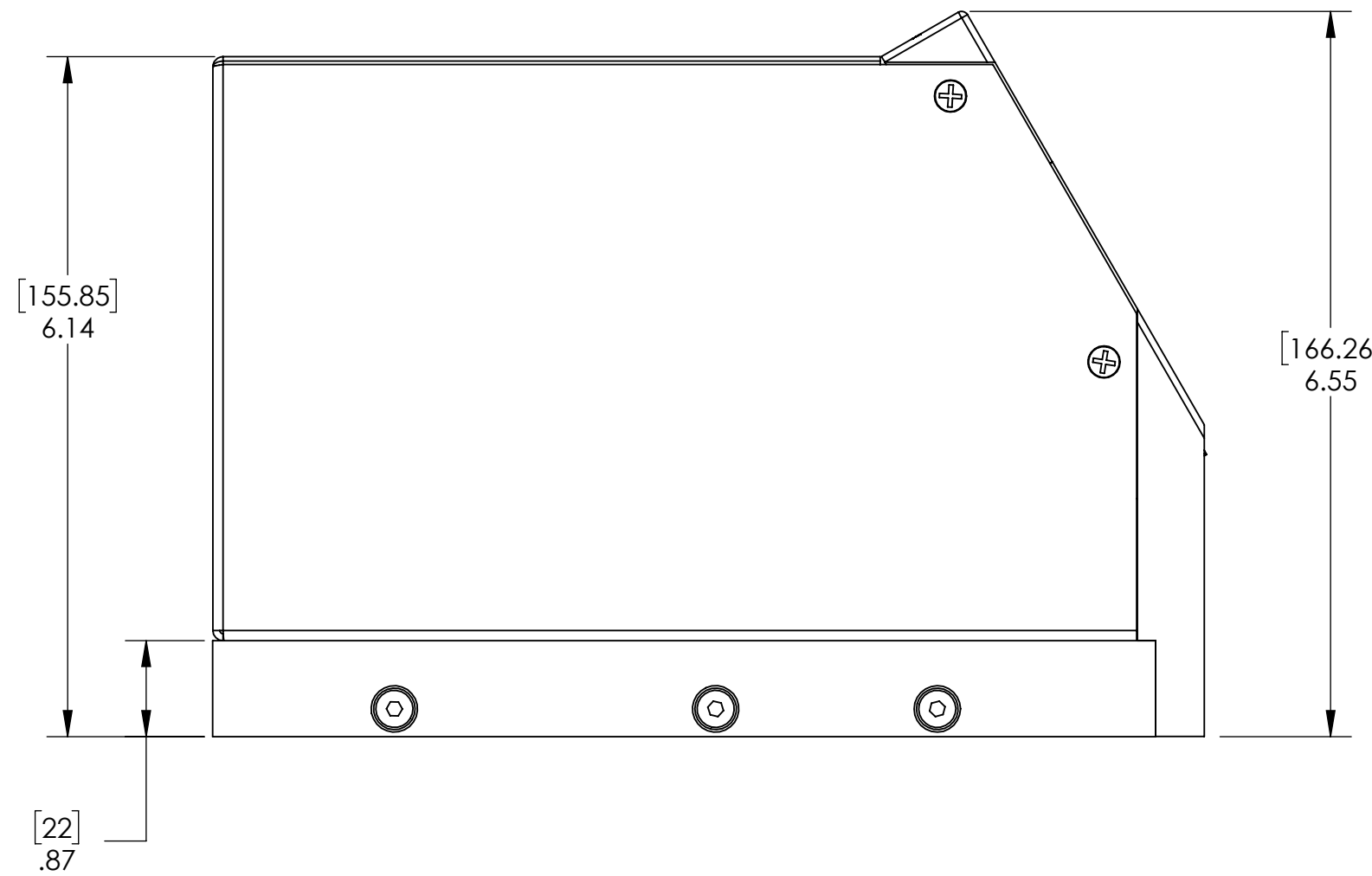
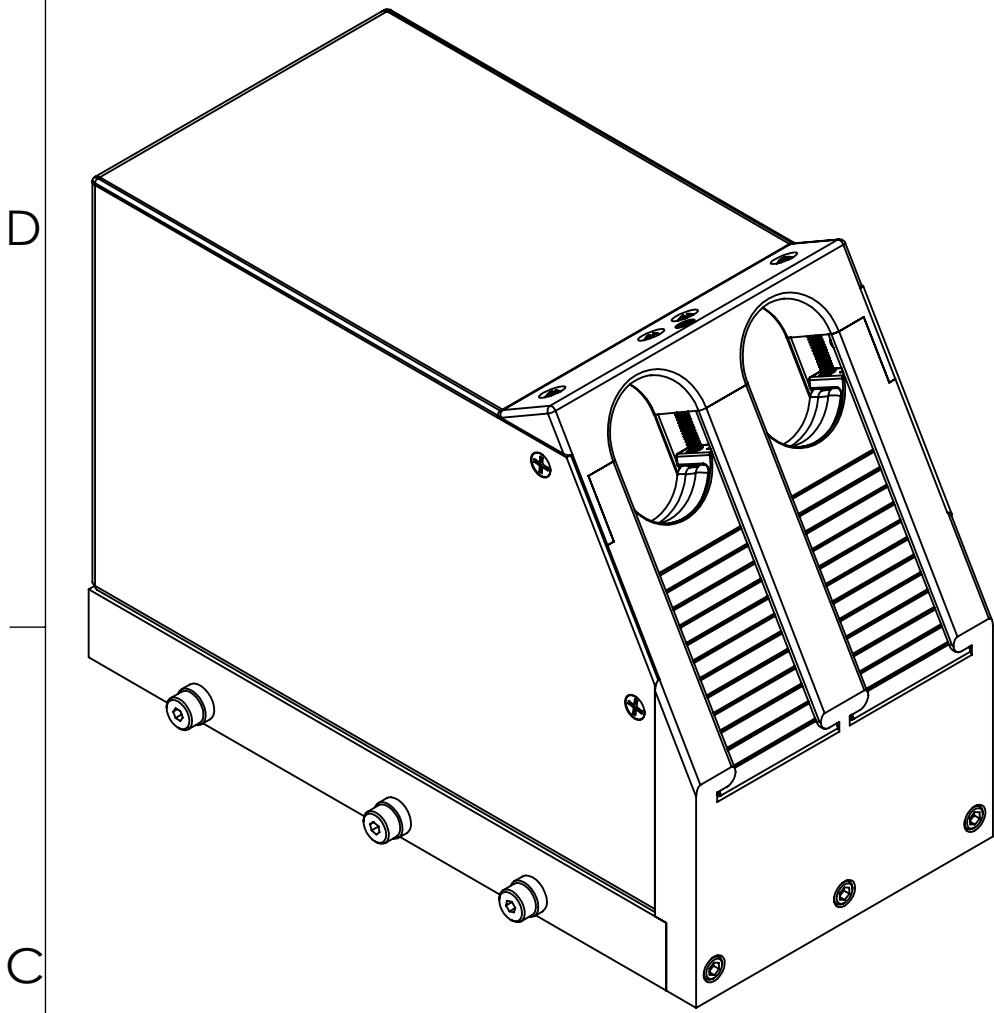

4. MATERIALS:
 FRAME COMPONENTS - ALUMINUM ALLOY, CHROMATED
 HOUSING & CABLE CLAMP - ALUMINUM ALLOY, POWDER COATED
 SHIELD - ABS PLASTIC
 CLAMP SCREWS - ZINC PLATED STEEL
 SOC HEAD CAP SCREWS - STAINLESS STEEL
 BEARINGS - ALLOY STEEL

3. MATING RCV P/N - 310104481

△ MAX CABLE BUNDLE EQUIVALENT TO 2.50". FOR SMALLER BUNDLES USE THE ADJUSTABLE SHIELD TO CLOSE OFF OPENING. EXCESS SHIELD MATERIAL MAY BE SNAPPED OFF AT BOTTOM OF OPENING

1. FOR APPLICATION USE & CARE INFORMATION CONSULT VPC USERS GUIDE @WWW.VPC.COM
 NOTES:

RELATIVE CONNECTOR POSITIONS AND WIRE ROUTING ARE GENERIC AND MAY VARY WITH PINOUT			
DIMENSIONS ARE SHOWN AS:	SIZE	CAGE CODE	DWG. NO.
[MILLIMETERS]	C	18117	410104769
INCHES			
SCALE: 2:3	410104769	1/4/2018	SHEET 1 OF 1

CUSTOMER DRAWING
VIRGINIA PANEL CORPORATION
 WWW.VPC.COM

ITA, G6X

4

3

2

1

A

B

C

D