

DO NOT SCALE DRAWING

THE INFORMATION CONTAINED HEREIN IS THE EXCLUSIVE PROPERTY OF VIRGINIA PANEL CORPORATION AND IS SUBMITTED FOR USE BY THE CUSTOMER ONLY. THE DATA SHALL NOT BE DUPLICATED, USED OR DISCLOSED IN WHOLE OR IN PART FOR ANY PURPOSE OTHER THAN TO MAINTAIN THE EQUIPMENT PROVIDED. CONSULT WITH VIRGINIA PANEL CORPORATION ENGINEERING IF MORE DETAIL IS REQUIRED.

REVISIONS			
REV	DESCRIPTION	DATE	ENGR
F	ECN #10536	8/6/20	J HARDIGREE

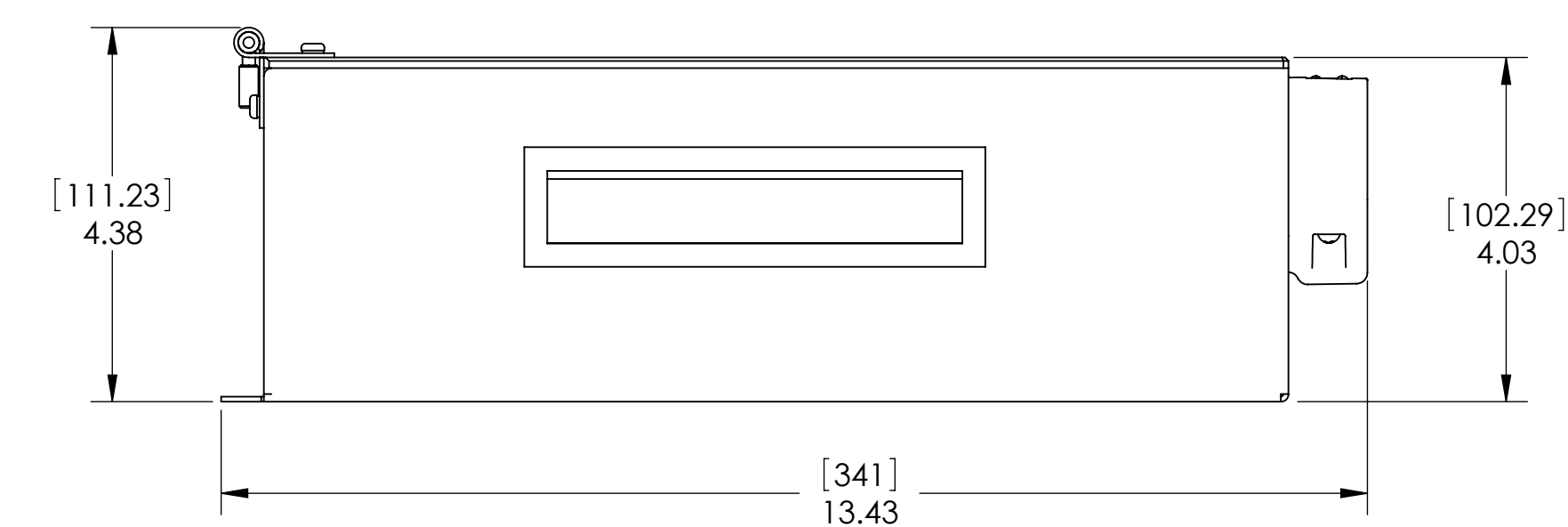
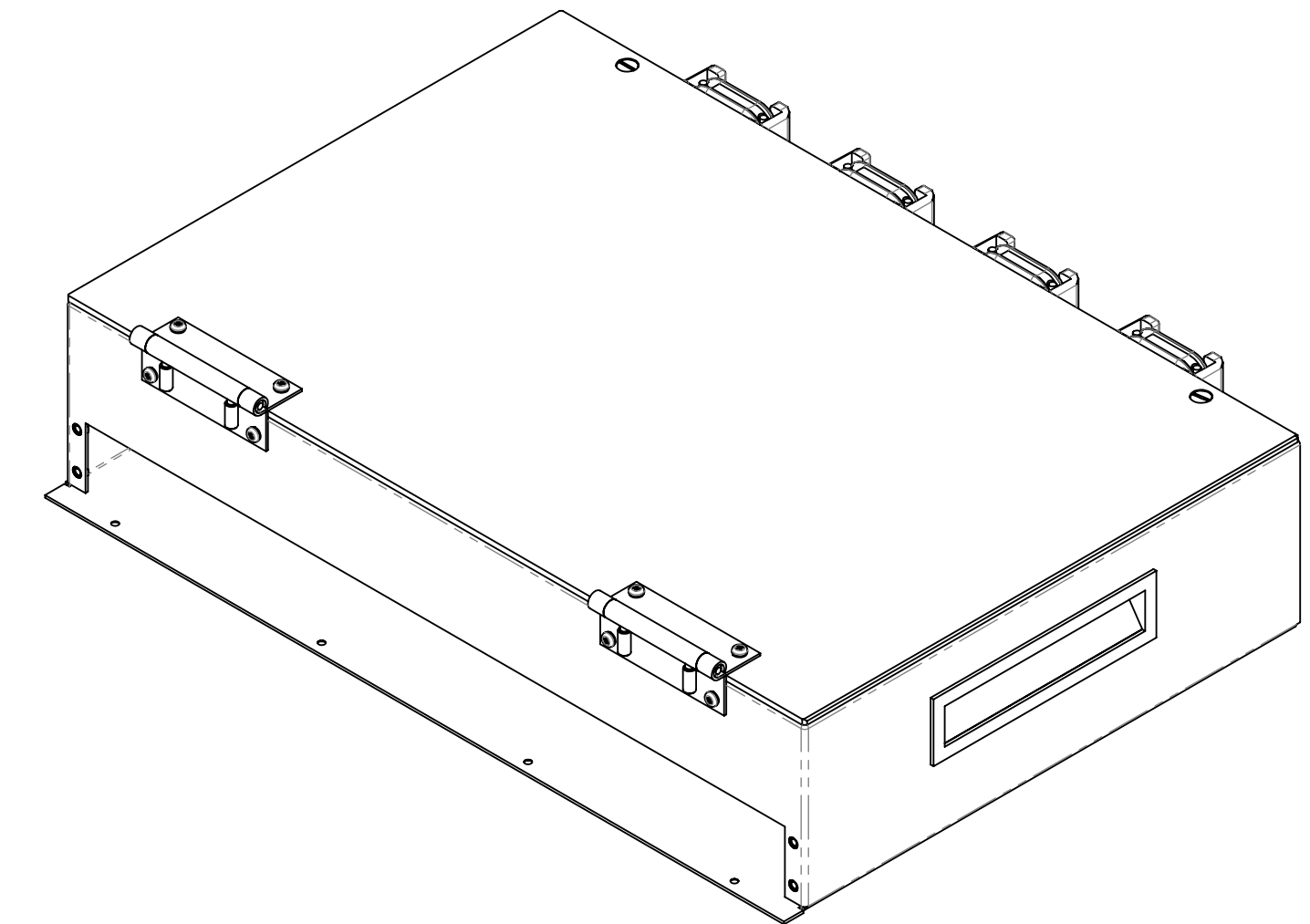
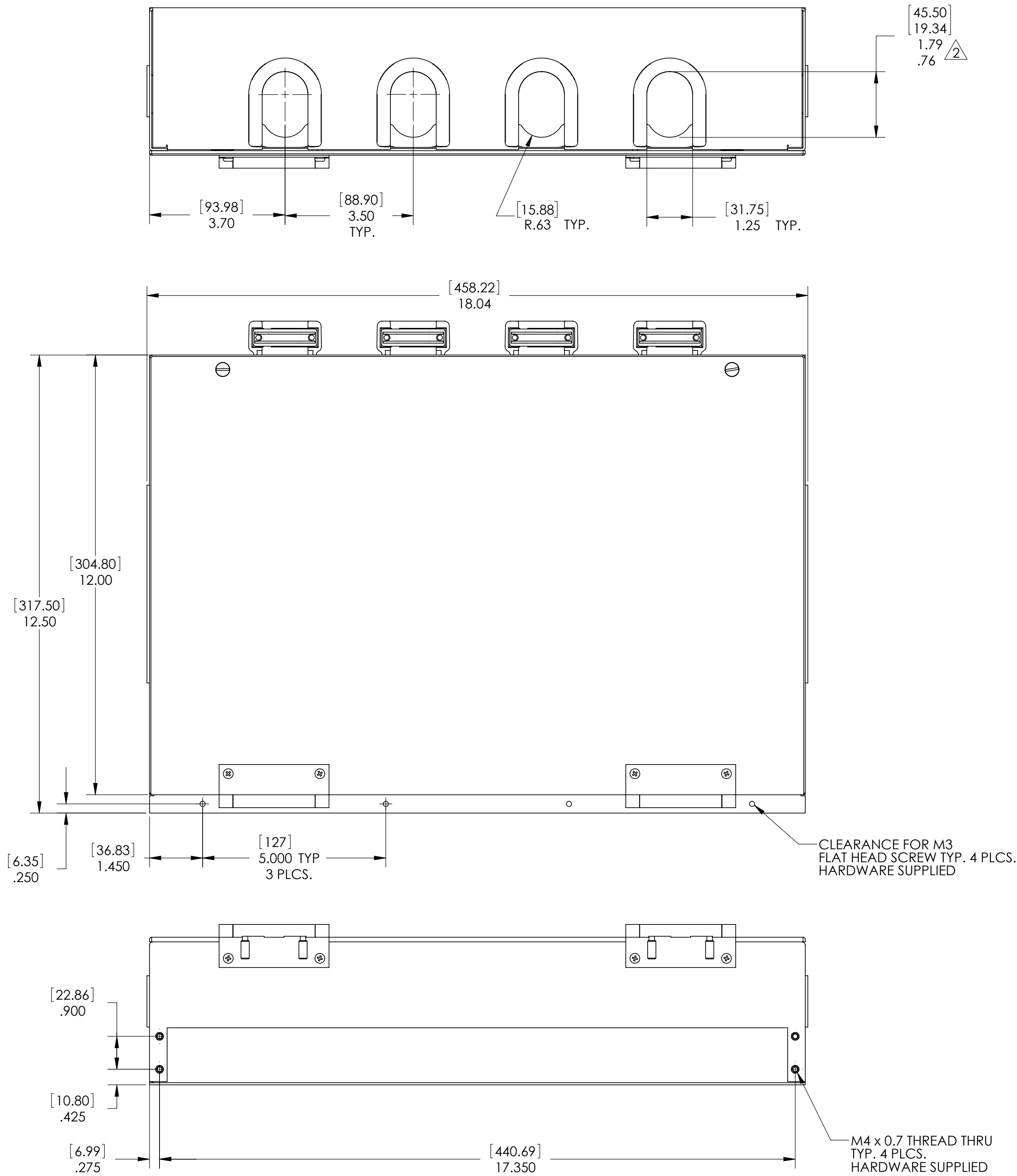

3. FOR USE WITH ITA 410122100  
 Δ FUNCTIONAL CLAMPING RANGE. FOR SMALLER WIRE BUNDLES CLAMP CAN BE INVERTED WITH FLAT SIDE TOWARD WIRES  
 1. FOR APPLICATION USE AND CARE INFORMATION CONSULT VPC USERS GUIDE @ WWW.VPC.COM

NOTES:

<b>CUSTOMER DRAWING</b>			
<b>VIRGINIA PANEL CORPORATION</b> WWW.VPC.COM			
<b>ENCLOSURE, S6</b> 4 x 12 x 18 FOR DISCRETE WIRING			
RELATIVE CONNECTOR POSITIONS AND WIRE ROUTING ARE GENERIC AND MAY VARY WITH PRODUCT.	SIZE	CAGE CODE	DWG. NO.
DIMENSIONS ARE SHOWN AS: [MILLIMETERS] INCHES	D	18117	410112712
SCALE: 1:2	410112712	8/16/2005	SHEET 1 OF 2

8 7 6 5 4 3 2 1

D

D

C

C

B

B

A

A

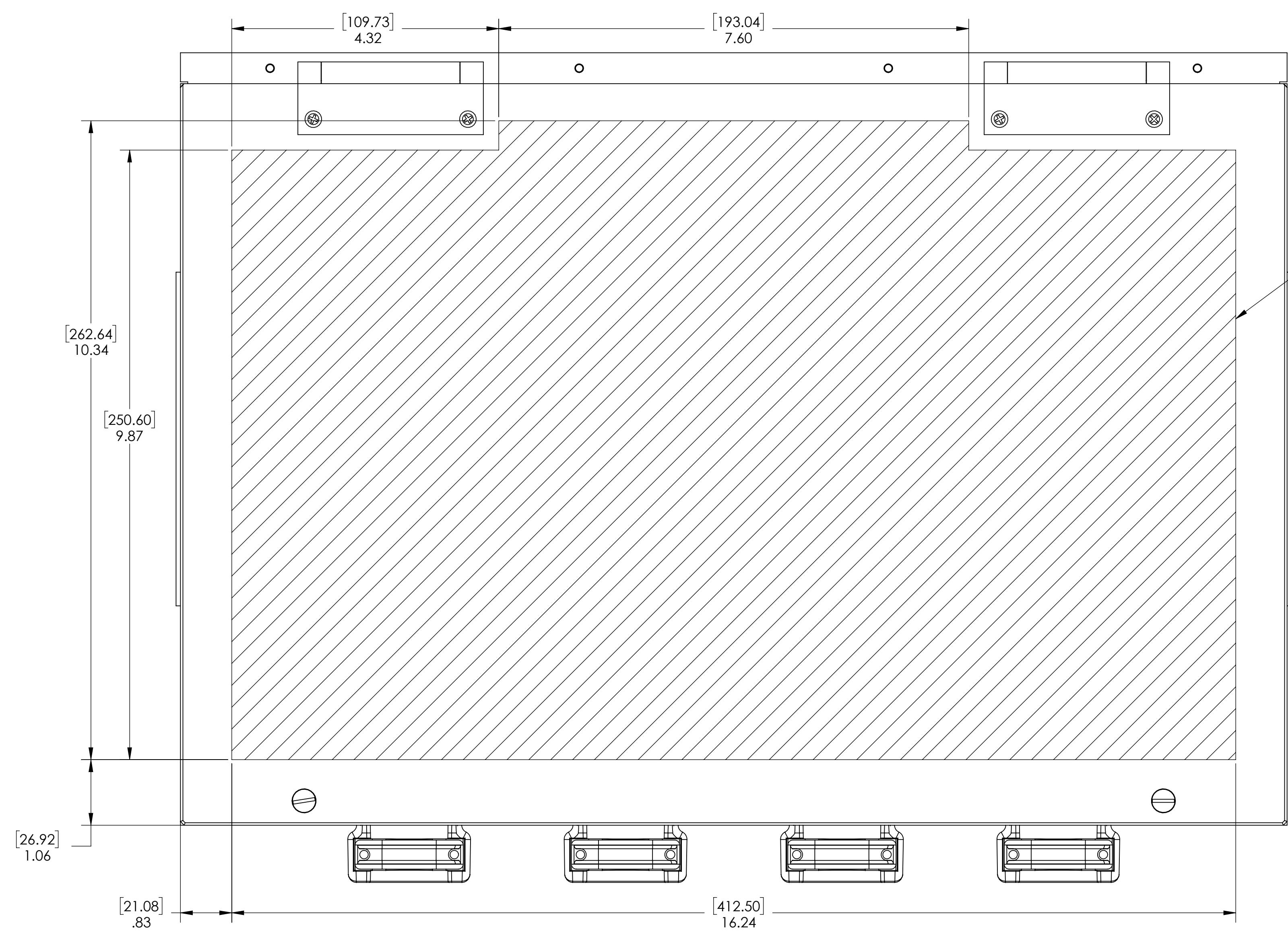

SHADED REGION REPRESENTS RECOMMENDED MACHINABLE AREA ON COVER. FEATURES OUTSIDE OF THIS REGION MAY INTERFERE WITH EXISTING COMPONENTS OR FEATURES.

**CUSTOMER DRAWING - CUSTOMER DRAWING - CUSTOMER DRAWING**

SIZE	CAGE CODE	DWG. NO.	REV
D	18117	410112712	F
SCALE: 4:5		410112712	8/16/2005 SHEET 2 OF 2

DO NOT SCALE DRAWING

8 7 6 5 4 3 2 1