

4

3

2

1

DO NOT SCALE DRAWING

THE INFORMATION CONTAINED HEREIN IS THE EXCLUSIVE PROPERTY OF VIRGINIA PANEL CORP. AND IS SUBMITTED FOR USE BY THE CUSTOMER ONLY. THE DATA SHALL NOT BE DUPLICATED, USED, OR DISCLOSED IN WHOLE OR IN PART FOR ANY PURPOSE OTHER THAN TO MAINTAIN THE EQUIPMENT PROVIDED. CONSULT WITH VIRGINIA PANEL CORPORATION ENGINEERING IF MORE DETAIL IS REQUIRED.

REVISIONS				
ZONE	REV	DESCRIPTION	DATE	APPROVED
	F	ECN#4243	9/4/12	SGM

D

D

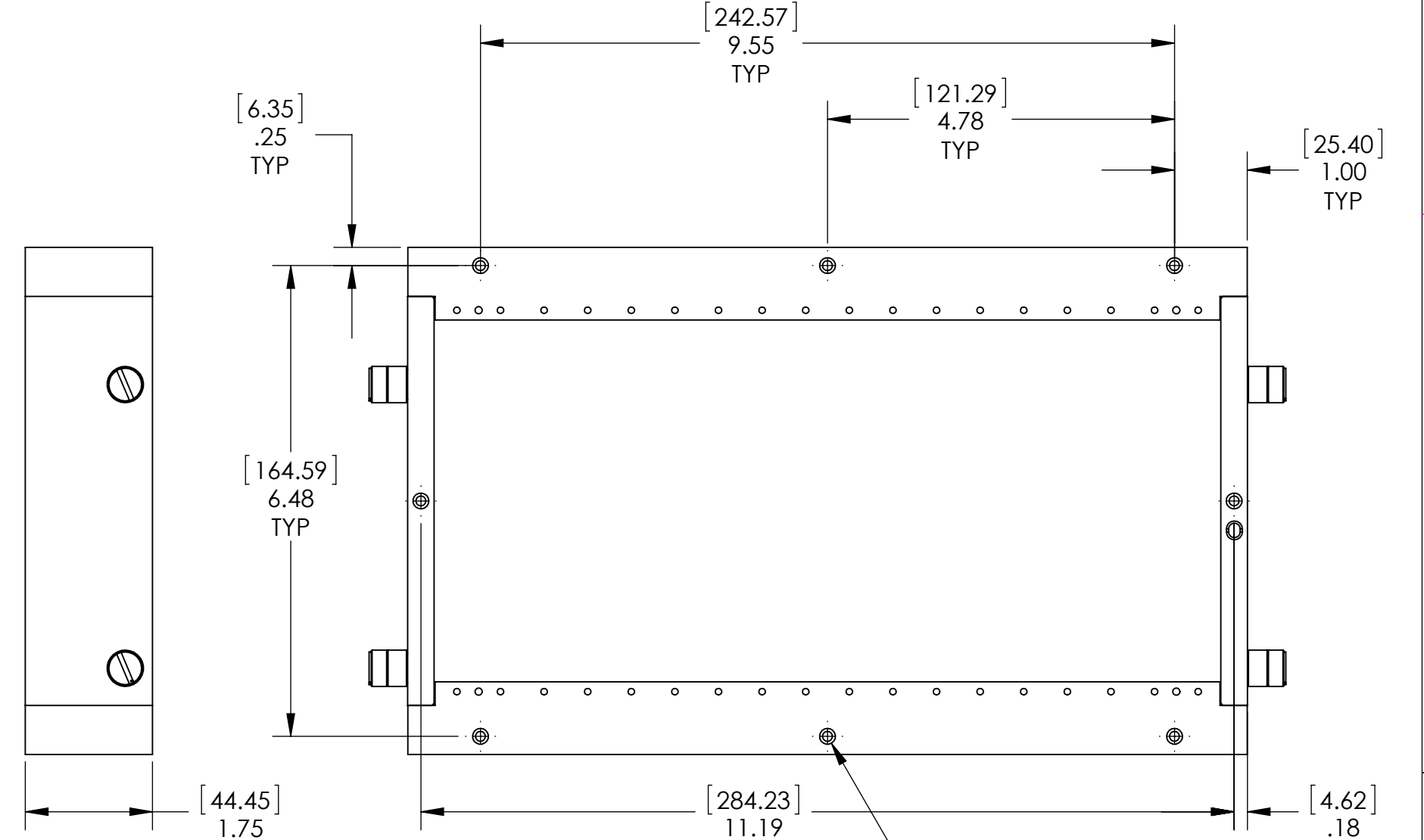
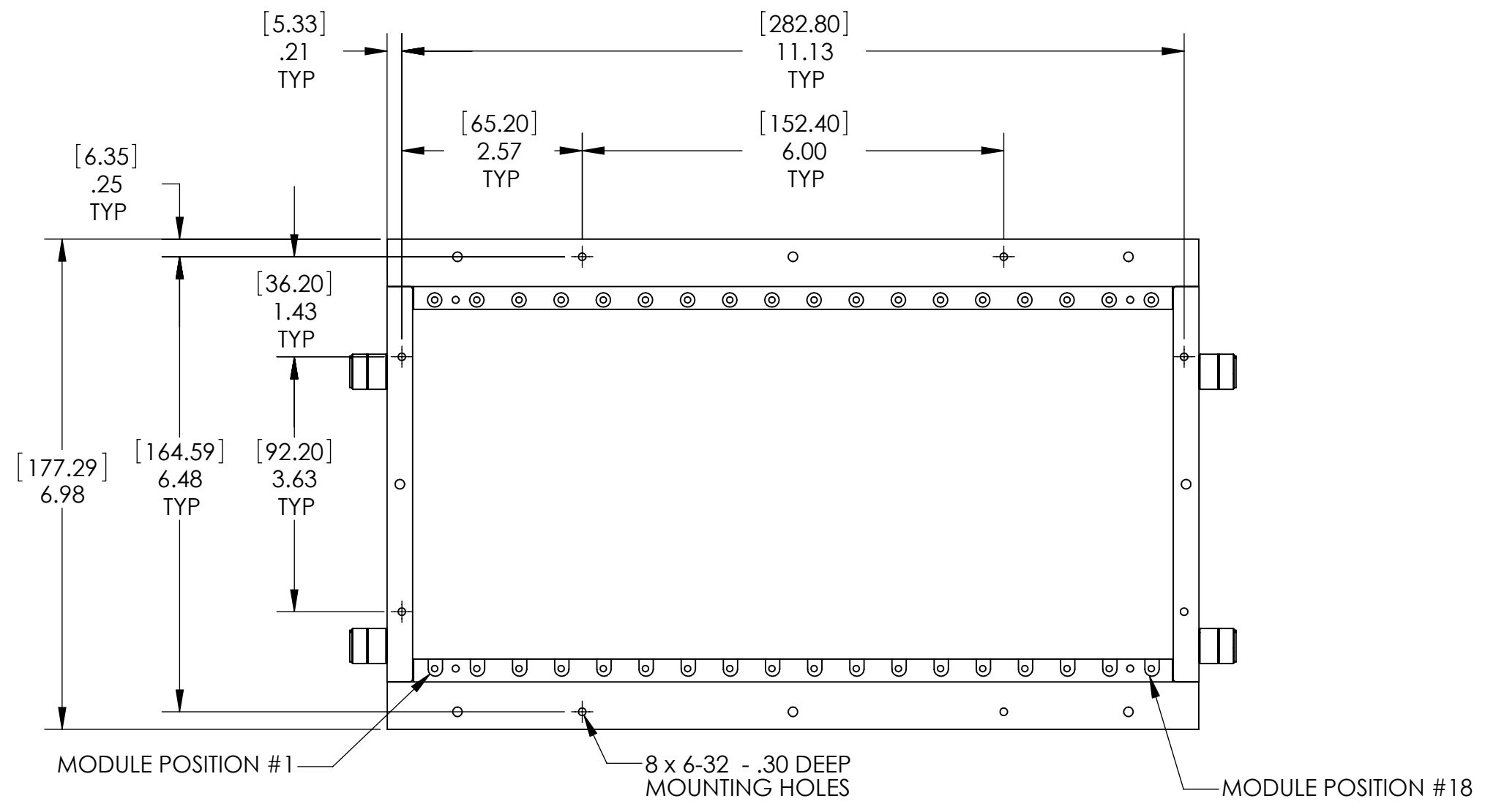

$\varnothing$  .136 [3.45] THRU ALL  
 $\varnothing$  .218 [5.54]  $\nabla$  .90 [22.86]  
 TYP. 8 PLCS.  
 FOR USE WITH FRONT  
 MOUNT ENCLOSURES

C

C

B

B

A

A

- NOTES:
- 2. APPROXIMATE WEIGHT: 3.28 LBS  
1.49 KG
  - 1. FOR APPLICATION, USE & CARE INFORMATION  
CONSULT VPC USERS GUIDE @WWW.VPC.COM

CUSTOMER DRAWING - CUSTOMER DRAWING

SOLIDWORKS DRAWING FILE	DIMENSIONS ARE SHOWN AS:		SIGNATURES		DATE	<b>VIRGINIA PANEL CORPORATION</b> WWW.VPC.COM		
	[millimeters] INCHES		DR	R TAYLOR	8/28/03			
	REMOVE BURRS. BREAK SHARP EDGES		CHK			ITA, G18, 18 MODULE		
	MATERIAL		ENG					
	FINISH		PROD			SIZE	FSCM NO.	DWG.NO.
		ASSY			C	18117	410120111	F
		QA			SCALE: NONE		410120111	8/28/03
		APPD						SHEET 1 OF 1

4

3

2

1