

8 7 6 5 4 3 2 1

DO NOT SCALE DRAWING

THE INFORMATION CONTAINED HEREIN IS THE EXCLUSIVE PROPERTY OF VIRGINIA PANEL CORP. AND IS SUBMITTED FOR USE BY THE CUSTOMER ONLY. THE DATA SHALL NOT BE DUPLICATED, USED, OR DISCLOSED IN WHOLE OR IN PART FOR ANY PURPOSE OTHER THAN TO MAINTAIN THE EQUIPMENT PROVIDED.

ZONE		REV	DESCRIPTION	DATE	APPROVED
E		ECN #6084		6/23/15	JTD

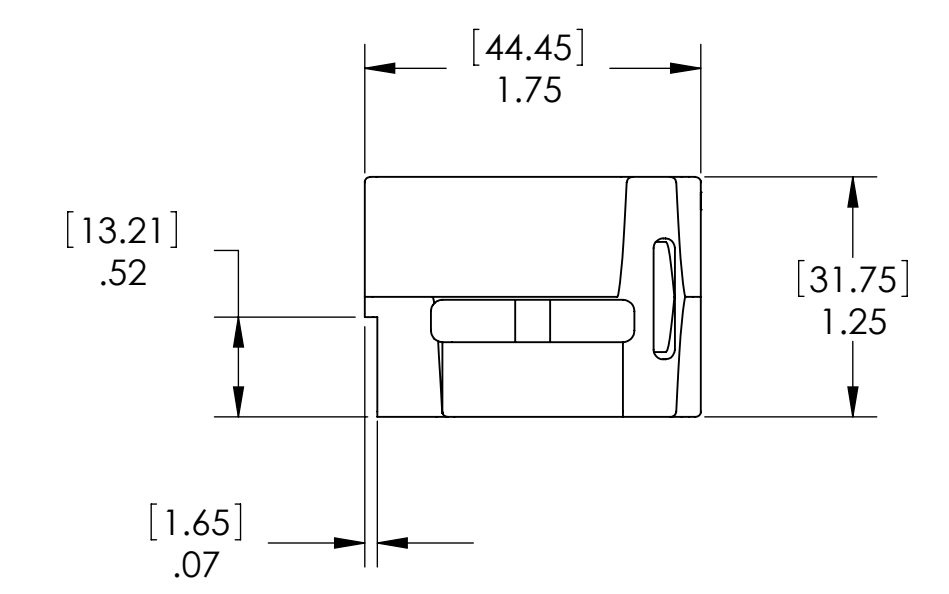
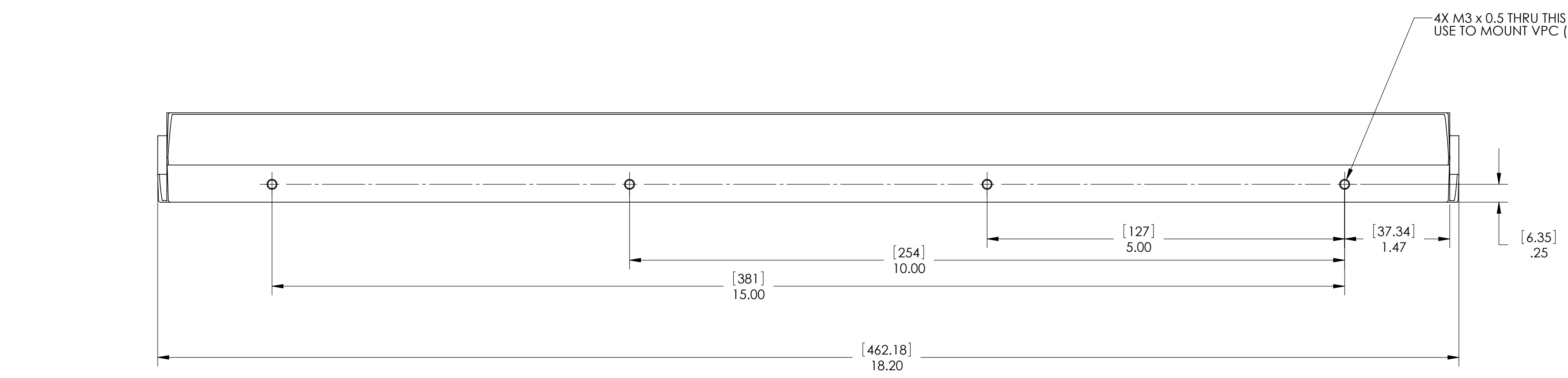
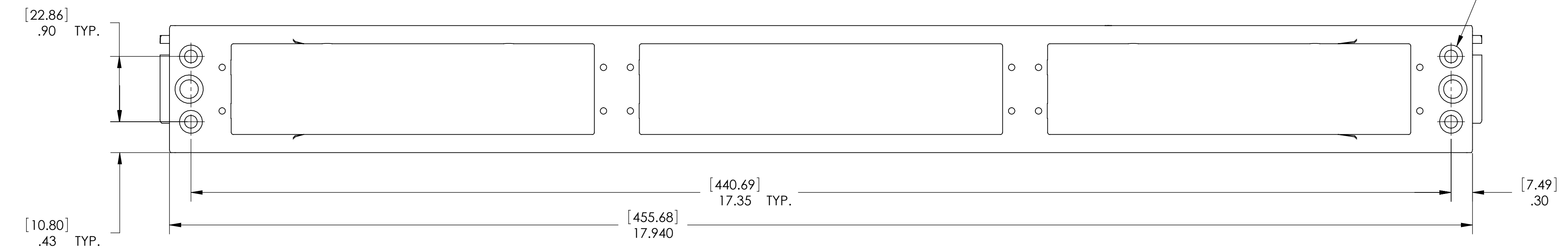
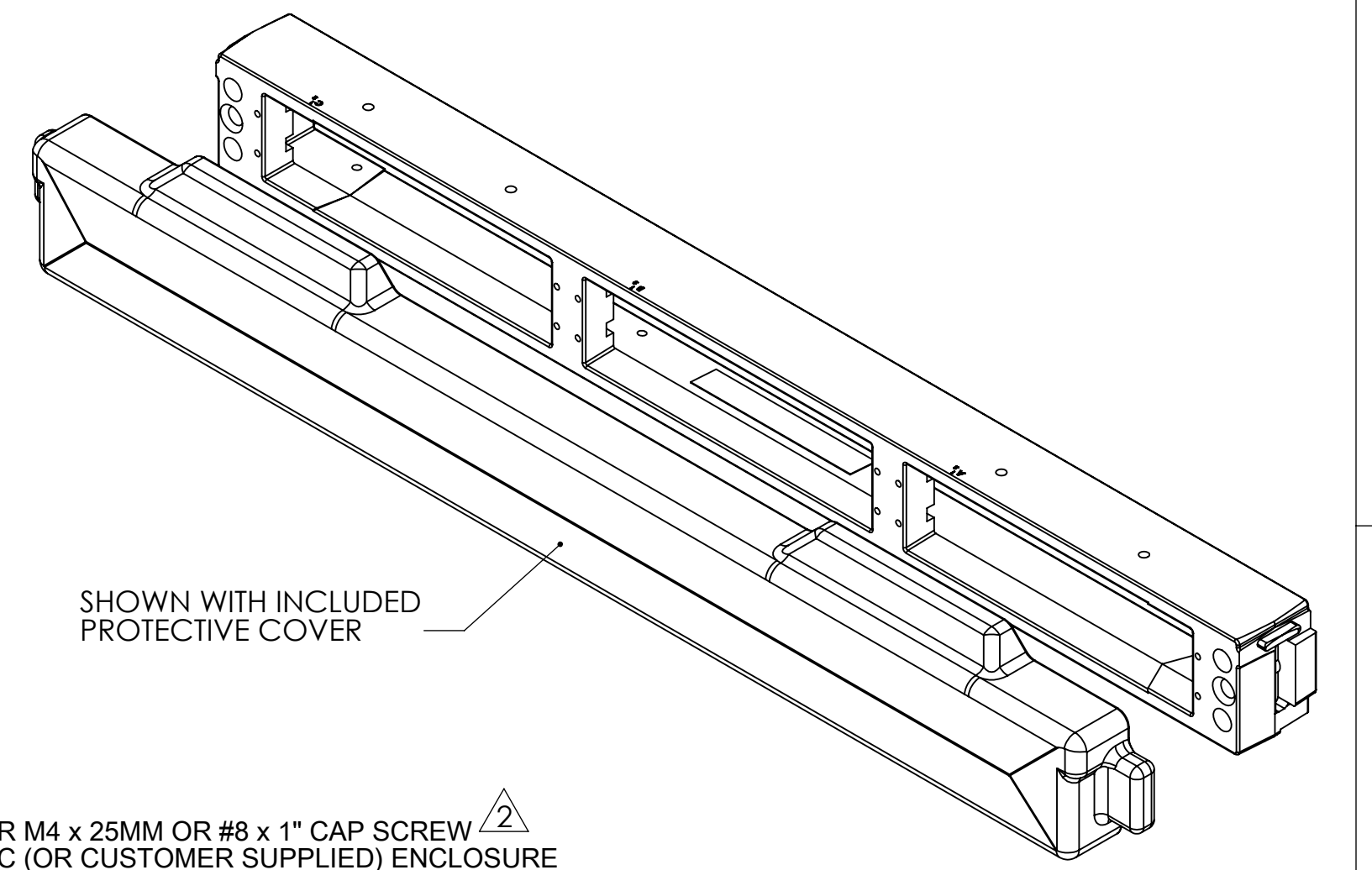
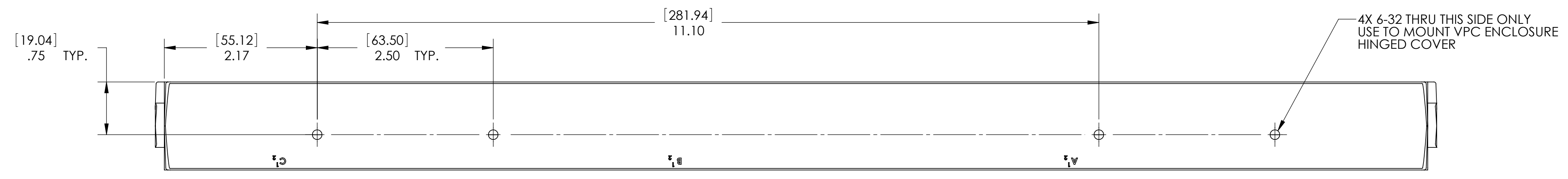

3. MATERIAL:
 FRAME: POWDER COATED - ZINC ALLOY
 COVER: VINYL

△ CUSTOMER SUPPLIED ENCLOSURES MUST HAVE A TOTAL SHEET METAL THICKNESS OF .060 - .070 INCHES (1.52-1.78 MM) THICK, INCLUDING PAINT, WITH MOUNTING HOLES DRILLED AT THE LOCATIONS SHOWN IN THE VIEWS ABOVE.

1 FOR APPLICATION, USE & CARE INFORMATION CONSULT VPC USERS GUIDE @WWW.VPC.COM.

NOTES:

DIMENSIONS ARE SHOWN AS: (millimeters) INCHES		CONTRACT NO.		VIRGINIA PANEL CORPORATION WWW.VPC.COM			
		SIGNATURES	DATE				
SOLIDWORKS DRAWING FILE	DR	R HERRON	6/24/2005	ITA, S6, 6 MODULE			
	CHK						
	ENG	R HERRON	6/24/2005				
	PROD						
MATERIAL	ASSY			SIZE	CAGE CODE	DWG NO.	REV
FINISH	APPD			D	18117	410122100	E
SCALE: 1:2		410122100	6/24/2005	SHEET 1			

8 7 6 5 4 3 2 1