

4

3

2

1

DO NOT SCALE DRAWING

THE INFORMATION CONTAINED HEREIN IS THE EXCLUSIVE PROPERTY OF VIRGINIA PANEL CORPORATION AND IS SUBMITTED FOR USE BY THE CUSTOMER ONLY. THE DATA SHALL NOT BE DUPLICATED, USED, OR DISCLOSED IN WHOLE OR IN PART FOR ANY PURPOSE OTHER THAN TO MAINTAIN THE EQUIPMENT PROVIDED. CONSULT WITH VIRGINIA PANEL CORPORATION ENGINEERING IF MORE DETAIL IS REQUIRED.

REVISIONS

REV	DESCRIPTION	DATE	ENGR
B	ECN #4278	10/01/12	S MARSHALL

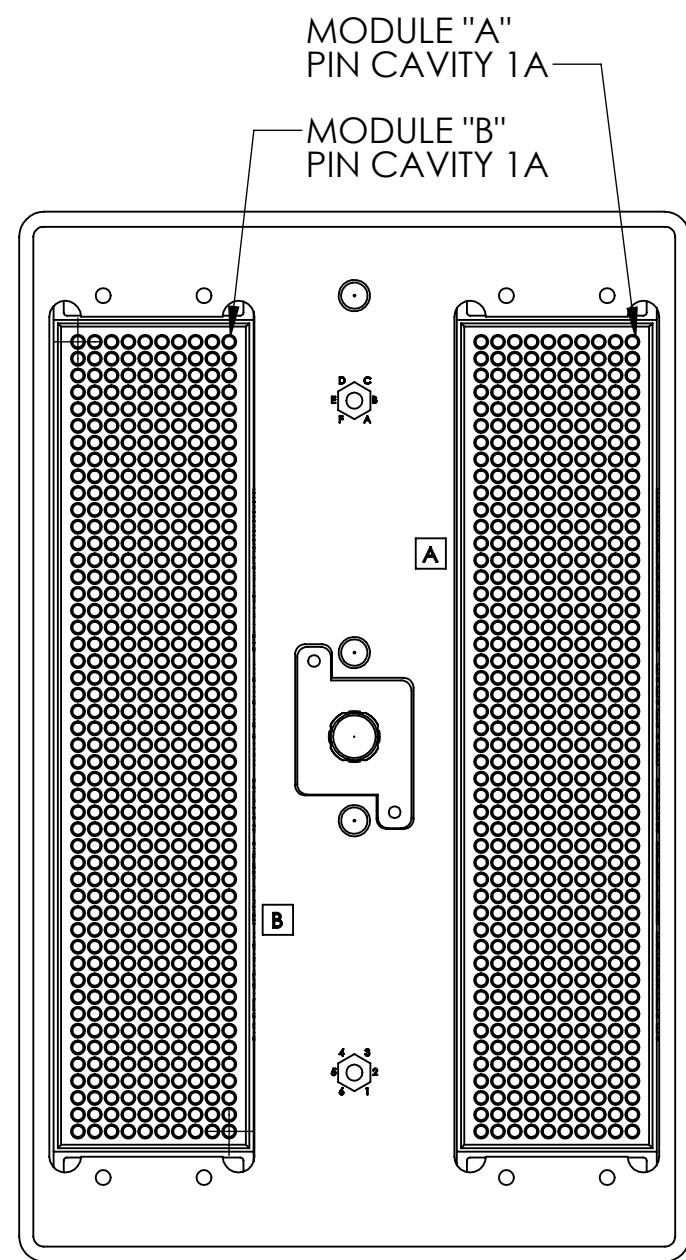
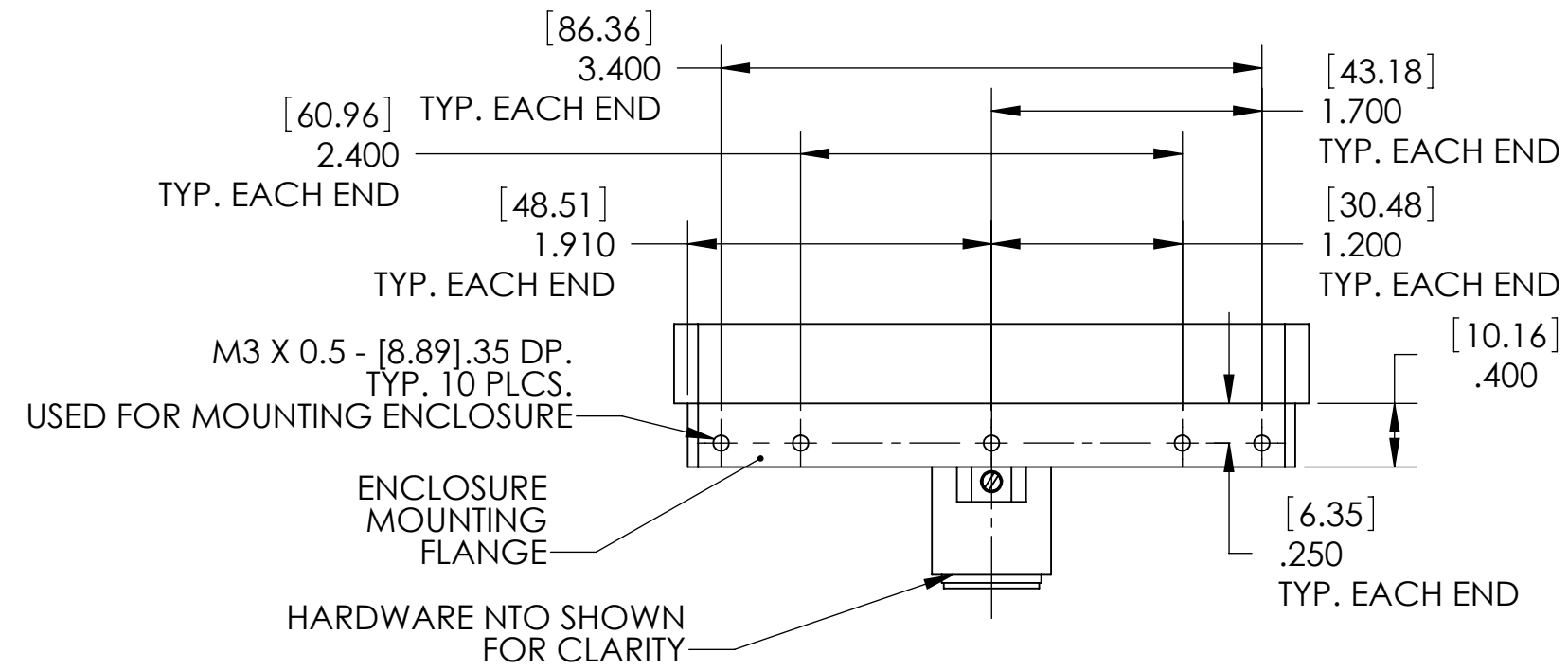

CONNECTOR MATING VIEW

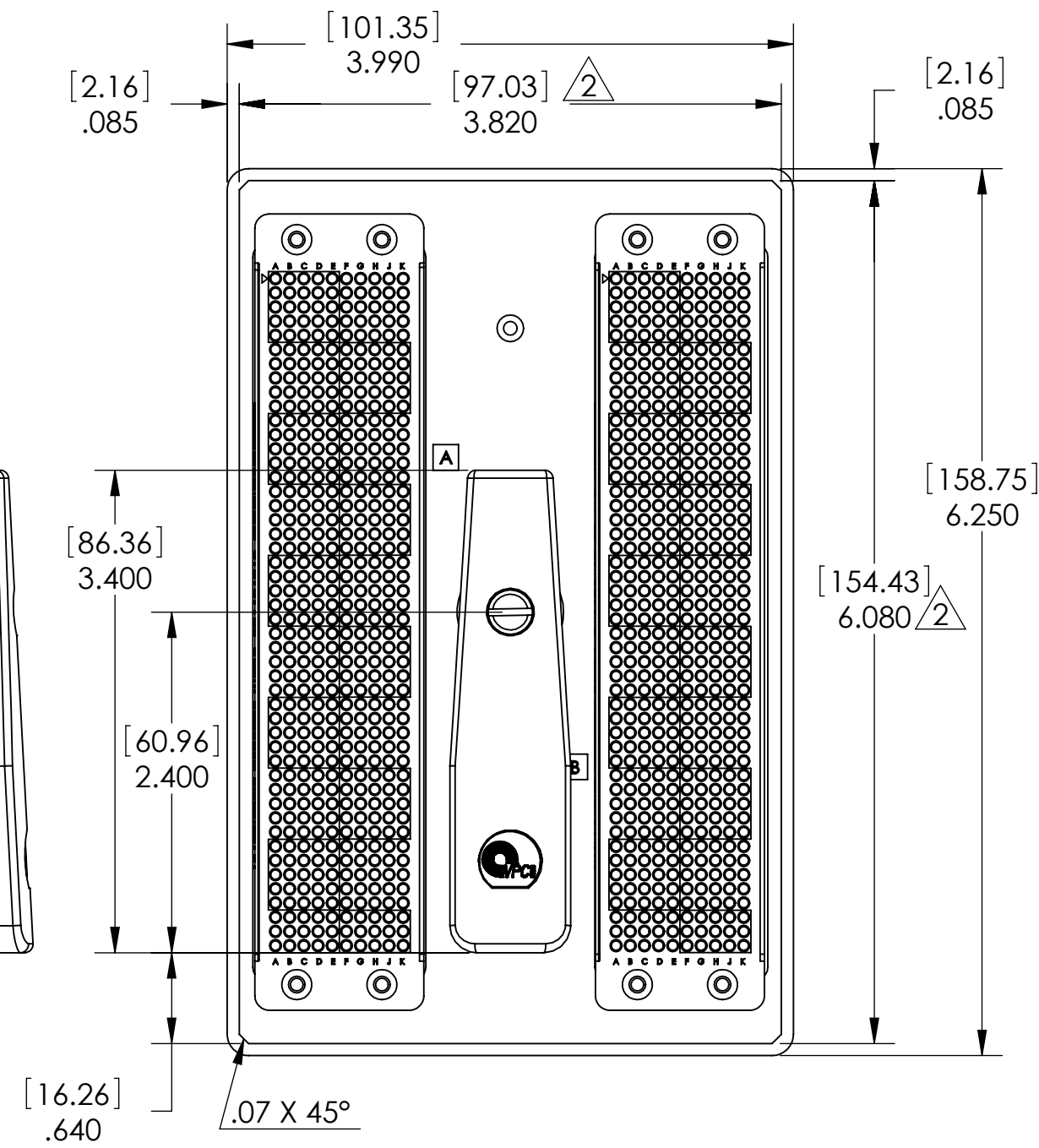
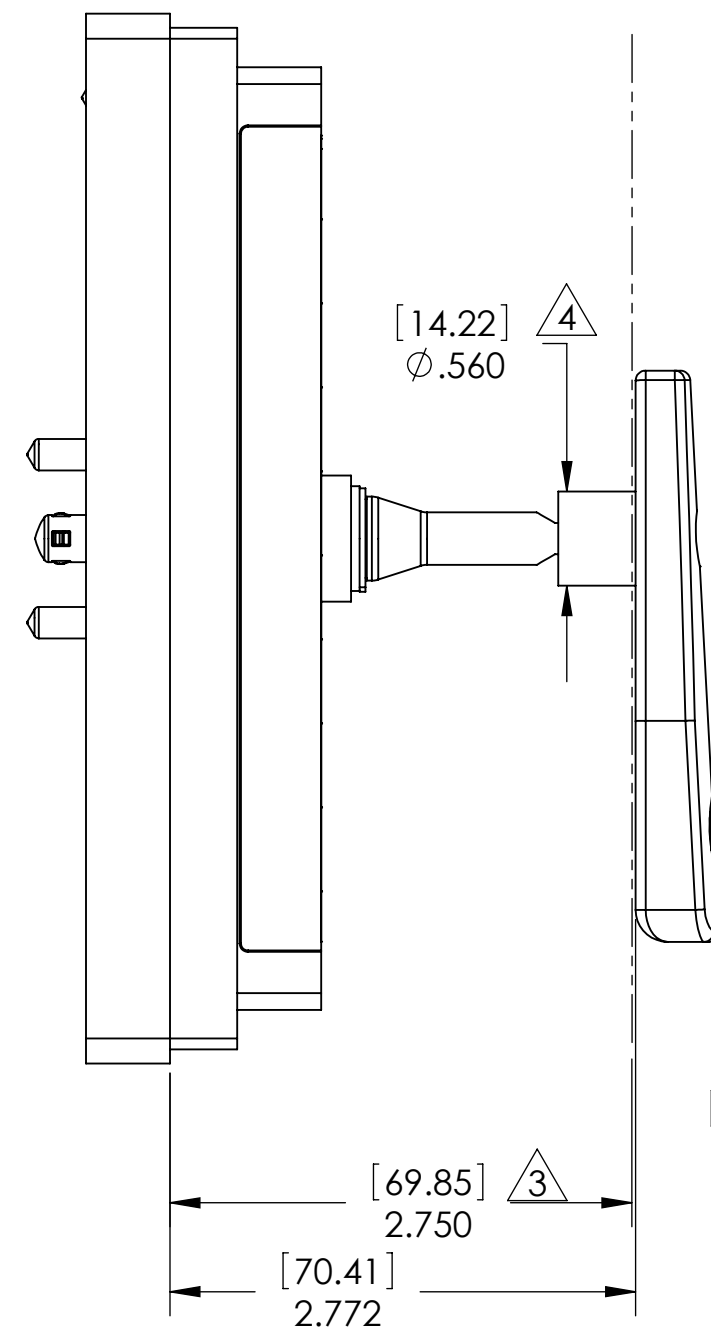

- 4 MINIMUM .60" Ø HOLE RECOMMENDED FOR HANDLE CLEARANCE IN ENCLOSURE
- 3 RECOMMENDED MAXIMUM EXTERNAL HEIGHT FOR ENCLOSURE
- 2 RECOMMENDED MINIMUM INTERNAL LENGTH AND WIDTH FOR ENCLOSURE
- 1 FOR APPLICATION USE & CARE INFORMATION CONSULT VPC USERS GUIDE @WWW.VPC.COM

NOTES:

DIMENSIONS ARE SHOWN AS:
[MILLIMETERS]
INCHES

CUSTOMER DRAWING			
VIRGINIA PANEL CORPORATION WWW.VPC.COM			
ICON 960 ITA w/ UNLOADED MODULES FOR DISCRETE WIRING			
SIZE	CAGE CODE	DWG. NO.	REV
C	18117	410124104	B
SCALE: 1:2	410124104	4/4/07	SHEET 1

4

3

2

1