

4

3

2

1

DO NOT SCALE DRAWING

THE INFORMATION CONTAINED HEREIN IS THE EXCLUSIVE PROPERTY OF VIRGINIA PANEL CORPORATION AND IS SUBMITTED FOR USE BY THE CUSTOMER ONLY. THE DATA SHALL NOT BE DUPLICATED, USED, OR DISCLOSED IN WHOLE OR IN PART FOR ANY PURPOSE OTHER THAN TO MAINTAIN THE EQUIPMENT PROVIDED. CONSULT WITH VIRGINIA PANEL CORPORATION ENGINEERING IF MORE DETAIL IS REQUIRED.

REVISIONS

REV	DESCRIPTION	DATE	ENGR
F	ECN #14975	5/9/25	RF

D

D

C

C

B

B

A

A

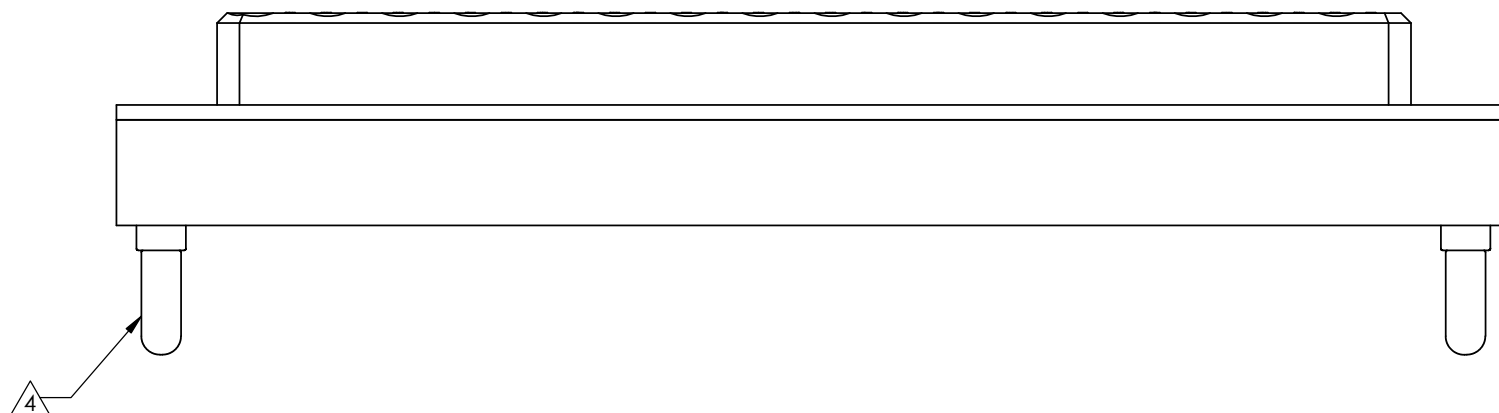
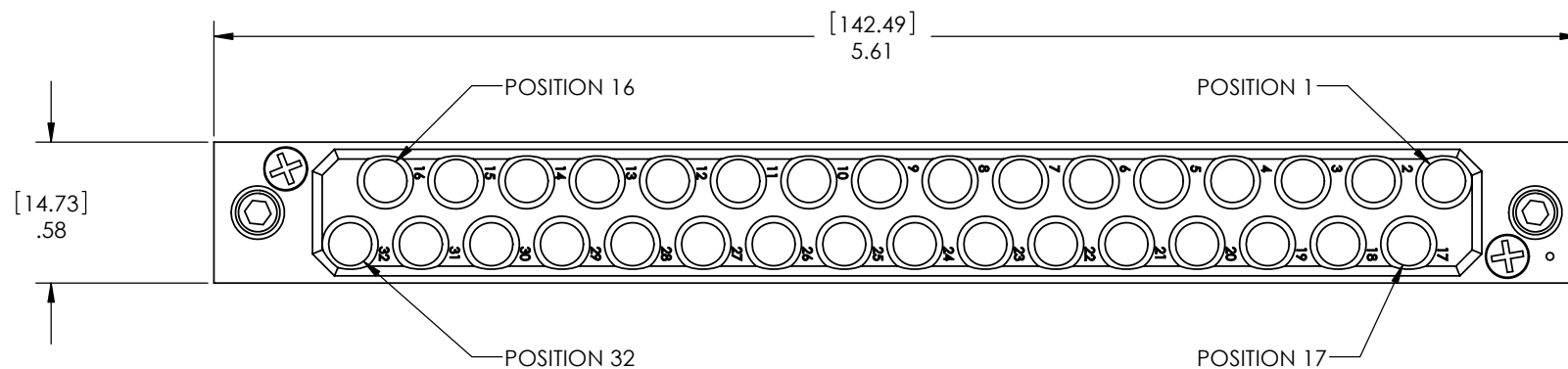

4 REMOVE BOOT FROM SCREW AND DISCARD BEFORE INSTALLATION INTO RECEIVER, TYP 2 PLCS.

3. MATING ITA MODULE: 510108179. USE WITH STANDARD (NON-HD) 75 OHM CONTACTS ONLY.

2. FOR CLARITY, WHITE SILKSCREENING IS SHOWN IN BLACK.

1. FOR APPLICATION USE & CARE INFORMATION CONSULT VPC USERS GUIDE @WWW.VPC.COM

NOTES:

DIMENSIONS ARE SHOWN AS:  
[MILLIMETERS]  
INCHES

<b>CUSTOMER DRAWING</b>			
<b>VIRGINIA PANEL CORPORATION</b> WWW.VPC.COM			
<b>COAXIAL MODULE, RECEIVER</b> <b>75 OHM, 32 POSITION</b>			
SIZE	CAGE CODE	DWG. NO.	REV
C	18117	<b>510104249</b>	F
SCALE: NONE	510104249	6/18/01	SHEET 1 OF 1

4

3

2

1