

DO NOT SCALE DRAWING

THE INFORMATION CONTAINED HEREIN IS THE EXCLUSIVE PROPERTY OF VIRGINIA PANEL CORPORATION AND IS SUBMITTED FOR USE BY THE CUSTOMER ONLY. THE DATA SHALL NOT BE DUPLICATED, USED, OR DISCLOSED IN WHOLE OR IN PART FOR ANY PURPOSE OTHER THAN TO MAINTAIN THE EQUIPMENT PROVIDED. CONSULT WITH VIRGINIA PANEL CORPORATION ENGINEERING IF MORE DETAIL IS REQUIRED.

REVISIONS			
REV	DESCRIPTION	DATE	ENGR
F	ECN # 3011	11/17/10	ECD

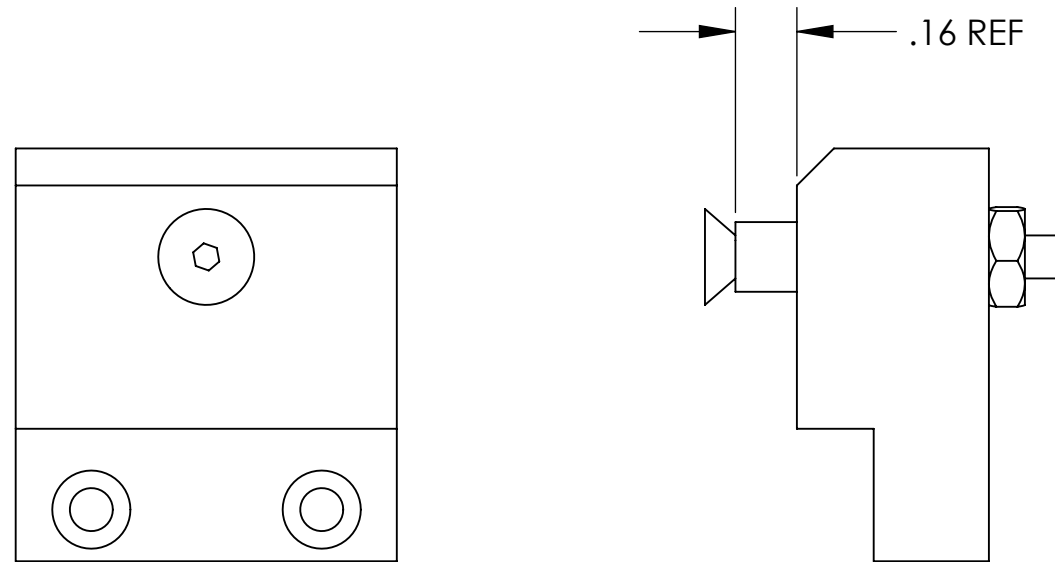

**CUSTOMER DRAWING**

**VIRGINIA PANEL CORPORATION**  
WWW.VPC.COM

**ADAPTER FOR  
DISCRETE WIRING**

2. ONLY ONE BLOCK SHOWN OF THE SET

1. FOR APPLICATION USE AND CARE INFORMATION CONSULT VPC USERS GUIDE @ WWW.VPC.COM

NOTES:

DIMENSIONS ARE SHOWN AS:	SIZE	CAGE CODE	DWG.NO.	REV
[MILLIMETERS] INCHES	B	18117	<b>510109117</b>	F
SCALE: 4:1		510109117	SHEET 1 OF 1	