

8 7 6 5 4 3 2 1

DO NOT SCALE DRAWING

THE INFORMATION CONTAINED HEREIN IS THE EXCLUSIVE PROPERTY OF VIRGINIA PANEL CORPORATION AND IS SUBMITTED FOR USE BY THE CUSTOMER ONLY. THE DATA SHALL NOT BE DUPLICATED, USED, OR DISCLOSED IN WHOLE OR IN PART FOR ANY PURPOSE OTHER THAN TO MAINTAIN THE EQUIPMENT PROVIDED. CONSULT WITH VIRGINIA PANEL CORPORATION ENGINEERING IF MORE DETAIL IS REQUIRED.

REVISIONS			
REV	DESCRIPTION	DATE	APPROVED
H	ECN #8841	1/30/19	R HERRON

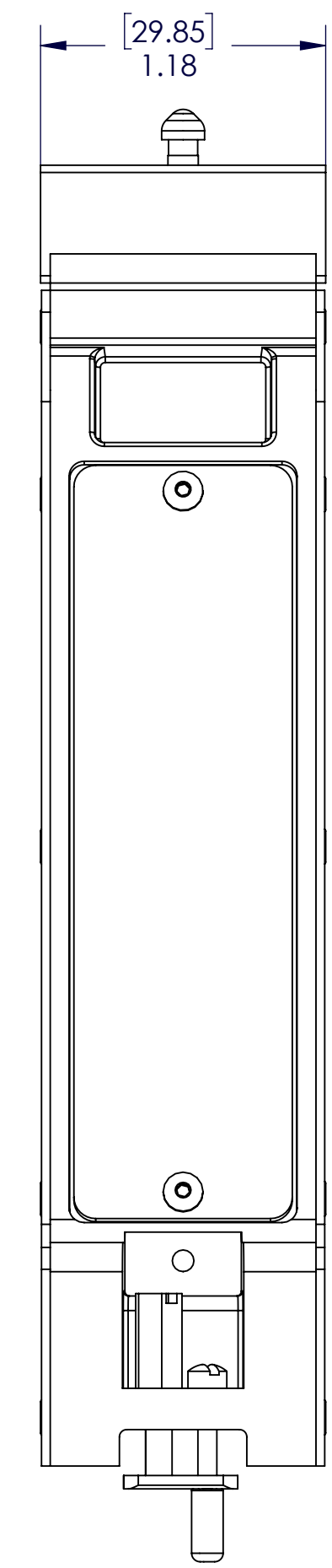
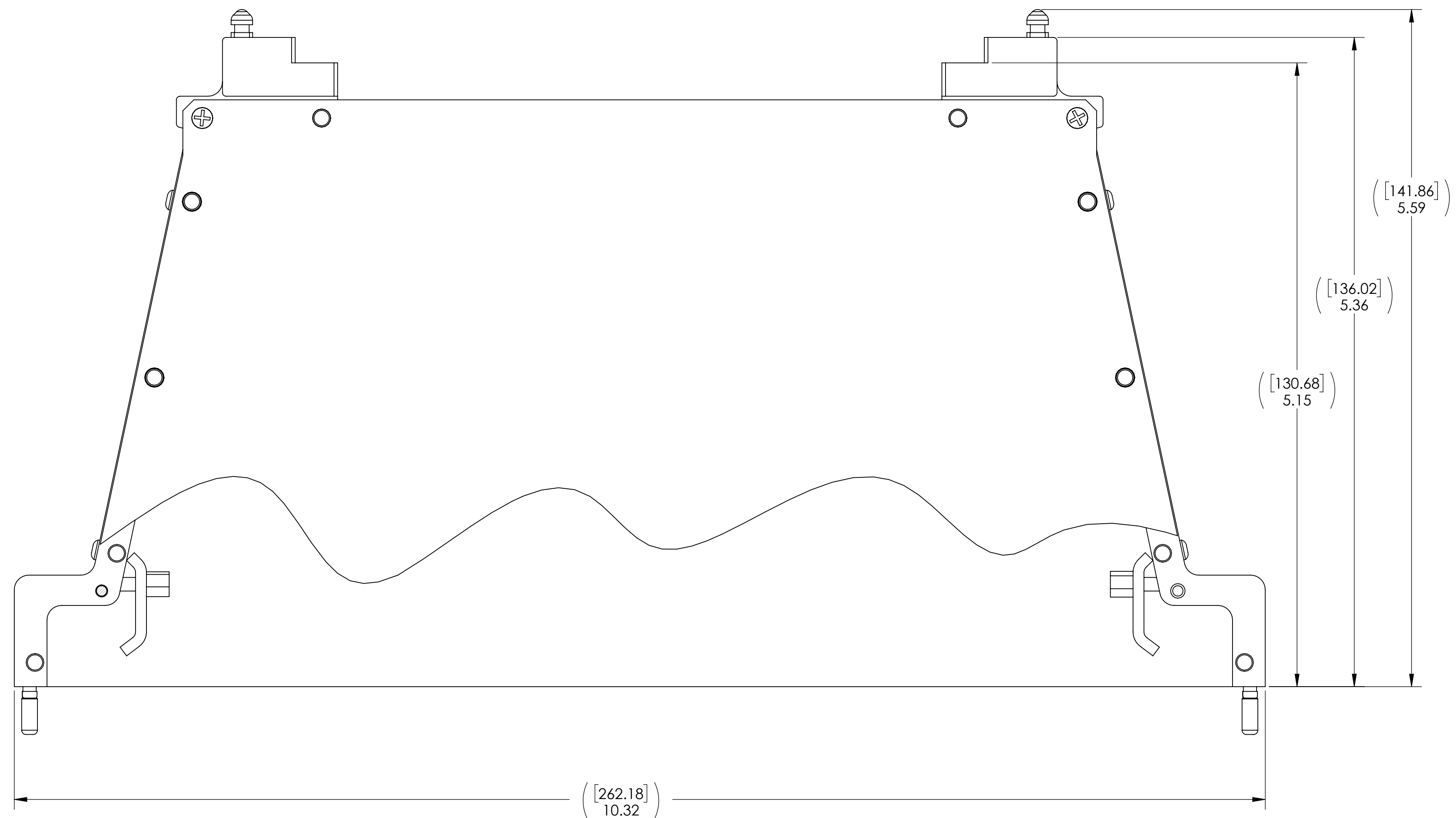
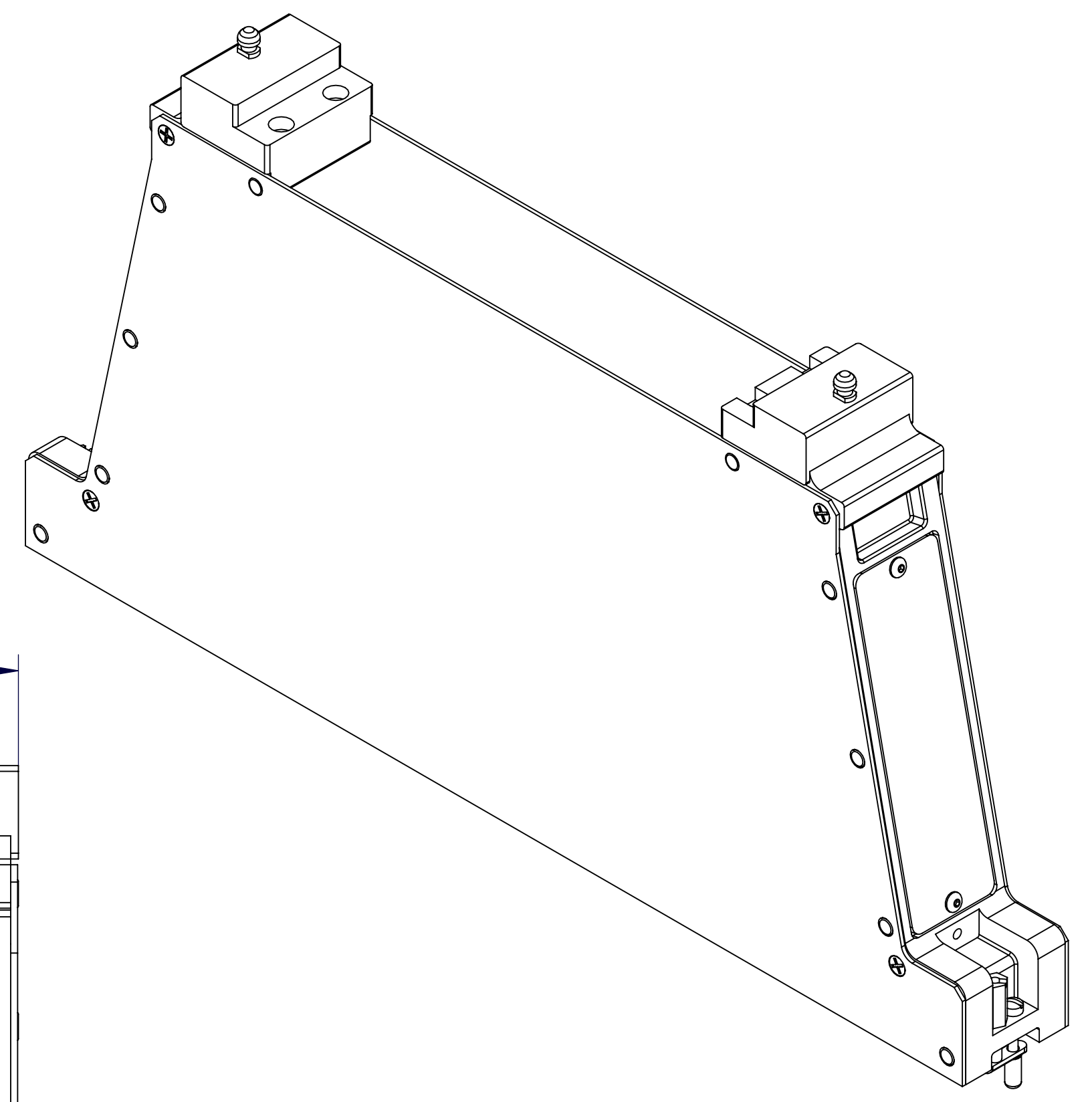
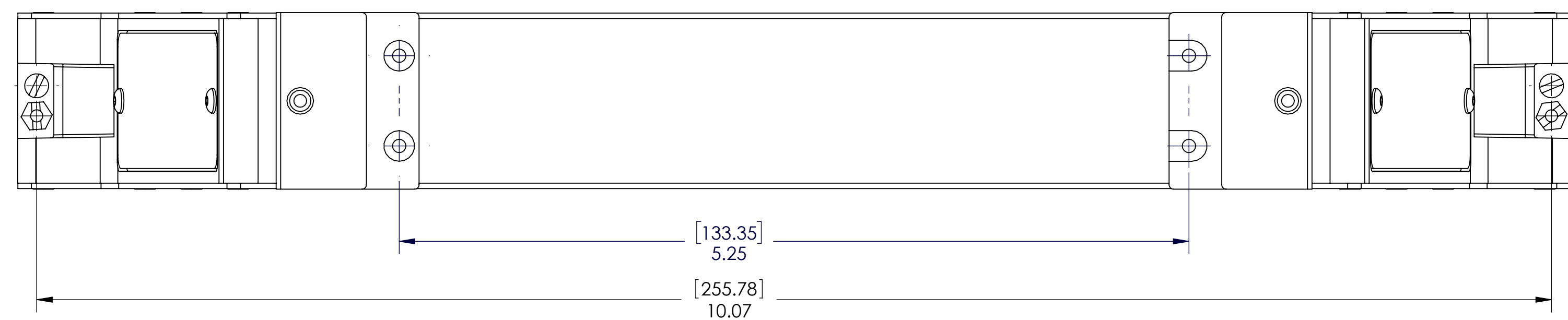

2. MATERIALS:  
 SIDE & END COVERS - STAINLESS STEEL  
 ALIGNMENT PINS - STAINLESS STEEL  
 ADAPTER TOP/BOTTOM - NICKEL PLATED DIE CAST ALUMINUM
1. FOR APPLICATION, USE & CARE INFORMATION  
 CONSULT VPC USERS GUIDE @WWW.VPC.COM.
- NOTES:

SOLIDWORKS DRAWING FILE	<b>CUSTOMER DRAWING - CUSTOMER DRAWING</b>				
	DIMENSIONS ARE SHOWN AS:		CONTRACT NO.		
	(millimeters) INCHES		SIGNATURES	DATE	
			DR R GARMAN	4/30/02	
	REMOVE BURRS. BREAK SHARP EDGES.		CHK		
	MATERIAL		ENG		
		PROD			
		ASSY			
		QA			
		APPD			
		SIZE	FSCM NO.	DWG NO.	REV
		D 18117		510109179	H
		SCALE: NONE	510109179	4/30/02	SHEET 1 OF 1

8 7 6 5 4 3 2 1