

8

7

6

5

4

3

2

1

DO NOT SCALE DRAWING

THE INFORMATION CONTAINED HEREIN IS THE EXCLUSIVE PROPERTY OF VIRGINIA PANEL CORPORATION AND IS SUBMITTED FOR USE BY THE CUSTOMER ONLY. THE DATA SHALL NOT BE DUPLICATED, USED OR DISCLOSED IN WHOLE OR IN PART FOR ANY PURPOSE OTHER THAN TO MAINTAIN THE EQUIPMENT PROVIDED. CONSULT WITH VIRGINIA PANEL CORPORATION ENGINEERING IF MORE DETAIL IS REQUIRED.

REVISIONS			
REV	DESCRIPTION	DATE	ENGR
B	ECN #7779	10/17/17	R GARMAN

D

D

C

C

B

B

A

A

SMP 1200 CARRIER  
SHOWN FOR REFERENCE ONLY

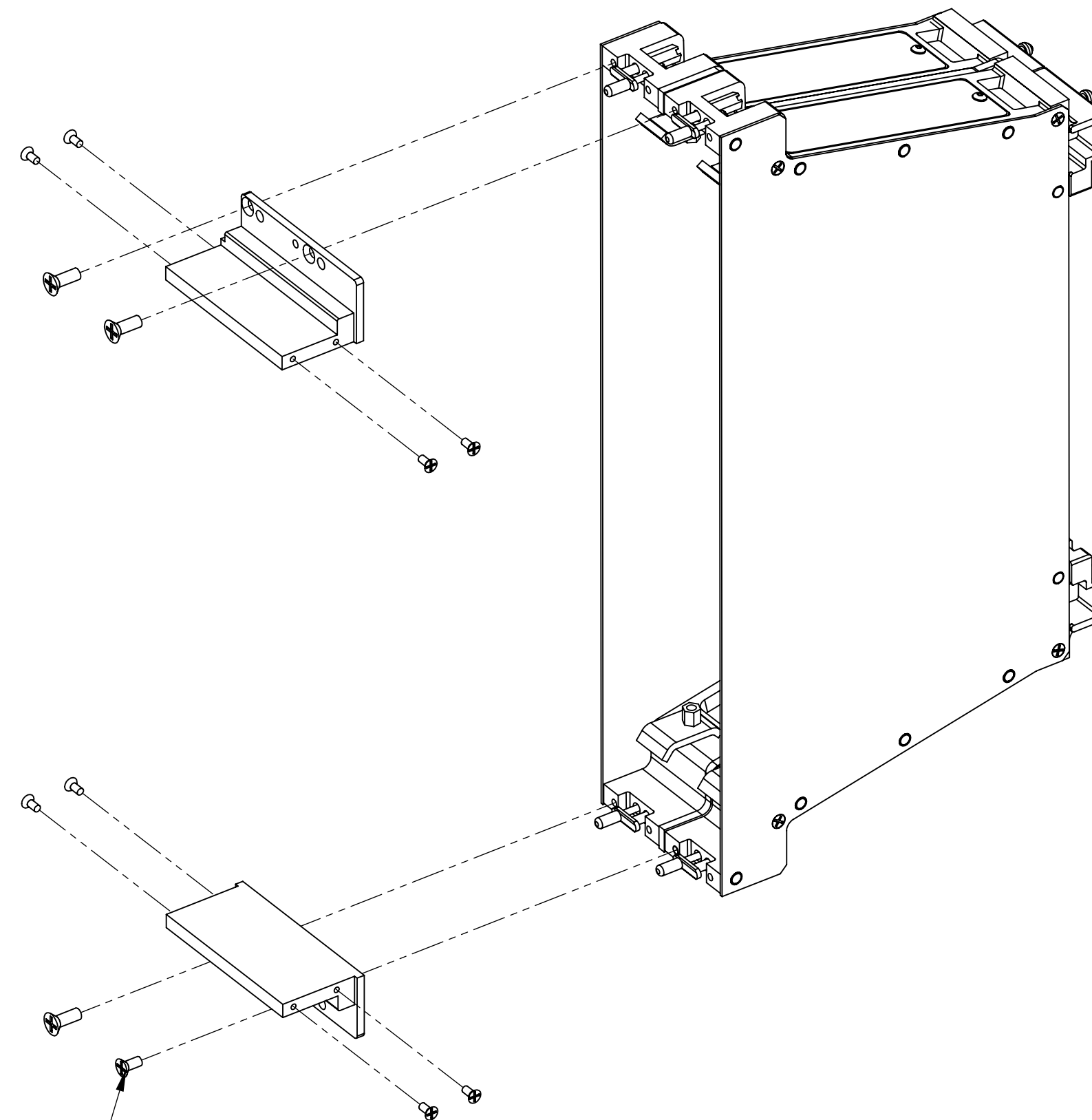
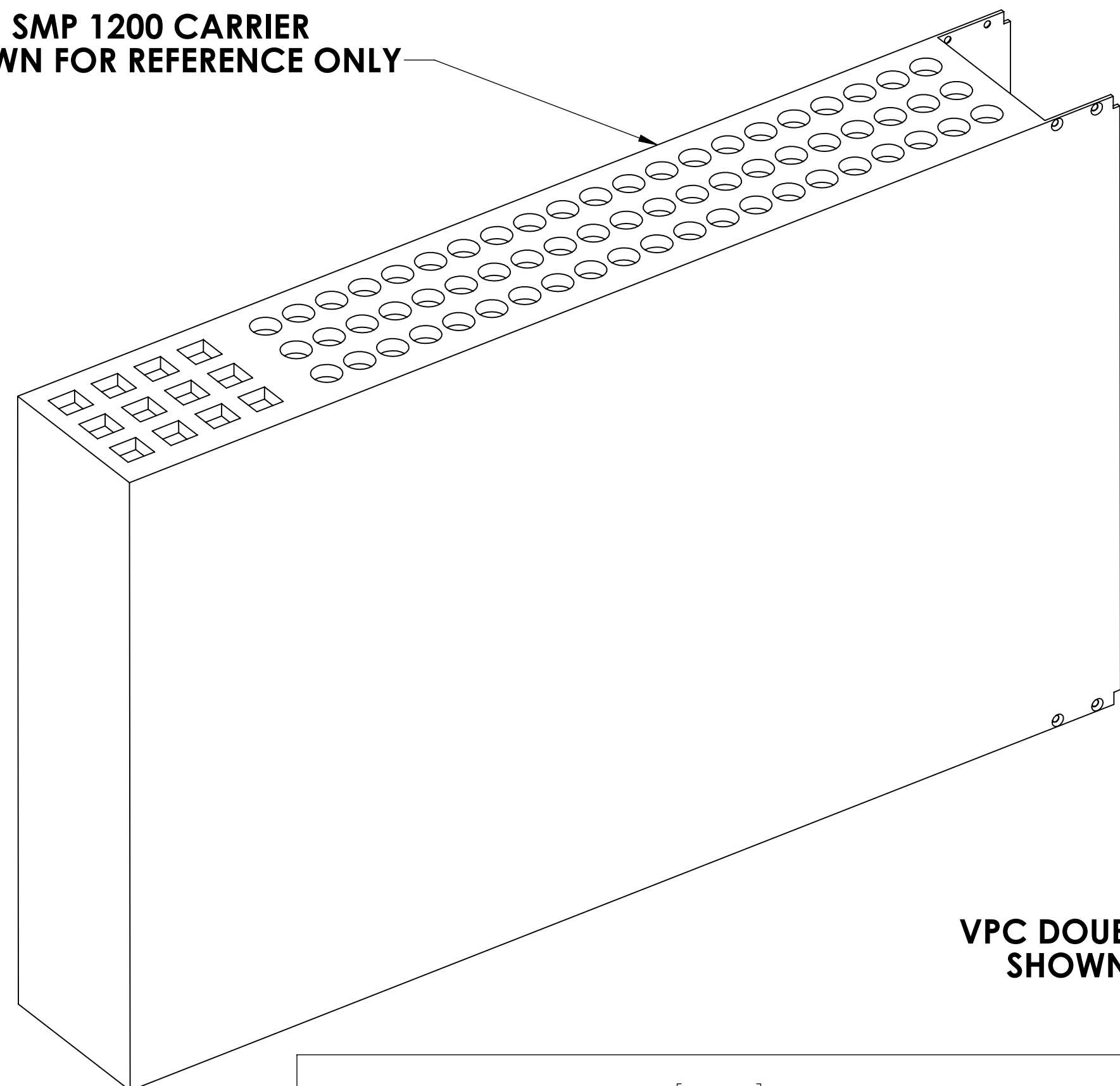

FLATHEAD PHILLIPS SCREW  
4-40 x 0.25 - 4 PLACES

VPC DOUBLE WIDE FUNNEL ADAPTER  
SHOWN FOR REFERENCE ONLY

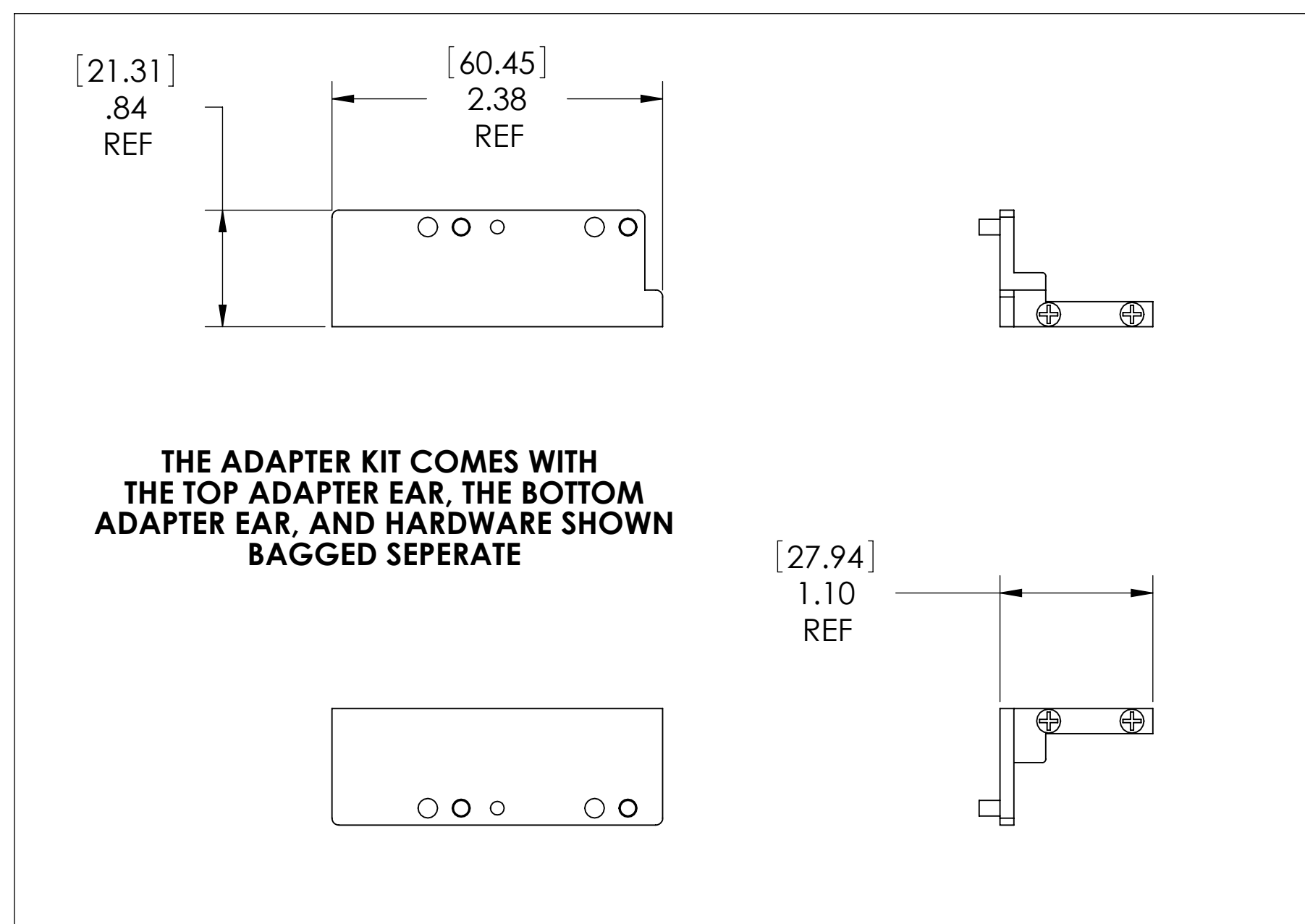

ADAPTER EAR, TOP

ADAPTER EAR, BOTTOM

FLATHEAD PHILLIPS SCREW  
2-56 x 0.187 - 8 PLACES

1. FOR APPLICATION USE AND CARE INFORMATION CONSULT VPC USERS GUIDE @ WWW.VPC.COM  
NOTES:

8

7

6

5

4

3

2

1

CUSTOMER DRAWING			
VIRGINIA PANEL CORPORATION WWW.VPC.COM			
DOUBLE WIDE FUNNEL ADAPTER FOR VXI SMP 1200 CARRIER			
DIMENSIONS ARE SHOWN AS:	SIZE	CAGE CODE	DWG. NO.
[MILLIMETERS]	D	18117	510109354
INCHES	SCALE: 1:1	510109354	SHEET 1 OF 1