

8 7 6 5 4 3 2 1

DO NOT SCALE DRAWING

THE INFORMATION CONTAINED HEREIN IS THE EXCLUSIVE PROPERTY OF VIRGINIA PANEL CORPORATION AND IS SUBMITTED FOR USE BY THE CUSTOMER ONLY. THE DATA SHALL NOT BE DUPLICATED, USED, OR DISCLOSED IN WHOLE OR IN PART FOR ANY PURPOSE OTHER THAN TO MAINTAIN THE EQUIPMENT PROVIDED CONSULT WITH VIRGINIA PANEL CORPORATION ENGINEERING IF MORE DETAIL IS REQUIRED.

REVISIONS			
REV	DESCRIPTION	DATE	ENGR
A	ORIGINAL RELEASE - ECU #05-510-0209	12/15/05	BM

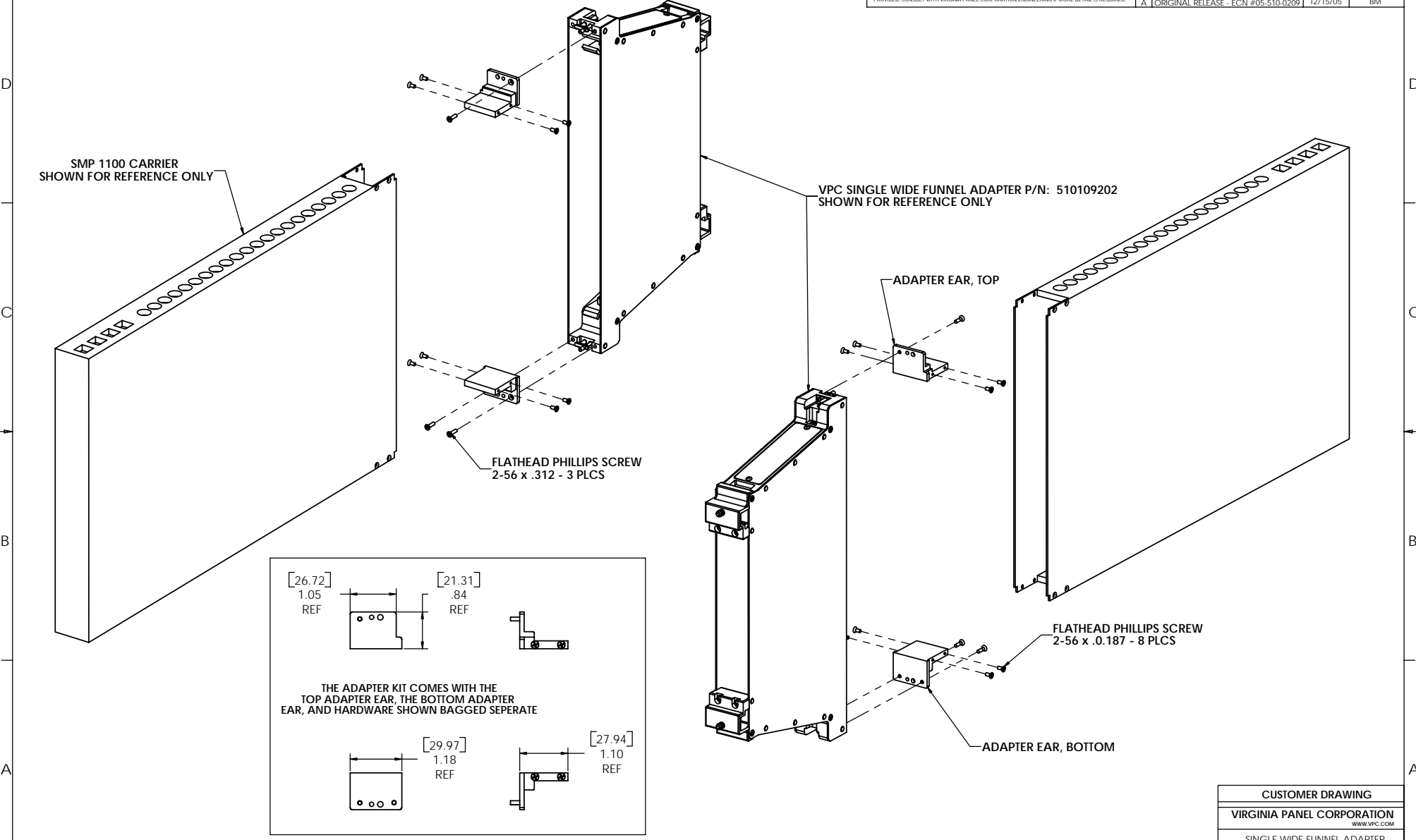

1. FOR APPLICATION USE AND CARE INFORMATION CONSULT VPC USERS GUIDE @ WWW.VPC.COM
NOTES:

8 7 6 5 4 3 2 1

CUSTOMER DRAWING			
VIRGINIA PANEL CORPORATION WWW.VPC.COM			
SINGLE WIDE FUNNEL ADAPTER FOR VXI SMP 1100 CARRIER			

DIMENSIONS ARE SHOWN AS:	SIZE	SCALE	CODE	DWG NO.	REV
(MILLIMETERS)	D	1:1		510109355	A
(INCHES)		SCALE: 1:1		510109355	SHEET 1 OF 1