

THE INFORMATION CONTAINED HEREIN IS THE EXCLUSIVE PROPERTY OF VIRGINIA PANEL CORPORATION AND IS SUBMITTED FOR USE BY THE CUSTOMER ONLY. THE DATA SHALL NOT BE DUPLICATED, USED, OR DISCLOSED IN WHOLE OR IN PART FOR ANY PURPOSE OTHER THAN TO MAINTAIN THE EQUIPMENT PROVIDED.

REV	DESCRIPTION	DATE	ENGINEER
A	ORIGINAL RELEASE ECN #6530	2/2/2016	C CHURCH

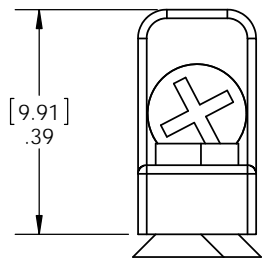
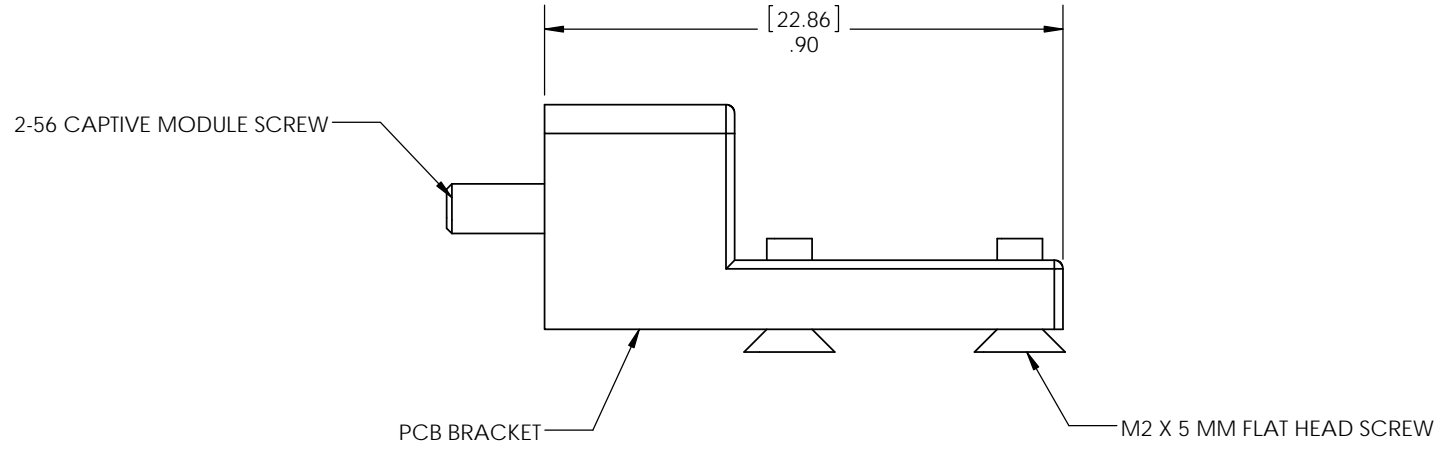
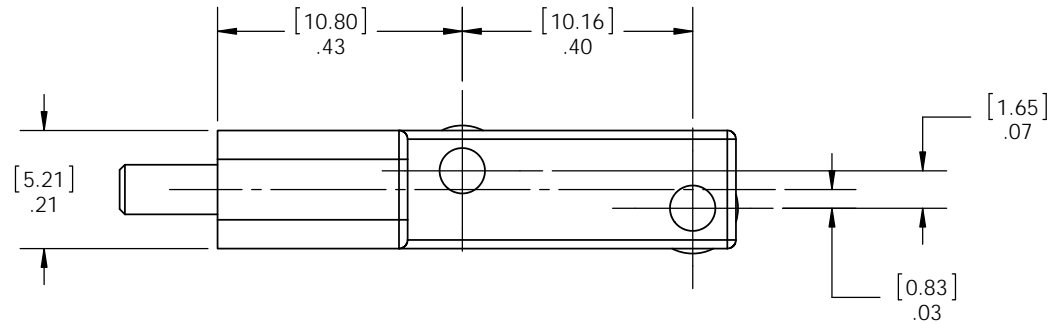

3. SET INCLUDES (2) BRACKETS, (2) 2-56 CAPTIVE MODULE SCREWS, & (4) M2 X 5 FLAT HEAD SCREWS
 2. MATERIAL = ZAMAK 3
 FINISH = NICKEL
 1. FOR APPLICATION USE AND CARE INFORMATION CONSULT VPC USERS GUIDE @ WWW.VPC.COM
 NOTES:

RELATIVE CONNECTOR POSITIONS AND WIRE ROUTING ARE GENERIC AND MAY VARY WITH PINOUT
 DIMENSIONS ARE SHOWN AS:
 [MILLIMETERS]
 INCHES

CUSTOMER DRAWING

**SIM VTAC HSD
PCB BRACKET SET**

DWG. NO.	510109592	REV	A
SCALE	3:1	CAGE CODE	18117
		SHEET	1 OF 1

