

DO NOT SCALE DRAWING

THE INFORMATION CONTAINED HEREIN IS THE EXCLUSIVE PROPERTY OF VIRGINIA PANEL CORPORATION AND IS SUBMITTED FOR USE BY THE CUSTOMER ONLY. THE DATA SHALL NOT BE DUPLICATED, USED, OR DISCLOSED IN WHOLE OR IN PART FOR ANY PURPOSE OTHER THAN TO MAINTAIN THE EQUIPMENT PROVIDED. CONSULT WITH VIRGINIA PANEL CORPORATION ENGINEERING IF MORE DETAIL IS REQUIRED.

REVISIONS			
REV	DESCRIPTION	DATE	ENGR
B	ECN #09-510-0090	10/16/09	BAL

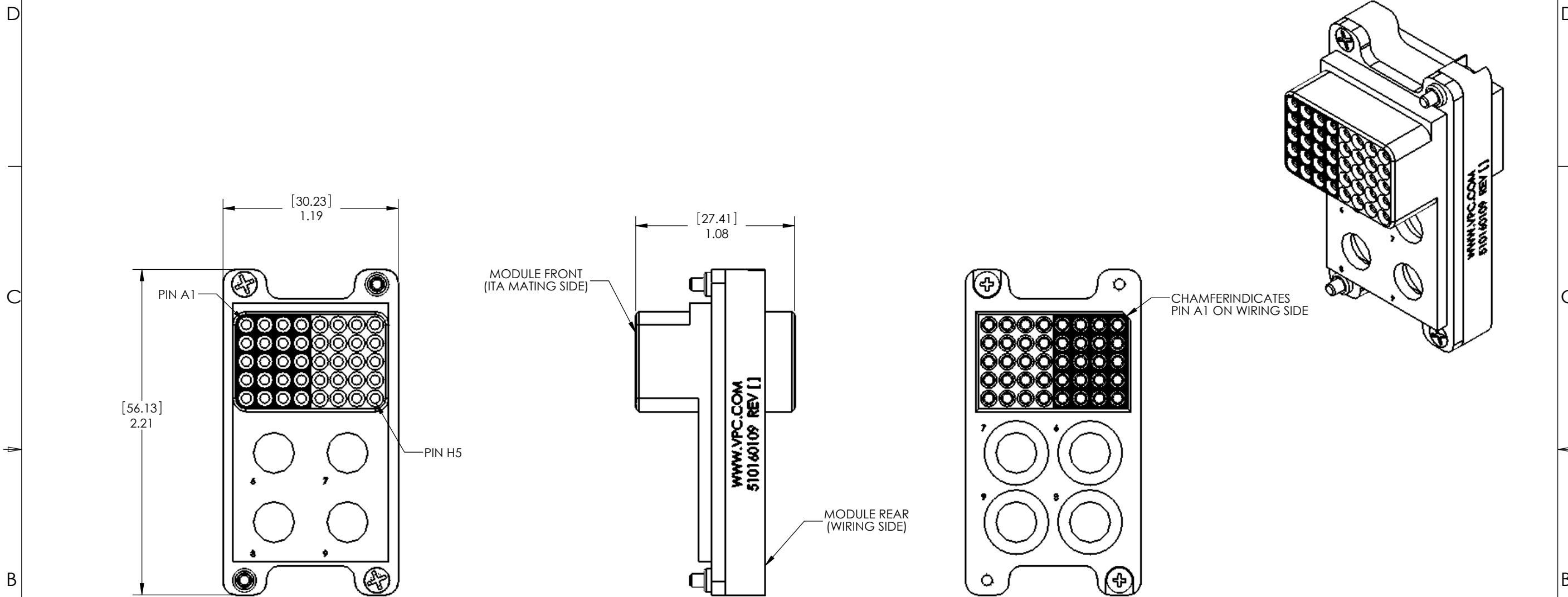

3. MATING MODULE: 510161109

2. MATERIALS:  
HOUSING: G10 - PAINTED BLACK  
MOUNTING HARDWARE: STAINLESS STEEL

1. FOR APPLICATION USE & CARE INFORMATION CONSULT VPC USERS GUIDE @WWW.VPC.COM  
NOTES:

**CUSTOMER DRAWING**

**VIRGINIA PANEL CORPORATION**  
WWW.VPC.COM

RECEIVER MODULE, ICON, HYBRID  
40 POS. TRIPADDER, 4 POS. TWINAX

DIMENSIONS ARE SHOWN AS:	SIZE	CAGE CODE	DWG. NO.	REV
[MILLIMETERS]	C	18117	510160109	B
INCHES	SCALE: 2:1	510160109	3/16/07	SHEET 1 OF 1