

4

3

2

1

DO NOT SCALE DRAWING

THE INFORMATION CONTAINED HEREIN IS THE EXCLUSIVE PROPERTY OF VPC AND IS PERMITTED FOR USE BY THE CUSTOMER ONLY. THE DATA SHALL NOT BE DUPLICATED, USED, OR DISCLOSED IN WHOLE OR IN PART FOR ANY PURPOSE OTHER THAN TO MAINTAIN THE EQUIPMENT PROVIDED. CONSULT WITH VPC ENGINEERING IF MORE DETAIL IS REQUIRED.

REVISIONS			
REV	DESCRIPTION	DATE	ENGR
D	ECN #15032	05/29/2025	C. Amaya

D

D

C

C

B

B

A

A

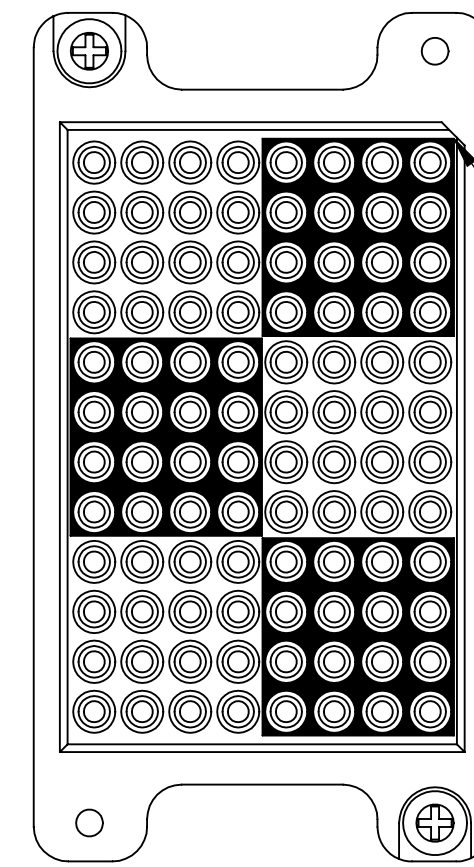
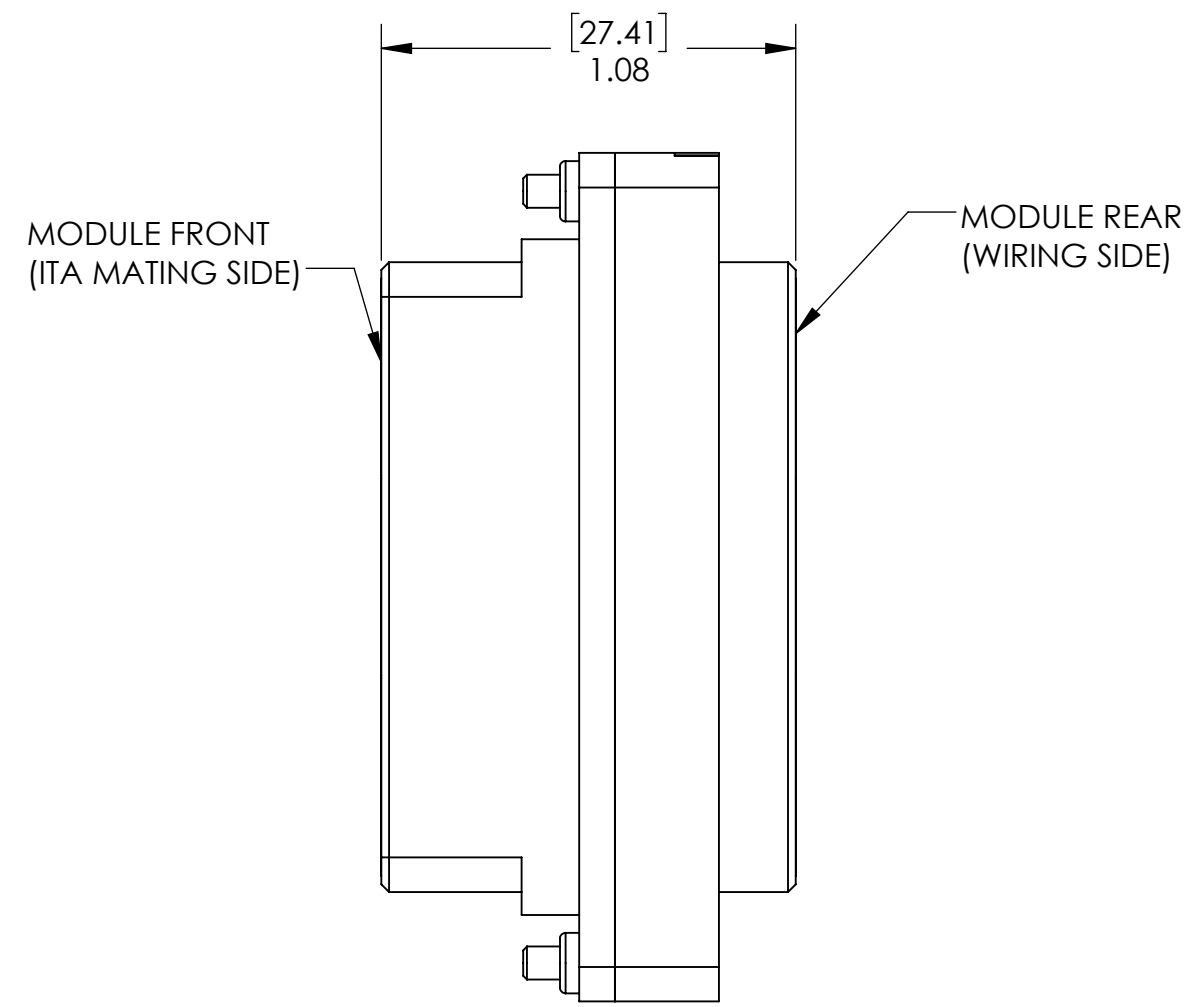
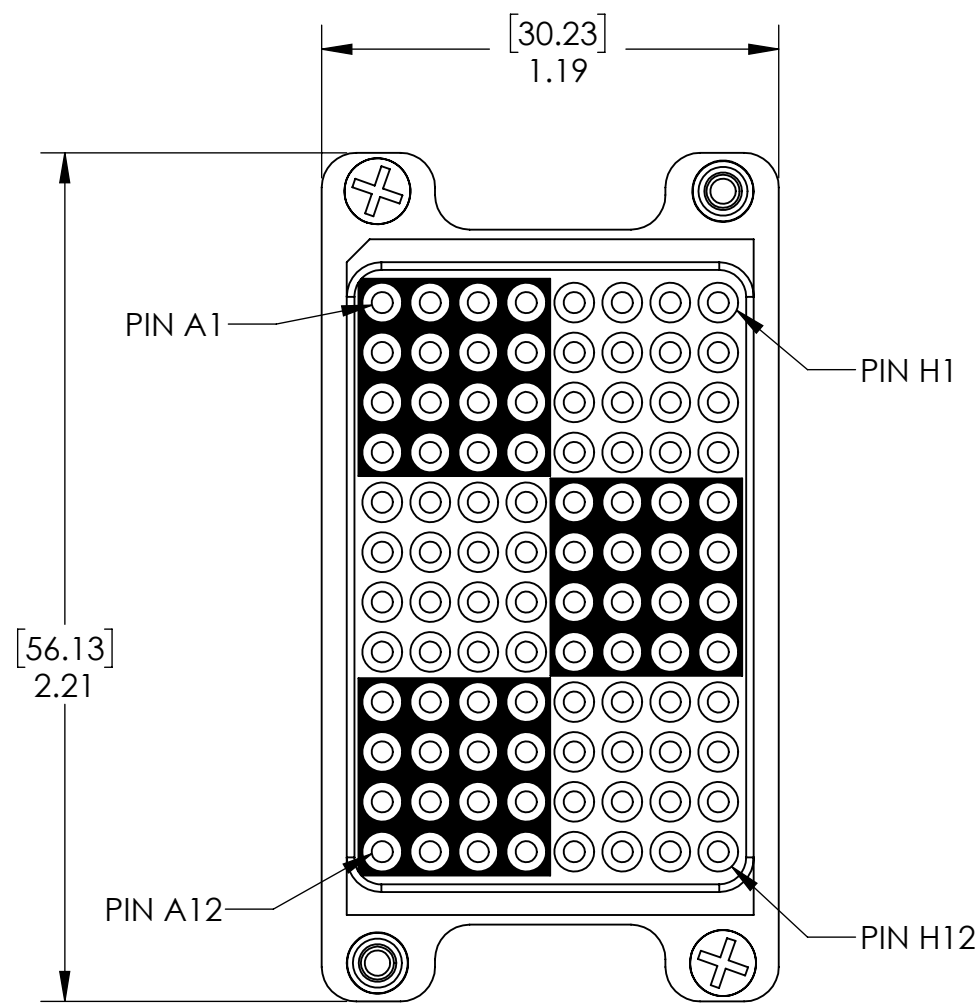
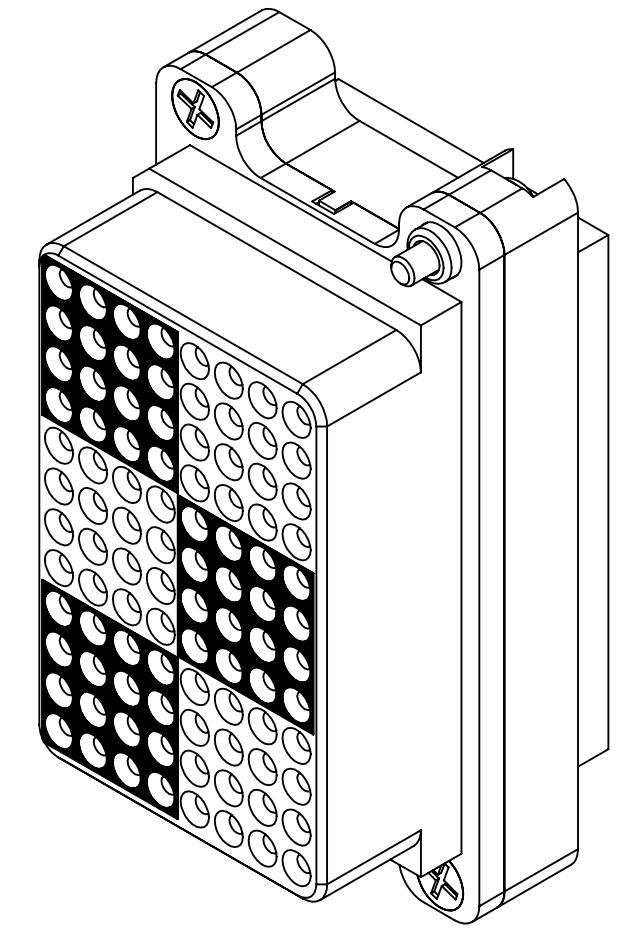

CHAMFER INDICATES PIN A1 ON WIRING SIDE

2. MATERIALS:
 HOUSING: BLACK G10
 MOUNTING HARDWARE: STAINLESS STEEL
 1. FOR MORE INFORMATION, VISIT VPC.COM.
 NOTES:

CUSTOMER DRAWING			
VIRGINIA PANEL CORPORATION WWW.VPC.COM			
THERMOCOUPLE, MOD, RCVR, iCON, 96 POS			
DIMENSIONS ARE SHOWN AS:	SIZE	CAGE CODE	DWG. NO.
[MILLIMETERS]	C	18117	510160110
INCHES			
SCALE: NONE	510160110	2/2/07	SHEET 1 OF 1

4

3

2

1