

THE INFORMATION CONTAINED HEREIN IS THE EXCLUSIVE PROPERTY OF VIRGINIA PANEL CORPORATION AND IS SUBMITTED FOR USE BY THE CUSTOMER ONLY. THE DATA SHALL NOT BE DUPLICATED, USED, OR DISCLOSED IN WHOLE OR IN PART FOR ANY PURPOSE OTHER THAN TO MAINTAIN THE EQUIPMENT PROVIDED.

REV	DESCRIPTION	DATE	ENGINEER
B	ECN #8596	10/3/2018	C CHURCH

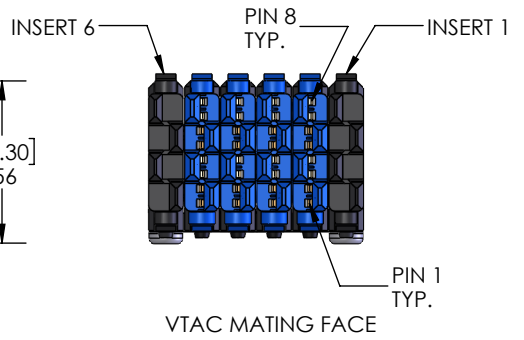
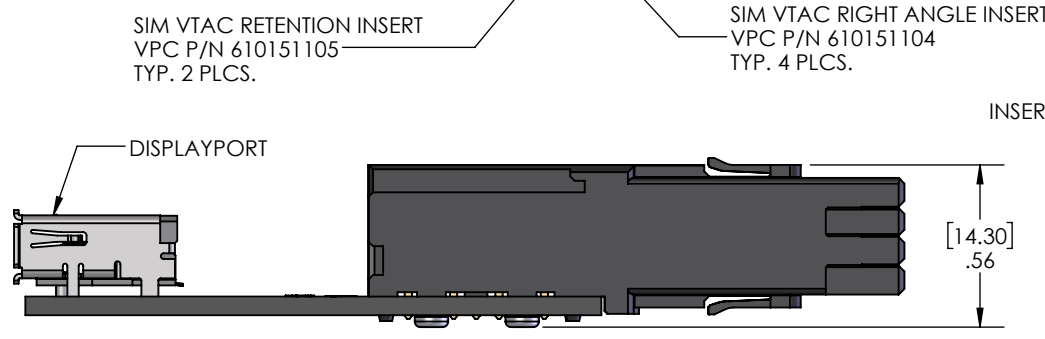
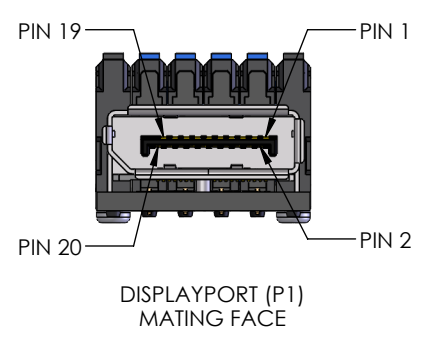
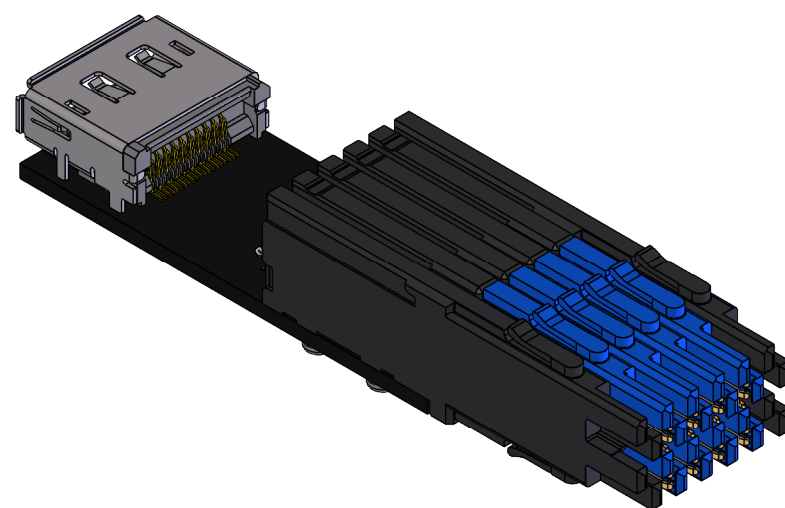
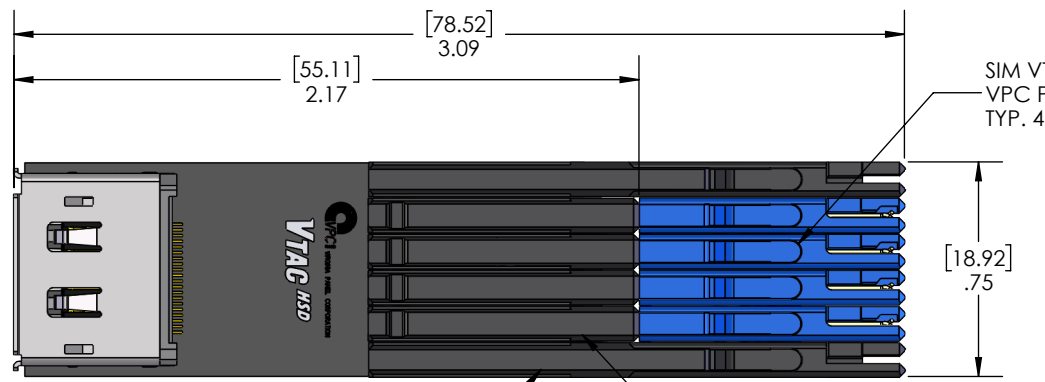

Run #	From VTAC Insert	From Pin	Signal Description	To Connector	To Pin
1		1	GND	Displayport (P1)	2, 5, 8, 11, 16, SHELL
2		2	CONFIG 2	Displayport (P1)	14
3		3	CONFIG 1	Displayport (P1)	13
4	2	4	GND	Displayport (P1)	2, 5, 8, 11, 16, SHELL
5		5	GND	Displayport (P1)	2, 5, 8, 11, 16, SHELL
6		6	AUX CH_P	Displayport (P1)	15
7		7	AUX CH_N	Displayport (P1)	17
8		4, 5, 8	GND	Displayport (P1)	2, 5, 8, 11, 16, SHELL
9	3	1	GND	Displayport (P1)	2, 5, 8, 11, 16, SHELL
10		2	ML_Lane 0_P	Displayport (P1)	1
11		3	ML_Lane 0_N	Displayport (P1)	3
12		4	GND	Displayport (P1)	2, 5, 8, 11, 16, SHELL
13		5	GND	Displayport (P1)	2, 5, 8, 11, 16, SHELL
14		6	ML_Lane 1_N	Displayport (P1)	6
15		7	ML_Lane 1_P	Displayport (P1)	4
16		8	GND	Displayport (P1)	2, 5, 8, 11, 16, SHELL

Run #	From VTAC Insert	From Pin	Signal Description	To Connector	To Pin
17		1	GND	Displayport (P1)	2, 5, 8, 11, 16, SHELL
18		2	ML_Lane 3_N	Displayport (P1)	12
19		3	ML_Lane 3_P	Displayport (P1)	10
20	4	4	GND	Displayport (P1)	2, 5, 8, 11, 16, SHELL
21		5	GND	Displayport (P1)	2, 5, 8, 11, 16, SHELL
22		6	ML_Lane 2_P	Displayport (P1)	7
23		7	ML_Lane 2_N	Displayport (P1)	9
24		8	GND	Displayport (P1)	2, 5, 8, 11, 16, SHELL
25	5	1	DP_PWR	Displayport (P1)	20
26		2	RETURN	Displayport (P1)	19
27		3	HPD	Displayport (P1)	18
28		4	GND	Displayport (P1)	2, 5, 8, 11, 16, SHELL
29		5	GND	Displayport (P1)	2, 5, 8, 11, 16, SHELL
30		6	GND	Displayport (P1)	2, 5, 8, 11, 16, SHELL
31		7	GND	Displayport (P1)	2, 5, 8, 11, 16, SHELL
32		8	GND	Displayport (P1)	2, 5, 8, 11, 16, SHELL

7. SIGNAL DESCRIPTIONS ARE BASED ON USE OF A SINGLE DISPLAYPORT CABLE CONNECTED TO A SINK DEVICE. THE DESCRIPTIONS REPRESENT THE SIGNALS ORIGINATING FROM A SOURCE DEVICE WHEN USED IN THIS CONFIGURATION. SIGNAL DESCRIPTIONS MAY CHANGE WHEN USED IN OTHER CONFIGURATIONS.

6. PCB DESIGNED TO BE LOADED ON THE RIGHT WHEN VIEWED FROM THE VPC ITA MATING FACE.
5. ASSEMBLY RETAINED IN MODULE BY RETENTION INSERT, P/N 610151105, ONLY. 2 EXTRACTION TOOL REQUIRED FOR REMOVAL.

4. PCB ASSEMBLY COMES WITH PASS THROUGH INSERT, P/N 610151103, ASSEMBLED ONTO RIGHT ANGLE INSERT P/N 610151104.

3. PCB ASSEMBLY REQUIRES 6 EMPTY VTAC MODULE POSITIONS.

2. MATERIALS:
PCB:
PCB = MEGTRON-6
PCB PADS = GOLD IMMERSION
VTAC INSERTS:
VTAC CONTACT = ALLOY 7025
OUTER SHELL = BLUE/BLACK LCP
DISPLAYPORT RECEPTACLE:
HOUSING = THERMOPLASTIC UL94 V-0
CONTACT = BRASS
SHELL = STAINLESS STEEL

1. FOR APPLICATION USE AND CARE INFORMATION CONSULT VPC USERS GUIDE @ WWW.VPC.COM

NOTES:

CUSTOMER DRAWING



**PCB ADAPTER
VTAC ITA TO DISPLAYPORT**

RELATIVE CONNECTOR POSITIONS AND WIRE ROUTING ARE GENERIC AND MAY VARY WITH PINOUT
DIMENSIONS ARE SHOWN AS:
[MILLIMETERS]
INCHES

DWG. NO.	REV
510171116	B
SCALE	CAGE CODE
3:2	18117
SHEET	1 OF 1