

DO NOT SCALE DRAWING

THE INFORMATION CONTAINED HEREIN IS THE EXCLUSIVE PROPERTY OF VIRGINIA PANEL CORPORATION AND IS SUBMITTED FOR USE BY THE CUSTOMER ONLY. THE DATA SHALL NOT BE DUPLICATED, USED, OR DISCLOSED IN WHOLE OR IN PART FOR ANY PURPOSE OTHER THAN TO MAINTAIN THE EQUIPMENT PROVIDED. CONSULT WITH VIRGINIA PANEL CORPORATION ENGINEERING IF MORE DETAIL IS REQUIRED.

REV	DESCRIPTION	DATE	ENGINEER
C	ECN #13144	1/25/2023	L SALE

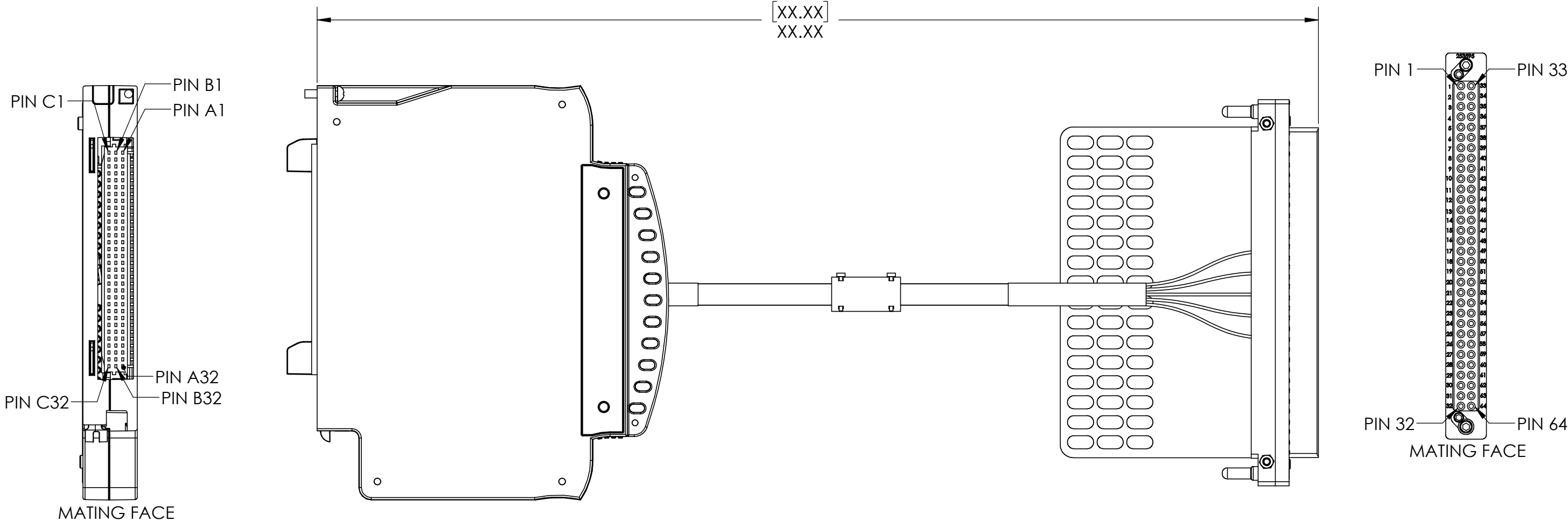

MATING ITA MODULE	510108101 (1)
MATING PATCHCORDS	7-103425000-036 (8)

1. FOR APPLICATION USE AND CARE INFORMATION CONSULT VPC USERS GUIDE @ WWW.VPC.COM

NOTES:

VPC P/N 540325010X01 WHERE X =	LENGTH XX.XX"
1	20.00" [508]
2	36.00" [914]
6	48.00" [1219]
9	60.00" [1524]
5	72.00" [1829]
RELATIVE CONNECTOR POSITIONS AND WIRE ROUTING ARE GENERIC AND MAY VARY WITH PINOUT	
DIMENSIONS ARE SHOWN AS: [MILLIMETERS] INCHES	

CUSTOMER DRAWING



**CBA RCV PX1e-4322
INCL TB-4322**

DWG.NO.	540325010X01	REV	C
SIZE	SCALE	CAGE CODE	SHEET
B	NONE	18117	1 OF 2

Run #	From Location (Conn - Pin)	Contact	Wire AWG	Wire/Patchcord P/N	Wire Color	T/P #	To Location (Conn - Pin)	Signal Desc	Notes
1	J1-1	610110101	24AWG ST/P	7-104425000-XXX	WHT	1	TB-B1	AO_0+	
2	J1-33	610110101			WHT/BLU		TB-B2	AO_0-	
3	J1-2	610110101			SHLD		TB-GND	AO_0_SHLD	ALL SHLDS TIED TOGETHER & TERMINATED TO RING TERMINAL ON TB-4322 GND SCREW
4	J1-3	610110101	24AWG ST/P	7-104425000-XXX	WHT	2	TB-B4	AO_1+	
5	J1-35	610110101			WHT/BLU		TB-B5	AO_1-	
6	J1-34	610110101			SHLD		TB-GND	AO_1_SHLD	ALL SHLDS TIED TOGETHER & TERMINATED TO RING TERMINAL ON TB-4322 GND SCREW
7	J1-4	610110101	24AWG ST/P	7-104425000-XXX	WHT	3	TB-B7	AO_2+	
8	J1-36	610110101			WHT/BLU		TB-B8	AO_2-	
9	J1-5	610110101			SHLD		TB-GND	AO_2_SHLD	ALL SHLDS TIED TOGETHER & TERMINATED TO RING TERMINAL ON TB-4322 GND SCREW
10	J1-6	610110101	24AWG ST/P	7-104425000-XXX	WHT	4	TB-B10	AO_3+	
11	J1-38	610110101			WHT/BLU		TB-B11	AO_3-	
12	J1-37	610110101			SHLD		TB-GND	AO_3_SHLD	ALL SHLDS TIED TOGETHER & TERMINATED TO RING TERMINAL ON TB-4322 GND SCREW
13	J1-7	610110101	24AWG ST/P	7-104425000-XXX	WHT	5	TB-B13	AO_4+	
14	J1-39	610110101			WHT/BLU		TB-B14	AO_4-	
15	J1-8	610110101			SHLD		TB-GND	AO_4_SHLD	ALL SHLDS TIED TOGETHER & TERMINATED TO RING TERMINAL ON TB-4322 GND SCREW
16	J1-9	610110101	24AWG ST/P	7-104425000-XXX	WHT	6	TB-B16	AO_5+	
17	J1-41	610110101			WHT/BLU		TB-B17	AO_5-	
18	J1-40	610110101			SHLD		TB-GND	AO_5_SHLD	ALL SHLDS TIED TOGETHER & TERMINATED TO RING TERMINAL ON TB-4322 GND SCREW
19	J1-10	610110101	24AWG ST/P	7-104425000-XXX	WHT	7	TB-B19	AO_6+	
20	J1-42	610110101			WHT/BLU		TB-B20	AO_6-	
21	J1-11	610110101			SHLD		TB-GND	AO_6_SHLD	ALL SHLDS TIED TOGETHER & TERMINATED TO RING TERMINAL ON TB-4322 GND SCREW
22	J1-12	610110101	24AWG ST/P	7-104425000-XXX	WHT	8	TB-B22	AO_7+	
23	J1-44	610110101			WHT/BLU		TB-B23	AO_7-	
24	J1-43	610110101			SHLD		TB-GND	AO_7_SHLD	ALL SHLDS TIED TOGETHER & TERMINATED TO RING TERMINAL ON TB-4322 GND SCREW

CUSTOMER DRAWING - CUSTOMER DRAWING - CUSTOMER DRAWING

THE INFORMATION CONTAINED HEREIN IS THE EXCLUSIVE PROPERTY OF VIRGINIA PANEL CORPORATION AND IS SUBMITTED FOR USE BY THE CUSTOMER ONLY. THE DATA SHALL NOT BE DUPLICATED, USED, OR DISCLOSED IN WHOLE OR IN PART FOR ANY PURPOSE OTHER THAN TO MAINTAIN THE EQUIPMENT PROVIDED.

DWG.NO.		REV	
540325010X01		C	
SIZE	SCALE	CAGE CODE	SHEET
B	NONE	18117	2 OF 2

DO NOT SCALE DRAWING