

DO NOT SCALE DRAWING

THE INFORMATION CONTAINED HEREIN IS THE EXCLUSIVE PROPERTY OF VIRGINIA PANEL CORPORATION AND IS SUBMITTED FOR USE BY THE CUSTOMER ONLY. THE DATA SHALL NOT BE DUPLICATED, USED, OR DISCLOSED IN WHOLE OR IN PART FOR ANY PURPOSE OTHER THAN TO MAINTAIN THE EQUIPMENT PROVIDED. CONSULT WITH VIRGINIA PANEL CORPORATION ENGINEERING IF MORE DETAIL IS REQUIRED.

REVISIONS			
REV	DESCRIPTION	DATE	ENGR
B	ECN #08-541-0112	12/10/08	G LACONI

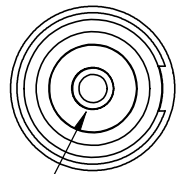

CENTER RECEPTACLE PIN

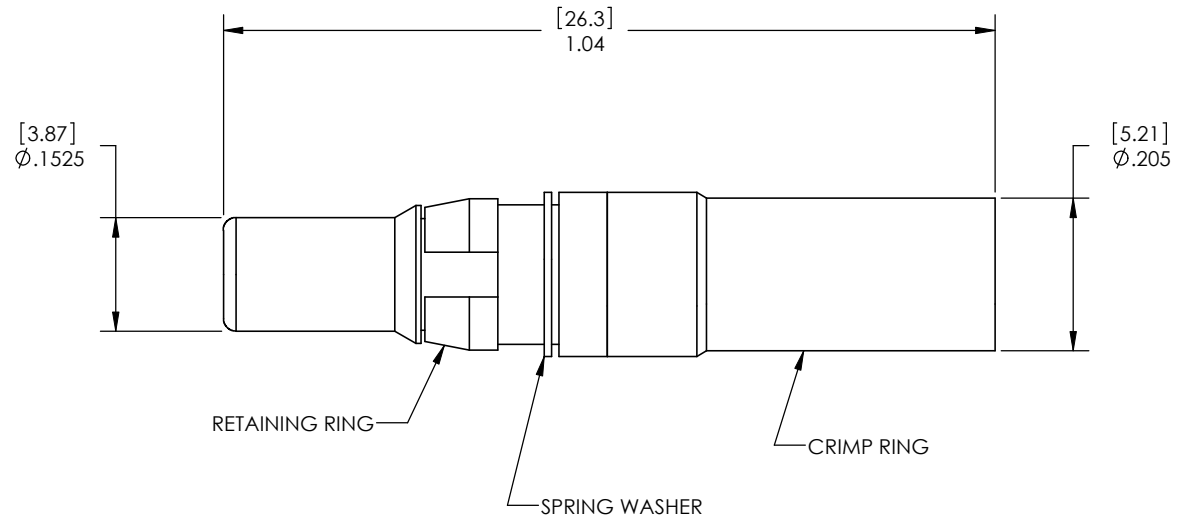

- 5. CHARACTERISTIC IMPEDANCE 75 OHMS
- 4. CRIMP RING AND CENTER PIN SUPPLIED LOOSE
- 3. CRIMP WITH .178 HEX DIE
- 2. FOR USE WITH SUB-MINIATURE RG 59/U COAXIAL CABLE (BELDEN 1855A)

1. FOR APPLICATION USE AND CARE INFORMATION CONSULT VPC USERS GUIDE @ WWW.VPC.COM

NOTES:

CUSTOMER DRAWING

VIRGINIA PANEL CORPORATION
WWW.VPC.COM

CONTACT ITA 75 OHM F/SM RG59u

DIMENSIONS ARE SHOWN AS: [MILLIMETERS] INCHES	SIZE	CAGE CODE	DWG.NO.	REV
	B	18117	610102132	B
SCALE: 4:1		610102132	12/17/2007	SHEET 1 OF 1