

4

3

2

1

DO NOT SCALE DRAWING

THE INFORMATION CONTAINED HEREIN IS THE EXCLUSIVE PROPERTY OF VIRGINIA PANEL CORP. AND IS SUBMITTED FOR USE BY THE CUSTOMER ONLY. THE DATA SHALL NOT BE DUPLICATED, USED, OR DISCLOSED IN WHOLE OR IN PART FOR ANY PURPOSE OTHER THAN TO MAINTAIN THE EQUIPMENT PROVIDED. CONSULT WITH VIRGINIA PANEL CORPORATION ENGINEERING IF MORE DETAIL IS REQUIRED.

REVISIONS				
ZONE	REV	DESCRIPTION	DATE	APPROVED
	C	ECN #4078	6/13/12	RG

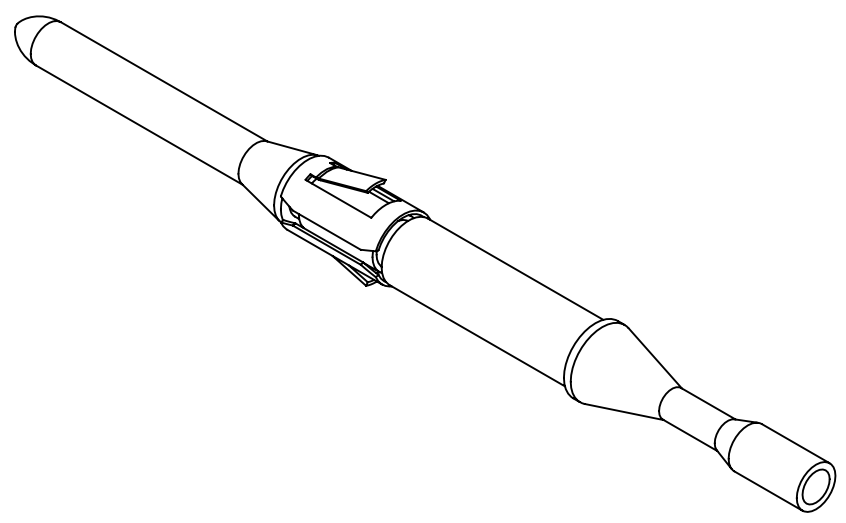

SCALE 5:1

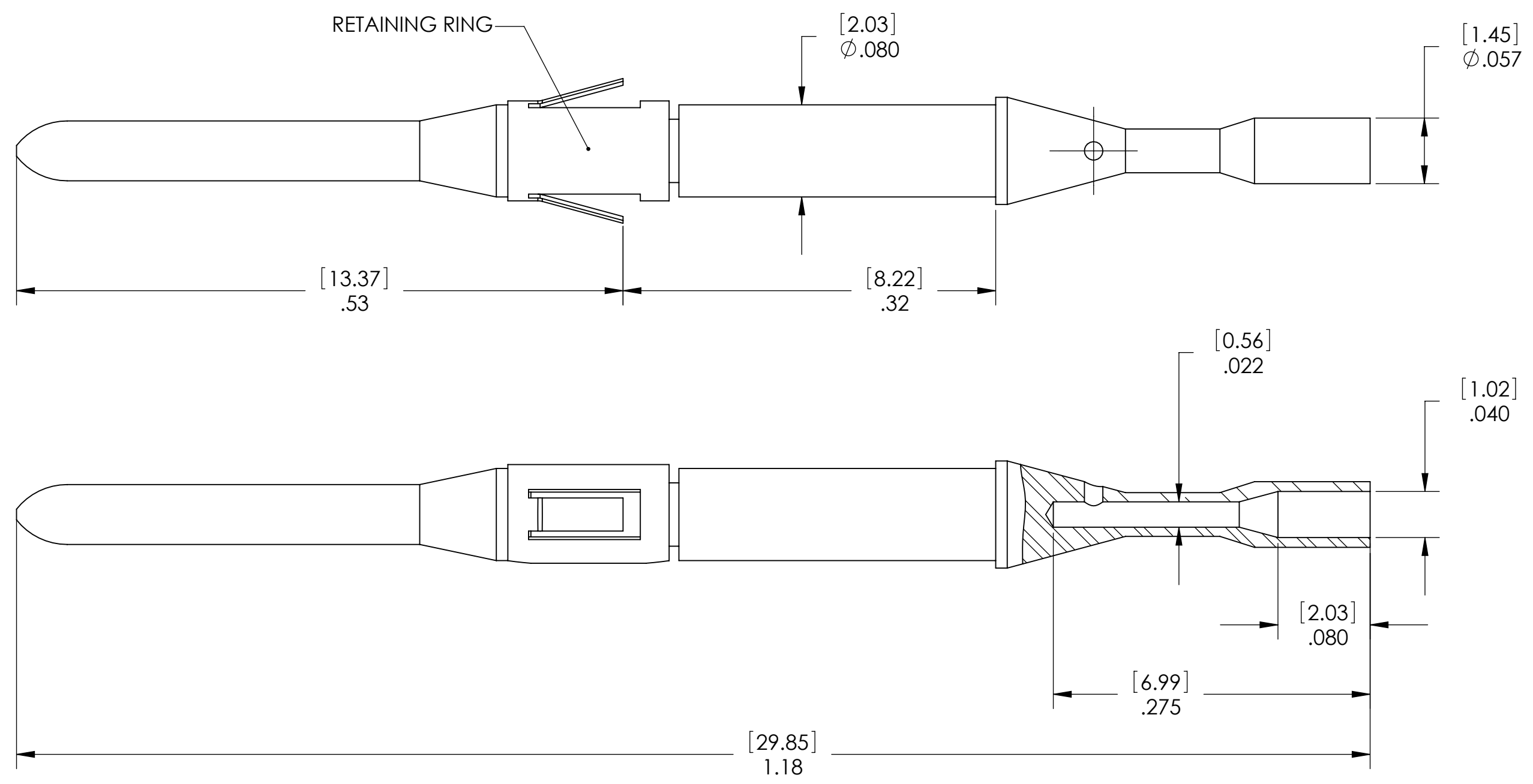

- NOTES:
- 3 FOR CRIMPING INSTRUCTIONS, PLEASE REFER TO VPC USERS MANUAL.
 - 2 CONTACT WEIGHT: .07 GRAMS
 - 1 CONTACT MATERIAL: BRASS; PLATING .000030 Au OVER .0001 Ni
RETAINIG RING MATERIAL - BeCu; PLATING .0001 Ni

CUSTOMER DRAWING - CUSTOMER DRAWING - CUSTOMER DRAWING											
SOLIDWORKS DRAWING FILE	TOLERANCES ON HOLES UNLESS SPECIFIED				DIMENSIONS ARE IN INCHES UNLESS OTHERWISE SPECIFIED.		CONTRACT NO.		SIGNATURES		
	HOLE DIA.		TOLERANCE		TOLERANCES ARE:		DATE		R GARMAN		
	.0135 TO .042		+.003/- .002		DEC.XX±		FRAC±		2/13/03		
	.043 TO .093		+.004/- .002		.XXX±		ANG ±		1°		
	.0935 TO .156		+.005/- .002		REMOVE BURRS. BREAK SHARP EDGES		MATERIAL		DR		
.1562 TO .2656		+.006/- .002						CHK			
.266 TO .4219		+.007/- .002						ENG			
.4375 TO .6094		+.008/- .002						PROD			
.625 TO .75		+.009/- .002						ASSY			
.7656 TO .8437		+.009/- .003						Q A			
.8594 TO 2.000		+.010/- .003						APPD			
VIRGINIA PANEL CORPORATION www.vpc.com								MALE TRIPADDLE CNT, 26-28 AWG		REV C	
SIZE C		FSCM NO. 18117		DWG.NO. 610110169		SCALE: 10:1		2/13/03		SHEET 2 of 2	

4

3

2

1