

4

3

2

1

DO NOT SCALE DRAWING

THE INFORMATION CONTAINED HEREIN IS THE EXCLUSIVE PROPERTY OF VIRGINIA PANEL CORPORATION AND IS SUBMITTED FOR USE BY THE CUSTOMER ONLY. THE DATA SHALL NOT BE DUPLICATED, USED, OR DISCLOSED IN WHOLE OR IN PART FOR ANY PURPOSE OTHER THAN TO MAINTAIN THE EQUIPMENT PROVIDED. CONSULT WITH VIRGINIA PANEL CORPORATION ENGINEERING IF MORE DETAIL IS REQUIRED.

REVISIONS

REV	DESCRIPTION	DATE	ENGR
B	ECN #8104	4/16/18	J SHAND

D

D

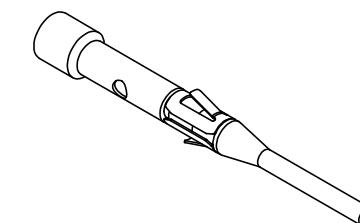

C

C

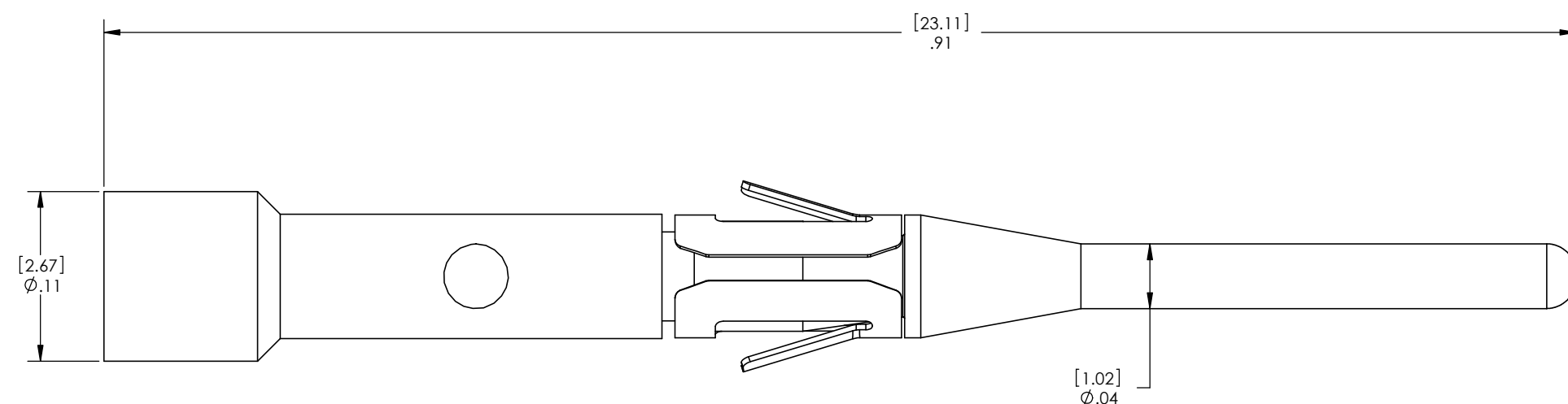

B

B

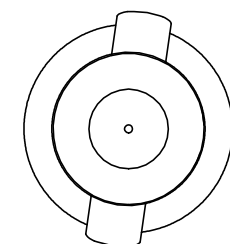

A

A

PART NUMBER	MATERIAL
610113133	CHROMEL
610113134	ALUMEL
610113149	CONSTANTAN
610113169	COPPER
610113160	IRON

CUSTOMER DRAWING

VIRGINIA PANEL CORPORATION  
WWW.VPC.COM

ITA CONTACT ASSM.  
THERMOCOUPLE

1. FOR APPLICATION USE & CARE INFORMATION CONSULT VPC USERS GUIDE @WWW.VPC.COM  
NOTES:

DIMENSIONS ARE SHOWN AS:  
[MILLIMETERS]  
INCHES

SIZE	CAGE CODE	DWG. NO.	REV
C	18117	3455 05 000	B

SCALE: 16:1 345505000 1/16/95 SHEET 1 OF 1

4

3

2

1