

4

3

2

1

DO NOT SCALE DRAWING

THE INFORMATION CONTAINED HEREIN IS THE EXCLUSIVE PROPERTY OF VIRGINIA PANEL CORP. AND IS SUBMITTED FOR USE BY THE CUSTOMER ONLY. THE DATA SHALL NOT BE DUPLICATED, USED, OR DISCLOSED IN WHOLE OR IN PART FOR ANY PURPOSE OTHER THAN TO MAINTAIN THE EQUIPMENT PROVIDED. CONSULT WITH VIRGINIA PANEL CORPORATION ENGINEERING IF MORE DETAIL IS REQUIRED.

REVISIONS				
ZONE	REV	DESCRIPTION	DATE	APPROVED
	A	ORIGINAL RELEASE	5/14/02	
	B	ECN 03-610-0023	7/03/03	AHB
	C	ECN 03-610-0032	12/22/03	AHB
	D	ECN 04-610-001432	12/06/04	DMA

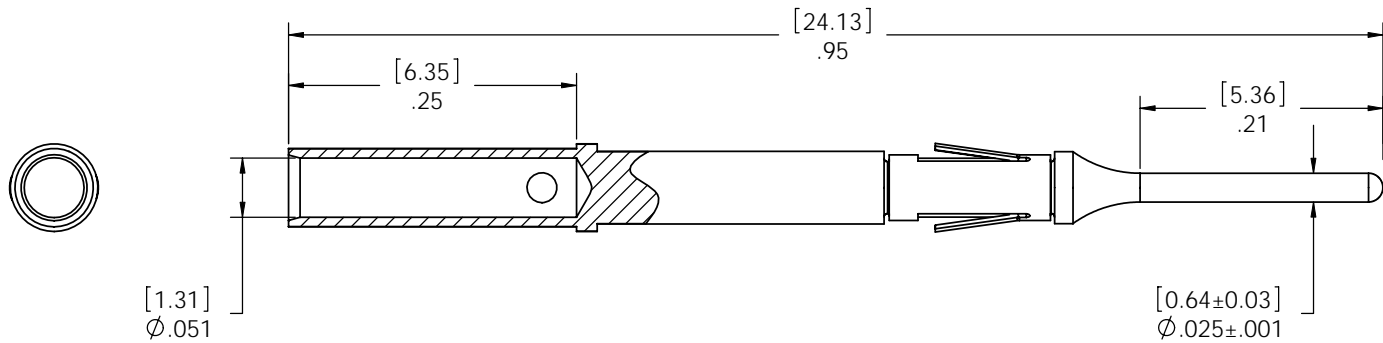
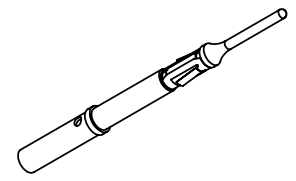

2 PHYSICAL CHARACTERISTICS:
 WEIHTG - .0005 lbs.
 MATERIALS:
 CONTACT - BRASS ALLOY
 RETAINING RING - BeCu ALLOY
 CONTACT PLATING - 30 μ INCHS Au OVER 100 μ INCHES NICKEL

1 FOR APPLICATION, USE & CARE INFORMATION
 CONSULT VPC USERS GUIDE @WWW.VPC.COM

NOTES:

CUSTOMER DRAWING - CUSTOMER DRAWING

SOLIDWORKS DRAWING FILE	DIMENSIONS ARE SHOWN AS: (millimeters) INCHES	SIGNATURES		DATE	VIRGINIA PANEL CORPORATION www.VPC.COM		
		DR	D. Ashby	5/14/02			
	REMOVE BURRS - BREAK SHARP EDGES	CHK			CNT ML OPDL 22-24 Awg CMP ASM & Solderable 22-28 Awg		
	MATERIAL	ENG					
FINISH	PROD			SIZE	FSCM NO.	DWG. NO.	REV
	APPD			C	18117	610138109	D
		SCALE: NONE		5/14/02	610138109	SHEET 1 OF 1	

4

3

2

1