

DO NOT SCALE DRAWING

THE INFORMATION CONTAINED HEREIN IS THE EXCLUSIVE PROPERTY OF VIRGINIA PANEL CORPORATION AND IS SUBMITTED FOR USE BY THE CUSTOMER ONLY. THE DATA SHALL NOT BE DUPLICATED, USED, OR DISCLOSED IN WHOLE OR IN PART FOR ANY PURPOSE OTHER THAN TO MAINTAIN THE EQUIPMENT PROVIDED. CONSULT WITH VIRGINIA PANEL CORPORATION ENGINEERING IF MORE DETAIL IS REQUIRED.

REVISIONS			
REV	DESCRIPTION	DATE	ENGR
C	ECN # 5542	11/7/14	L LOCKRIDGE

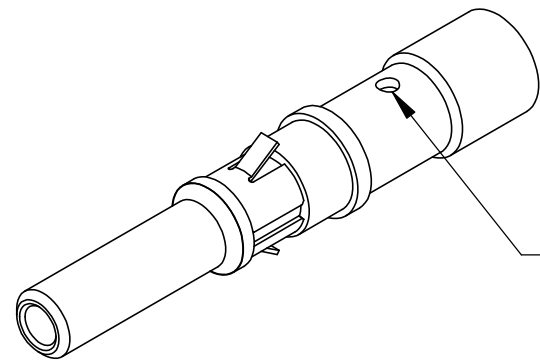

SOLDER HOLE ONE SIDE ONLY

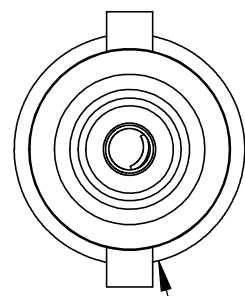

[3.81]
Ø.15

[2.49]
Ø.098

[3.33]
Ø.13

[21.51]
.85

RETAINER RING

SHIELD BODY

CUSTOMER DRAWING

VIRGINIA PANEL CORPORATION

WWW.VPC.COM

CONTACT, ITA, MICRO-COAX
FOR RG 316 DBL. SHLD.

DIMENSIONS ARE SHOWN AS:

[MILLIMETERS]
INCHES

SIZE	CAGE CODE	DWG.NO.	REV
B	18117	610141104	C
SCALE: 8:1	610141104	4/17/2009	SHEET 1 OF 1

- NOTES:
- FOR APPLICATION USE AND CARE INFORMATION CONSULT VPC USERS GUIDE @ WWW.VPC.COM
 - Purchased part shall contain Center Conductor Contact, and Shield Body with Retainer Ring