

4

3

2

1

DO NOT SCALE DRAWING

THE INFORMATION CONTAINED HEREIN IS THE EXCLUSIVE PROPERTY OF VIRGINIA PANEL CORPORATION AND IS SUBMITTED FOR USE BY THE CUSTOMER ONLY. THE DATA SHALL NOT BE DUPLICATED, USED, OR DISCLOSED IN WHOLE OR IN PART FOR ANY PURPOSE OTHER THAN TO MAINTAIN THE EQUIPMENT PROVIDED. CONSULT WITH VIRGINIA PANEL CORPORATION ENGINEERING IF MORE DETAIL IS REQUIRED.

REVISIONS			
REV	DESCRIPTION	DATE	ENGR
A	DRAWING ORIGINATION - ECN #4932	11/20/13	R HERRON

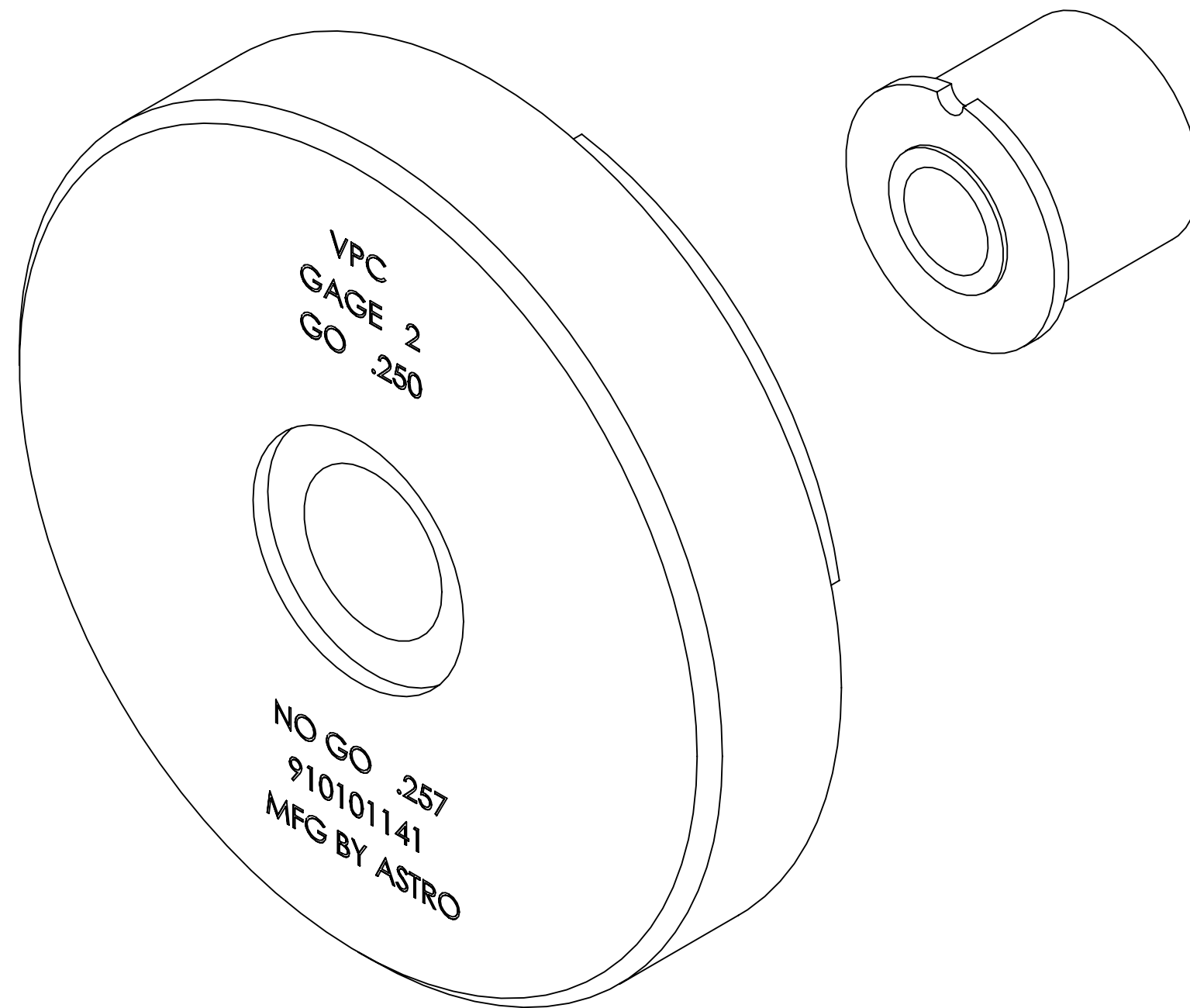

2. FOR USE WITH PNEUMATIC CRIMPER M22520/23-01, VPC P/N 910101140
 1. FOR APPLICATION USE & CARE INFORMATION CONSULT VPC USERS GUIDE @WWW.VPC.COM
 NOTES:

CUSTOMER DRAWING			
VIRGINIA PANEL CORPORATION WWW.VPC.COM			
150 AMP POWER CRIMP ACCESSORY KIT			
DIMENSIONS ARE SHOWN AS:	SIZE	CAGE CODE	DWG. NO.
[MILLIMETERS] INCHES	C	18117	910102117
SCALE: 2:1	910102117	11/20/13	SHEET 1 OF 1

4

3

2

1

D

D

C

C

B

B

A

A