



ASSEMBLY, INSTALLATION, AND REMOVAL OF CONTACTS AND MODULES

FOR 50 OHM COAX CONTACTS AND MODULES

INDEX ([CLICK TO NAVIAGTE TO PAGE](#))

PAGE

RECEIVER CONTACT CRIMP TOOL SETUP, ADJUSTMENT, & ASSEMBLY

1 [PART #610104101 FOR RG316](#)

3 [PART #610104129 FOR RG59](#)

5 [PART #610104131 FOR RG58](#)

7 [RECEIVER CONTACT INSTALLATION & REMOVAL](#)

ITA CONTACT CRIMP TOOL SETUP, ADJUSTMENT, & ASSEMBLY

8 [PART #610103103 FOR RG316](#)

10 [PART #610103132 FOR RG59](#)

12 [PART #610103104 FOR RG58](#)

14 [ITA CONTACT INSTALLATION & REMOVAL](#)

MODULES & SPECIFICATIONS

15 [90 SERIES MODULE INSTALLATION & REMOVAL](#)

16 [CROSS REFERENCE TABLES](#)

17 [CONTACT PERFORMANCE SPECIFICATIONS](#)

18 [VSWR CHART & GRAPH](#)

Please note that any printed or downloaded User Manuals may not reflect the most current revisions. The information contained in these materials is subject to change. For the most current information available, visit vpc.com.

RECEIVER CONTACT CRIMP TOOL SETUP, ADJUSTMENT, & ASSEMBLY

PART # 610104101 for RG316 / 910101102 / 910102102 / 910104119 / 910121104



Dimensions shown: [millimeters]
inches

CRIMP TOOL SETUP

1. Set up the Crimp Tool, Part # 910101102 (**Figure A**), by loosening the latch locking screw (counter-clockwise, until turning stops). Remove any previously used locator.
2. Insert the open end of the Female Signal Contact Locator Die, Part # 910104119 (**Figure B**), into the contact locator retainer.
3. Slide the retaining latch toward the locator until the locator is securely locked into place. The locator may have to be twisted to allow the latch to retain it. Tighten the latch locking screw.

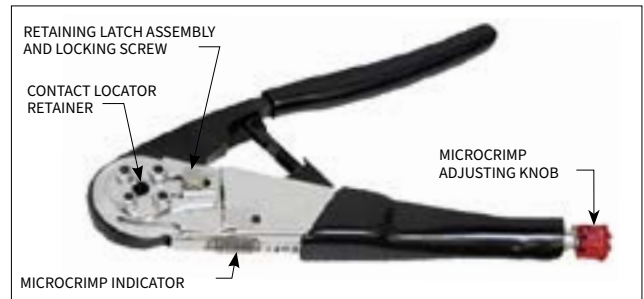

Figure A. MS 31 Crimp Tool, Part # 910101102.

CRIMP TOOL ADJUSTMENT

1. Adjust the crimp tool setting by pulling and turning the microcrimp adjusting knob (clockwise increases, counter-clockwise decreases setting) until the microcrimp indicator reads 0.030". Verify with gauge pin. See calibration instructions for Part # 910101102 for gauge pin verification instructions.



Figure B. Female Signal Contact Locator Die, Part # 910104119.

ASSEMBLY INSTRUCTIONS

1. Slide nut onto wire (**Figure C**).
2. Strip wire and dielectric (**Figure C**).
3. Unravel braid and fold back over outer insulation. Slide follower over dielectric (**Figure D**).
4. Slide rear insulator assembly over conductor wire (**Figure E**) and crimp using the crimp tool and locator die. The back of the center conductor should be butted against the dielectric (**Figure F**). Pull gently on contact to check crimp.

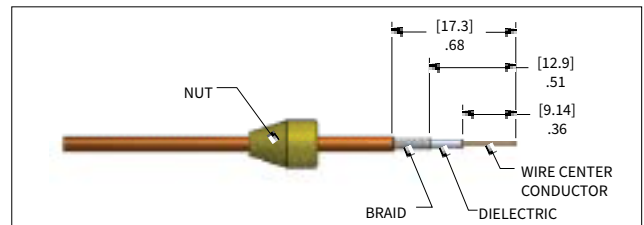

Figure C. Install nut and strip wire.



Figure D. Fold braid back. Install follower.

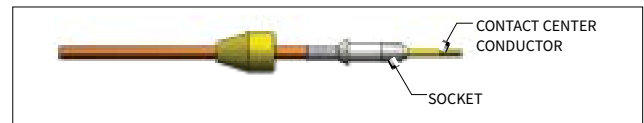

Figure E. Install rear insulator assembly.

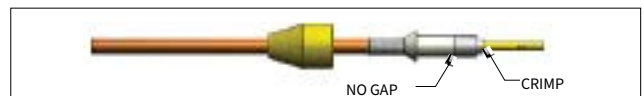

Figure F. Crimp center conductor.

Continued on next page...

[RETURN TO INDEX](#)

RECEIVER CONTACT CRIMP TOOL SETUP, ADJUSTMENT, & ASSEMBLY

PART # 610104101 for RG316 / 610103103 / 910121104

ASSEMBLY INSTRUCTIONS, CONTINUED

5. Slide front insulator over crimped contact until it bottoms out. Turn the braid back toward the shield conductor laying it against the cone on the back of the follower. Trim excess braid flush with the top of the cone. **(Figure G)**.
6. Slide shield conductor over assembly. **(Figure H)**
7. Screw nut onto the back of the shield to complete the assembly **(Figure I)**. The nut must hold a 0.28" [7.11 mm] minimum dimension from the retaining clip, or it will not lock into the module.
8. After assembly, check mating force using a 50 Ohm Coax ITA Contact, Part # 610103103. A mating force greater than 2 lbs [0.91 kg] can cause excessive receiver handle force and ITA bowing. A mating force in excess of 2 lbs [0.91 kg] can be adjusted by using the Shield Conductor Forming Tool, Part # 910121104 **(Figure J)**. Insert the connector so that half of the coax shield slots are still showing and squeeze the tool handle. The tool should be used once each time in three different positions (approx. equally spaced) for best results.

Dimensions shown: [millimeters]
inches

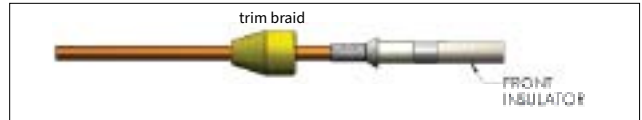

Figure G. Install front insulator and trim braid.



Figure H. Install shield conductor.



Figure I. Screw nut onto shield conductor.



Figure J. Shield Conductor Forming Tool, Part # 910121104.

[RETURN TO INDEX](#)

RECEIVER CONTACT CRIMP TOOL SETUP, ADJUSTMENT, & ASSEMBLY

PART # 610104129 FOR RG59 / 910101102 / 910101108 / 910104119 / 910121104



CRIMP TOOL SETUP

1. Set up the Crimp Tool, Part # 910101102 (**Figure A**), by loosening the latch locking screw (counter-clockwise, until turning stops). Remove any previously used locator.
2. Insert the open end of the Female Signal Contact Locator Die, Part # 910104119 (**Figure B**), into the contact locator retainer.
3. Slide the retaining latch toward the locator until the locator is securely locked into place. The locator may have to be twisted to allow the latch to retain it. Tighten the latch locking screw.

CRIMP TOOL ADJUSTMENT

1. Adjust the crimp tool setting by pulling and turning the microcrimp adjusting knob (clockwise increases, counter-clockwise decreases setting) until the microcrimp indicator reads 0.040". Verify with gauge pin. See calibration instructions for Part # 910101102 for gauge pin verification instructions.

ASSEMBLY INSTRUCTIONS

1. Slide shrink tubing onto wire and strip (**Figure C**).
2. Slide the crimp ring over the braid. Unravel braid and fold back over the crimp ring (**Figure D**).
3. Strip dielectric (**Figure D**).
4. Slide rear insulator and conductor contact assembly over the conductor wire and crimp using the crimp tool and locator die. The back of the center conductor should be flush with the dielectric (**Figure E**).
5. Slide the front insulator over the crimped contact until it stops flush with the rear insulator (**Figure F**).
6. Slide the shield conductor over the center conductor and wire assembly (**Figure G**).

Continued on next page...

Dimensions shown: [millimeters]
inches

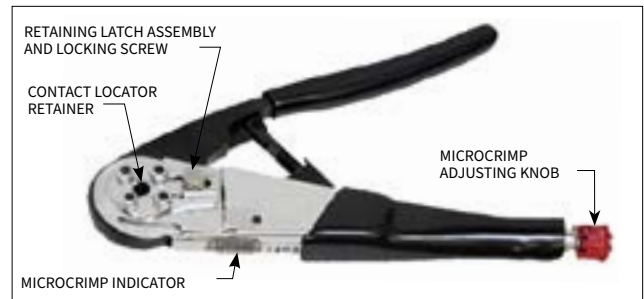

Figure A. MS 31 Crimp Tool, Part # 910101102.



Figure B. Female Signal Contact Locator Die, Part # 910104119.

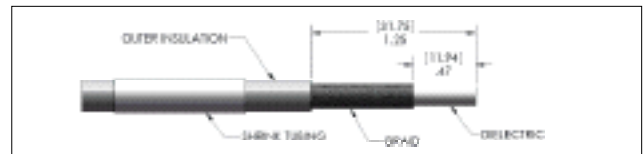

Figure C. Strip wire and install tubing.

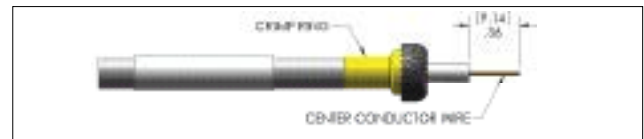

Figure D. Fold braid back and strip dielectric.



Figure E. Make sure there is no gap between the center conductor and the dielectric.

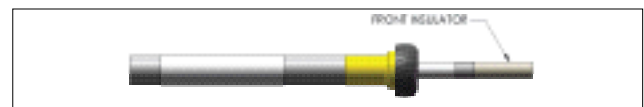

Figure F. Install insulator.

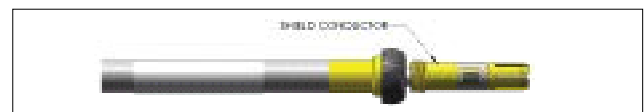

Figure G. Install shield conductor.

[RETURN TO INDEX](#)

RECEIVER CONTACT CRIMP TOOL SETUP, ADJUSTMENT, & ASSEMBLY

PART # 610104129 FOR RG59 / 610103132 / 910101108 / 910121104

ASSEMBLY INSTRUCTIONS, CONTINUED

7. Turn the braid back toward the shield conductor laying it on top of the threaded portion of the shield conductor. No strands of the braid should extend beyond the threaded portion (**Figure H**). Trim braid if necessary.
8. Slide the crimp ring into position over the braid and crimp in two places using Hex Crimp Tool, Part # 910101108. Use the larger die position for crimp position "A" and the smaller die position for crimp position "B". The crimp ring must hold 0.28" [7.11 mm] minimum dimension from the retaining clip or it will not lock into the module (**Figure J**).
9. Slide the shrink tubing over the exposed braid and the "C" position crimp and shrink (**Figure K**).
10. After assembly, check the mating force using a 50 Ohm Coax ITA contact, Part # 610103132. A mating force greater than 2 lbs [0.91 kg] can cause excess receiver handle force and ITA bowing. If the mating force is greater than 2 lbs [0.91 kg] adjust the shield conductor using the Shield Conductor Forming Tool, Part # 910121104 (**Figure L**). Insert the contact so that half of the coax shield slots are still showing and squeeze the tool handle. The tool should be used once each time in three different positions (approx. equally spaced) for best results.

Dimensions shown: [millimeters]
inches



Figure H. Fold braid back over shield conductor.



Figure J. Crimp contact.

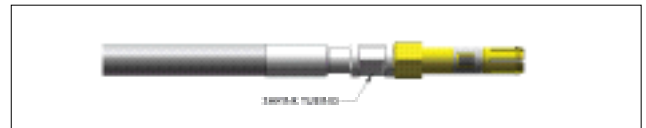

Figure K. Install shrink tubing.



Figure L. Shield Conductor Forming Tool, Part # 910121104.

[RETURN TO INDEX](#)

RECEIVER CONTACT CRIMP TOOL SETUP, ADJUSTMENT, & ASSEMBLY

PART # 610104131 FOR RG58 / 910101102 / 910101108 / 910104119 / 910121104



Dimensions shown: [millimeters]
inches

CRIMP TOOL SETUP

1. Set up the Crimp Tool, Part # 910101102 (**Figure A**), by loosening the latch locking screw (counter-clockwise, until turning stops). Remove any previously used locator.
2. Insert the open end of the Female Signal Contact Locator Die, Part # 910104119 (**Figure B**), into the contact locator retainer.
3. Slide the retaining latch toward the locator until the locator is securely locked into place. The locator may have to be twisted to allow the latch to retain it. Tighten the latch locking screw.

CRIMP TOOL ADJUSTMENT

1. Adjust the crimp tool setting by pulling and turning the microcrimp adjusting knob (clockwise increases, counter-clockwise decreases setting) until the microcrimp indicator reads 0.040". Verify with gauge pin. See calibration instructions for Part # 910101102 for gauge pin verification instructions.

ASSEMBLY INSTRUCTIONS

1. Strip wire (**Figure C**).
2. Slide crimp ring onto wire (**Figure C**).
3. Unravel braid and fold back over outer insulation (**Figure D**). Slide shrink tubing over dielectric (**Figure D**) and shrink.
4. Slide rear insulator over conductor wire (**Figure E**) and crimp using the crimp tool and locator die. The back of the center conductor should be butted against the dielectric (**Figure F**). Pull gently on contact to check crimp.

Continued on next page...

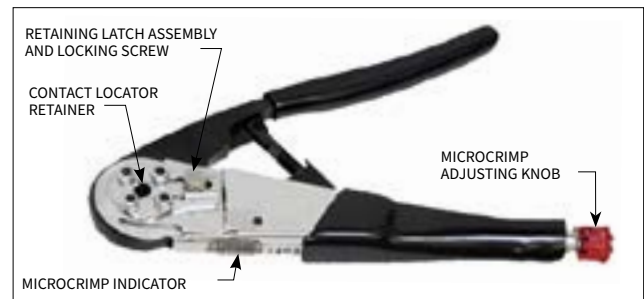

Figure A. MS 31 Crimp Tool, Part # 910101102.



Figure B. Female Signal Contact Locator Die, Part # 910104119.

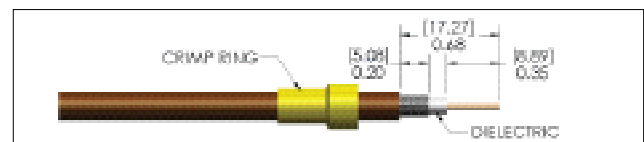

Figure C. Strip wire.

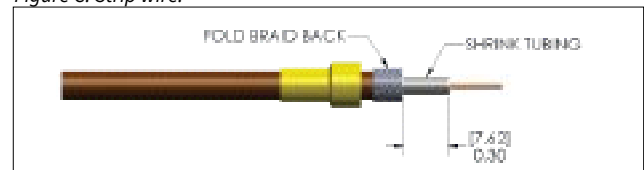

Figure D. Fold braid back and install tubing.

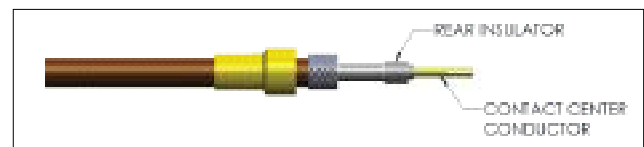

Figure E. Install rear insulator.



Figure F. Make sure there is no gap between the center conductor and the dielectric.

[RETURN TO INDEX](#)

RECEIVER CONTACT CRIMP TOOL SETUP, ADJUSTMENT, & ASSEMBLY

PART # 610104131 FOR RG58 / 610103104 / 910101108 / 910121104

ASSEMBLY INSTRUCTIONS, CONTINUED

5. Slide front insulator over crimped contact until it bottoms (**Figure G**). Slide the shield conductor over the center conductor assembly (**Figure H**).
6. Turn the braid back toward the shield conductor laying it on top of the threaded portion of the shield conductor. No strands of the braid should extend beyond the threaded portion (**Figure J**). Trim braid if necessary.
7. Push crimp ring into position over braid and crimp (**Figure K**) using the Hex Crimp Tool, Part # 910101108. Use the larger die position for crimp position "A" and the smaller die position for crimp position "B". The crimp ring must hold 0.28" [7.11 mm] minimum dimension from retaining clip or it will not lock in the module.
8. After assembly, check mating force using a 50 OHM Coax ITA Contact, Part # 610103104. A mating force greater than 2 lbs [0.91 kg] can cause excessive Receiver handle force and ITA bowing. A mating force in excess of 2 lbs [0.91 kg] can be adjusted by using the Shield Conductor Forming Tool, Part # 910121104 (**Figure L**). Insert the connector so that half of the coax shield slots are still showing and squeeze the tool handle. The tool should be used once each time in three different positions (approx. equally spaced) for best results.

Dimensions shown: [millimeters]
inches



Figure G. Install front insulator.



Figure H. Install shield conductor.



Figure J. Fold braid over shield conductor.

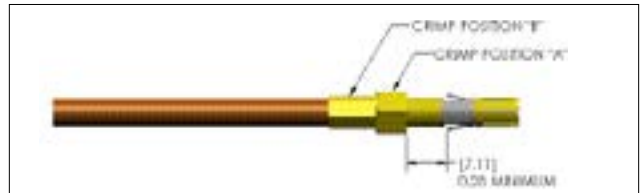

Figure K. Crimp contact.



Figure L. Shield Conductor Forming Tool, Part # 910121104.

[RETURN TO INDEX](#)

RECEIVER CONTACT INSTALLATION AND REMOVAL

PART # 610104101 / 610104129 / 610104131 / 910112101

CONTACT INSTALLATION INSTRUCTIONS

1. Assemble the contact to the respective wire.
NOTE: For more information concerning the process of crimping the contact please see contact assembly instructions in this User Manual.
2. Insert the terminated contact into the back (wiring side) of the assembled module. The contact can only go into one side. Once in place, pull the wire slightly to ensure that the contact is seated.

CONTACT REMOVAL INSTRUCTIONS

1. Remove the module from the receiver frame.
NOTE: For more information concerning the process of removing the module from the receiver frame, see module installation and removal instructions in this User Manual.
2. Place the Power/Coax Receiver Extraction Tool, Part # 910112101 (**Figure A**), over the contact to be removed/replaced. Use care to keep the tool perpendicular to the surface of the module, otherwise the tool or the contact could be bent.
3. Once the extraction tool is seated and the retaining ring tabs on the contact are compressed, push the tool into the module (**Figure B**). The contact will be pushed out of the rear of the module.

DO NOT DEPRESS THE PLUNGER ON THE BACK OF THE EXTRACTION TOOL UNTIL THE TIP OF THE EXTRACTION TOOL HAS FULLY SEATED INTO THE MODULE AND COMPRESSED THE RETAINING RING TABS ON THE CONTACT.

NOTE: The process shown here uses standard/90 series modules. The same process is used for modules from other series.



NOTE: If you are using a hybrid module, you may need to reference the User Manual for the other contact type for extraction instructions.



Figure A. Power/Coax Receiver Extraction Tool, Part # 910112101.

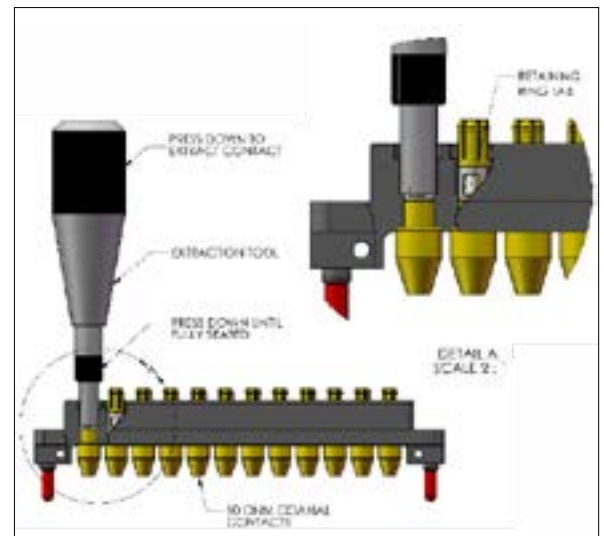

Figure B. Take care to keep the tool perpendicular to prevent bent pins.

[RETURN TO INDEX](#)

ITA CONTACT CRIMP TOOL SETUP, ADJUSTMENT, & ASSEMBLY

PART # 610103103 FOR RG316 / 910101102 / 910101104 / 910102102 / 910104117 / 910113101



Dimensions shown: [millimeters]
inches

TOOLS REQUIRED

Coax 50 OHM Receiver and ITA Crimp Tool Kit, Part # 910102102

- Contains:
- MS 31 Crimp Tool, Part # 910101102
 - Male Signal Contact Locator Die, Part # 910104117
 - Insulator Insertion Tool, Part # 910113101
 - Hex Crimp Tool, Part # 910101104

CRIMP TOOL SETUP

1. Set up the Crimp Tool, Part # 910101102 (**Figure A**), by loosening the latch locking screw (counter-clockwise, until turning stops). Remove any previously used locator.
2. Insert the open end of the Male Signal Contact Locator Die, Part # 910104117 (**Figure B**), into the contact locator retainer.
3. Slide the retaining latch toward the locator until the locator is securely locked into place. The locator may have to be twisted to allow the latch to retain it. Tighten the latch locking screw.

CRIMP TOOL ADJUSTMENT

1. Adjust the crimp tool setting by pulling and turning the microcrimp adjusting knob (clockwise increases, counter-clockwise decreases setting) until the microcrimp indicator reads 0.030". Verify with gauge pin. See calibration instructions for Part # 910101102 for gauge pin verification instructions.

ASSEMBLY INSTRUCTIONS

1. Slide crimp ring and shield conductor onto wire (**Figure C**).
2. Strip wire (**Figure C**).
3. Unravel braid and fold back over outer insulation (**Figure D**).
4. Slide rear insulator over dielectric until it stops against the braid (**Figure D**).
5. Slide the front insulator with contact center conductor over the center conductor wire (**Figure E**) and crimp using the crimp tool and locator die.
6. Slide rear insulator forward pressing it on front insulator until parts are firmly together (**Figure F**).
7. Fold braid back toward the contact center conductor (**Figure F**).

Continued on next page...

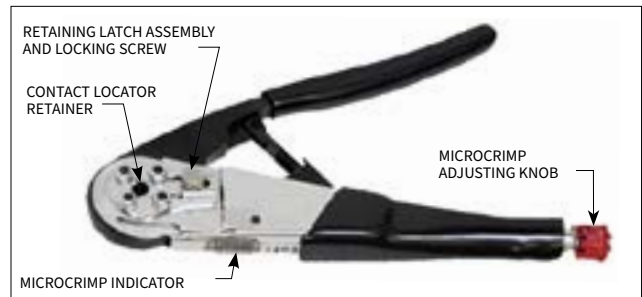

Figure A. MS 31 Crimp Tool, Part # 910101102.



Figure B. Male Signal Contact Locator Die, Part # 910104117.

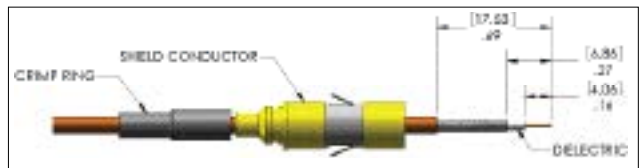

Figure C. Install crimp ring and shield conductor.



Figure D. Fold braid back and install rear insulator.



Figure E. Install front insulator with signal contact.



Figure F. Make sure there is no gap between the rear and front insulator.

[RETURN TO INDEX](#)

ITA CONTACT CRIMP TOOL SETUP, ADJUSTMENT, & ASSEMBLY

PART # 610103103 FOR RG316 / 910113101 / 910101104

ASSEMBLY INSTRUCTIONS, CONTINUED

8. Slide the shield conductor forward over the braid far enough that the braid can be pulled out from under the shield conductor.
9. Using the Insulator Insertion Tool, Part # 910113101 (**Figure G**), press the insulator into the shield conductor until Surface "A" of the tool touches Surface "B" of the shield conductor (**Figure H**).
10. Fold the braid over the shield conductor (**Figure J**).
11. Slide the crimp ring into position over the braid and crimp in two places (**Figure K**) using Hex Crimp Tool, Part # 910101104 (**Figure L**). Position A should be used for the larger portion of the crimp ring and Position C should be used for the smaller portion of the crimp ring.

Dimensions shown: [millimeters]
inches



Figure G. Insulator Insertion Tool, Part # 910113101.



Figure H. Insulator insertion.



Figure J. Fold braid back over shield conductor.



Figure K. Crimp contact.



Figure L. Hex Crimp Tool, Part # 910101104.

[RETURN TO INDEX](#)

ITA CONTACT CRIMP TOOL SETUP, ADJUSTMENT, & ASSEMBLY

PART # 610103132 FOR RG59 / 910101102 / 910101113 / 910102103 / 910104117



CRIMP TOOL SETUP

1. Set up the Crimp Tool, Part # 910101102 (**Figure A**), by loosening the latch locking screw (counter-clockwise, until turning stops). Remove any previously used locator.
2. Insert the open end of the Male Signal Contact Locator Die, Part # 910104117 (**Figure B**), into the contact locator retainer.
3. Slide the retaining latch toward the locator until the locator is securely locked into place. The locator may have to be twisted to allow the latch to retain it. Tighten the latch locking screw.

CRIMP TOOL ADJUSTMENT

1. Adjust the crimp tool setting by pulling and turning the microcrimp adjusting knob (clockwise increases, counter-clockwise decreases setting) until the microcrimp indicator reads 0.040". Verify with gauge pin. See calibration instructions for Part # 910101102 for gauge pin verification instructions.

ASSEMBLY INSTRUCTIONS

1. Cut 2.50" [14.2 mm] length of 0.375" [9.5 mm] diameter shrink tubing.
2. Slide shrink tubing and crimp ring on the wire (**Figure C**).
3. Strip outer insulation (**Figure C**).
4. Unravel braid and fold back over outer insulation (**Figure D**).
5. Slide shield conductor and rear insulator over the dielectric (**Figure D**).
6. Strip dielectric (**Figure D**).
7. Slide the front insulator with signal contact over the conductor wire and crimp (**Figure E**) using the crimp tool and locator die.
8. Slide the rear insulator forward pressing it into the front insulator until parts are firmly together (**Figure F**).

Continued on next page...

Dimensions shown: [millimeters]
inches

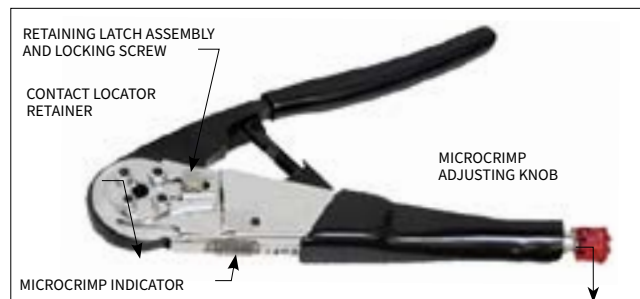

Figure A. MS 31 Crimp Tool, Part # 910101102.



Figure B. Male Signal Contact Locator Die, Part # 910104117.

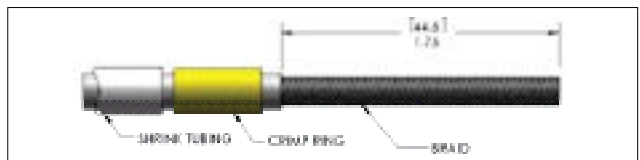

Figure C. Strip wire.

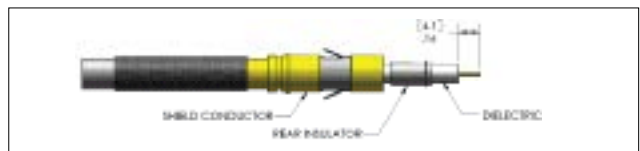

Figure D. Fold braid back and install shield conductor and rear insulator.



Figure E. Install and crimp center conductor assembly.



Figure F. Make sure there is no gap between the front and rear insulators.

[RETURN TO INDEX](#)

ITA CONTACT CRIMP TOOL SETUP, ADJUSTMENT, & ASSEMBLY

PART # 610103132 FOR RG59 / 910101113 / 910113101

Dimensions shown: [millimeters]
inches

ASSEMBLY INSTRUCTIONS, CONTINUED

9. Using the Insulator Insertion Tool, Part # 910113101 (**Figure G**), press the insulator into the shield conductor until Surface "A" of the tool touches Surface "B" of the shield conductor (**Figure H**).
10. Turn braid over the back of the shield conductor (**Figure J**). Trim the braid so that at least 0.10" [2.54 mm] of the first step of the shield conductor is covered.
11. Slide the crimp ring into position over the braid and crimp using Hex Crimp Die, Part # 910101113 (**Figure K**) in Hex position "A" (**Figure L**).
12. Slide the shrink tubing over the exposed braid and crimp ring and shrink (**Figure M**).



Figure G. Insulator Insertion Tool, Part # 910113101.

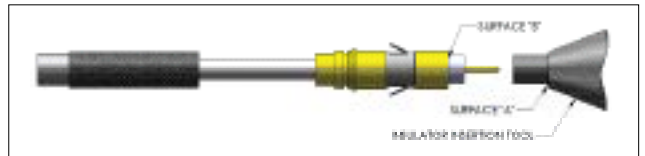

Figure H. Insulator insertion.

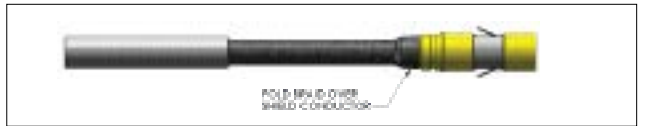

Figure J. Fold braid over shield conductor.



Figure K. Hex Crimp Die, Part # 910101113.



Figure L. Crimp contact.

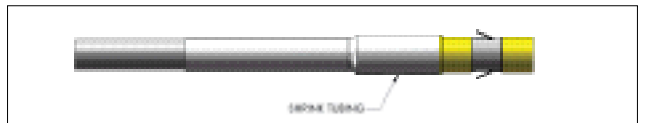

Figure M. Install shrink tubing.

[RETURN TO INDEX](#)

ITA CONTACT CRIMP TOOL SETUP, ADJUSTMENT, & ASSEMBLY

PART # 610103104 FOR RG58 / 910101102 / 910101104 / 910102103 / 910104117 / 910113101



CRIMP TOOL SETUP

1. Set up the Crimp Tool, Part # 910101102 (**Figure A**), by loosening the latch locking screw (counter-clockwise, until turning stops). Remove any previously used locator.
2. Insert the open end of the Male Signal Contact Locator Die, Part # 910104117 (**Figure B**), into the contact locator retainer.
3. Slide the retaining latch toward the locator until the locator is securely locked into place. The locator may have to be twisted to allow the latch to retain it. Tighten the latch locking screw.

Dimensions shown: [millimeters]
inches

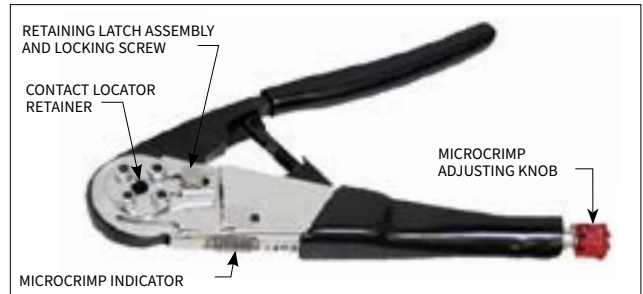

Figure A. MS 31 Crimp Tool, Part # 910101102.

CRIMP TOOL ADJUSTMENT

1. Adjust the crimp tool setting by pulling and turning the microcrimp adjusting knob (clockwise increases, counter-clockwise decreases setting) until the microcrimp indicator reads 0.040". Verify with gauge pin. See calibration instructions for Part # 910101102 for gauge pin verification instructions.

ASSEMBLY INSTRUCTIONS

1. Strip wire (**Figure C**).
2. Slide tubing and crimp ring on wire (**Figure C**).
3. Unravel braid and fold back over crimp ring (**Figure D**).
4. Strip dielectric (**Figure D**).
5. Slide shield conductor and rear insulator over the dielectric (**Figure E**).
6. Slide front insulator with contact center conductor over the conductor wire (**Figure F**) and crimp using the crimp tool and locator die.
7. Slide rear insulator forward pressing it on front insulator until parts are firmly together (**Figure G**).

Continued on next page...



Figure B. Male Signal Contact Locator Die, Part # 910104117.

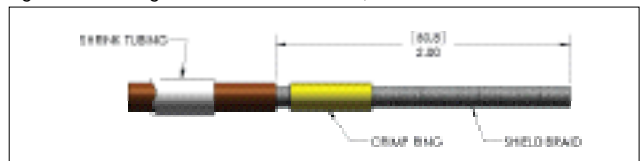

Figure C. Strip wire and install tubing.



Figure D. Fold braid back and strip dielectric.



Figure E. Install shield conductor and rear insulator.



Figure F. Install front insulator with contact center conductor.



Figure G. Make sure there is no gap between the front and rear insulator.

[RETURN TO INDEX](#)

ITA CONTACT CRIMP TOOL SETUP, ADJUSTMENT, & ASSEMBLY

PART # 610103104 FOR RG58 / 910101104 / 910113101

ASSEMBLY INSTRUCTIONS, CONTINUED

8. Using the Insulator Insertion Tool, Part # 910113101 (**Figure H**), press the insulator into the shield conductor until Surface "A" of the tool touches Surface "B" of the shield conductor (**Figure J**).
9. Fold braid back over the shield conductor (**Figure K**). Trim braid so that a minimum of 0.10" [2.54 mm] covers the first step of the shield conductor.
10. Slide the crimp ring into position over braid and crimp using Hex Crimp Tool, Part # 910101104 (**Figure L**) in position "A" for the first crimp, rotate the hex 180° and crimp in the same position using position "B" (**Figure M**).
11. Slide the shrink tubing over the exposed braid and crimp ring and shrink (**Figure N**).

Dimensions shown: [millimeters]
inches



Figure H. Insulator Insertion Tool, Part # 910113101.

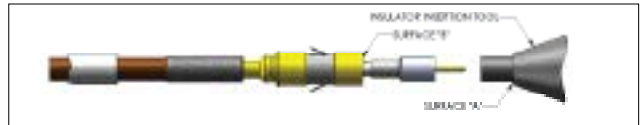

Figure J. Insulator insertion.



Figure K. Fold braid back over shield conductor.



Figure L. Hex Crimp Tool, Part # 910101104.



Figure M. Crimp contact.

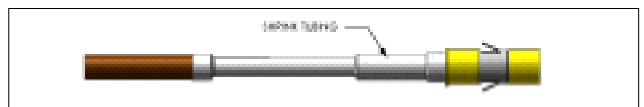

Figure N. Install shrink tubing.

[RETURN TO INDEX](#)

ITA CONTACT INSTALLATION AND REMOVAL

PART # 610103103 / 610103104 / 610103132 / 910112105

CONTACT INSTALLATION INSTRUCTIONS

1. Assemble the contact to the respective wire.
NOTE: For more information concerning the process of crimping the contact please see contact assembly instructions in this User Manual.
2. Insert the terminated contact into the back (wiring side) of the module. Push the contact forward until the crimp is inside the module housing. Once in place, pull the wire slightly to ensure the contact is seated.

CONTACT REMOVAL INSTRUCTIONS

1. Remove the module from the ITA frame.
NOTE: For more information concerning the process of removing the module from the ITA frame, see module installation and removal instructions in this User Manual.
2. Place the Power/Coax ITA Extraction Tool, Part # 910112105 (**Figure A**), over the contact to be removed/replaced. Use care to keep the tool perpendicular to the surface of the module as not to bend the tool or the contact to be removed. Rotate the tool slightly while pushing it into the counter bore on the mating side of the module.
3. Once the extraction tool is seated properly and the retaining ring tabs on the contact are compressed, push the tool into the module (**Figure B**). The contact will be pushed out of the rear of the module.

DO NOT DEPRESS THE PLUNGER ON THE BACK OF THE EXTRACTION TOOL UNTIL THE TIP OF THE EXTRACTION TOOL HAS FULLY SEATED INTO THE MODULE AND COMPRESSED THE RETAINING RING TABS ON THE CONTACT.

NOTE: The process shown here uses standard/90 series modules. The same process is used for modules from other series.



NOTE: If you are using a hybrid module, you may need to reference the User Manual for the other contact type for extraction instructions.

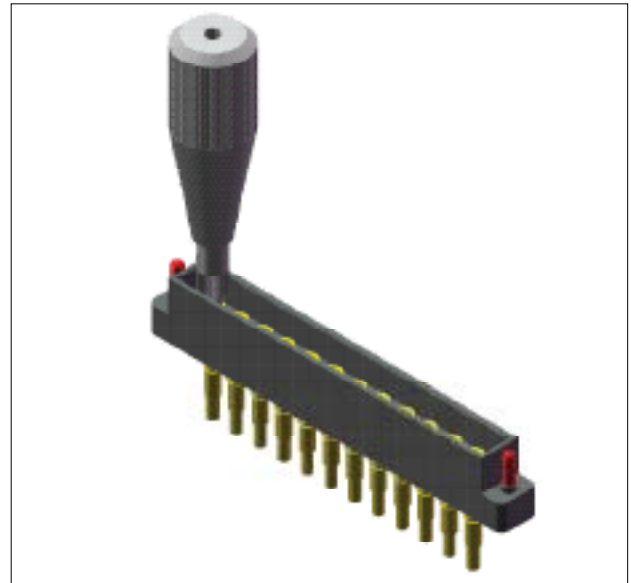

Figure A. Power/Coax ITA Extraction Tool, Part # 910112105.

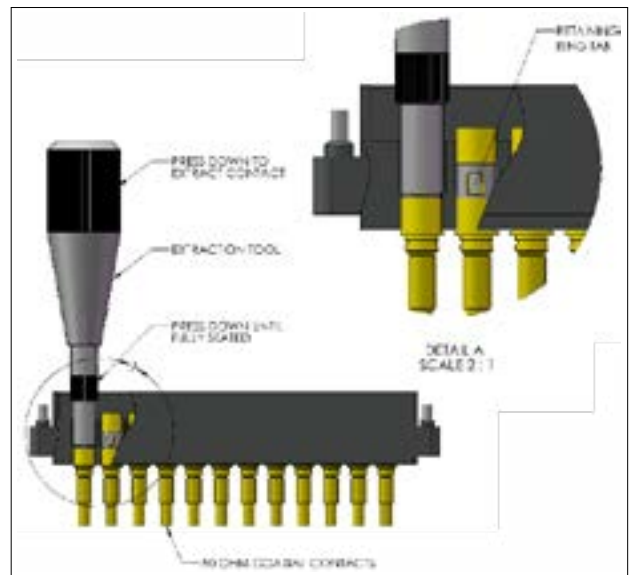

Figure B. Take care to keep the tool perpendicular so as to not bend the pins.

[RETURN TO INDEX](#)

90 SERIES MODULE INSTALLATION AND REMOVAL

RECEIVER PART # 510104102

ITA PART # 510108102

TOOLS REQUIRED

$\frac{3}{32}$ Allen Wrench

INSTALLATION INSTRUCTIONS

1. Place the module in the receiver or ITA until the upper and lower module screws touch the mating holes in the inner frame. Ensure that Position 1 is located at the top for systems in which the modules are oriented vertically or to the left for systems in which the modules are oriented horizontally.
2. Using a $\frac{3}{32}$ Allen wrench, tighten the top screw 1 to 2 full revolutions, while pushing lightly against the face of the module.
3. Maintain this pressure while tightening the bottom screw 1 to 2 full revolutions.
4. Repeat this sequence until the module is seated. Torque the screw to 4 in-lbs [0.45 Nm].

REMOVAL INSTRUCTIONS

1. To remove, loosen the top screw 1 to 2 full revolutions. Loosen bottom screw 1 to 2 full revolutions.
2. Repeat this sequence until the module is separated from the receiver or ITA.

Note: For optimum performance and system longevity, distribute the contact load evenly throughout the module.

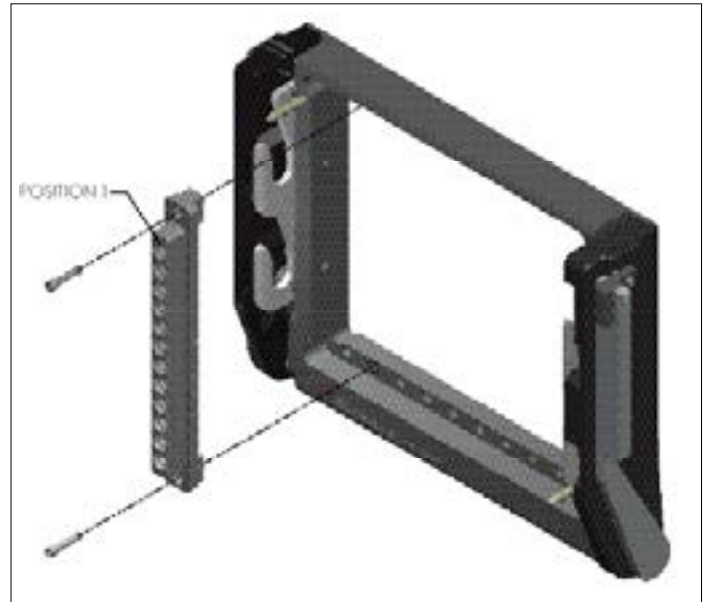

Figure A. Receiver Module.

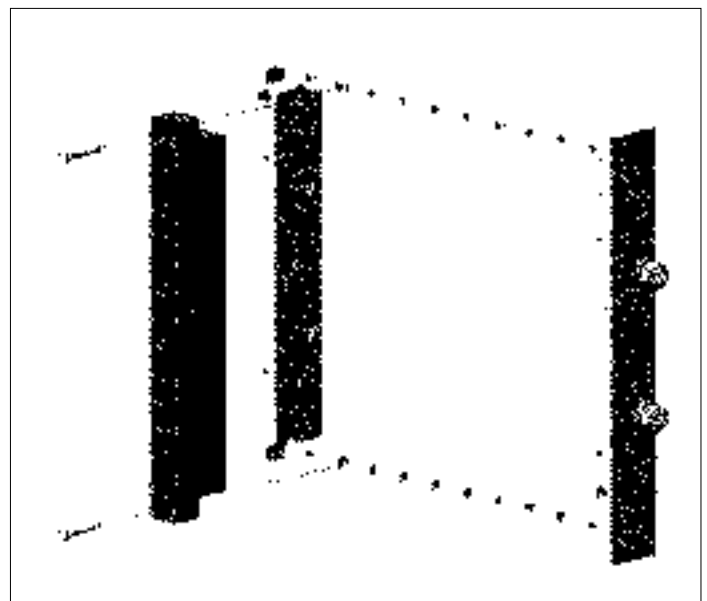

Figure B. ITA Module.

[RETURN TO INDEX](#)

CROSS REFERENCE TABLES

	STANDARD/ 90 SERIES RECEIVER MODULE	CRIMP TOOLS		EXTRACTION
	510104102	910102102	910102103	910112101
RECEIVER CONTACTS				
610104101	X	X		X
610104129	X		X	X
610104131	X		X	X

	STANDARD/ 90 SERIES ITA MODULES	CRIMP TOOLS			EXTRACTION
	510108102	910102102	910102103	910104117	910112105
ITA CONTACTS					
610103103	X	X		X	X
610103104	X		X		X
610103132	X		X		X

[RETURN TO INDEX](#)

CONTACT PERFORMANCE SPECIFICATIONS

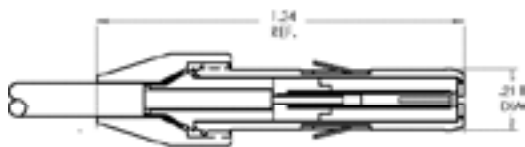

Receiver Contact
Part # 610104101

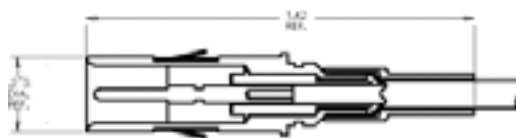

ITA Contact
Part # 610103103

Dimensions shown: [millimeters]
inches

Electrical Specifications

IMPEDANCE	50 Ohms
FREQUENCY RANGE	0 - 2 GHz
CONTACT RESISTANCE	6 Milliohms
CURRENT RATING	1.5 Amp max.
DIELECTRIC BREAKDOWN	1000 V DC
VSWR	Less than or equal to 1.10 : 1 @ 250 MHz
CROSSTALK	Down 90 dB @ 100 MHz
INSERTION LOSS	Less than 0.017 dB @ 100 MHz
RECOMMENDED CABLE	RG316 for 610104101 and 610103103 RG59 for 610104129 and 610103132 Rg58 for 610104131 and 610103104

Mechanical Characteristics

CYCLE LIFE	20,000
MATING FORCE	1.5 lbs [0.68 kg]

Materials and Plating

SHIELD (ITA)	360 Brass alloy per QQ-B-626 .000050 Au per MIL-G-45204, Type II, over 0.0001 Ni per QQ-N-290
SHIELD (RCVR)	360 Brass alloy per QQ-B-626 .000030 Au per MIL-G-45204, Type II, over 0.0001 Ni per QQ-N-290
CENTER CONDUCTOR (ITA)	360 Brass alloy per QQ-B-626 .000060 Au per MIL-G-45204, Type II, over 0.0001 Ni per QQ-N-290
CENTER CONDUCTOR (RCVR)	BeCu alloy M25 .000060 Au per MIL-G-45204, Type II, over 0.0001 Ni per QQ-N-290
CRIMP RING	360 Brass alloy per QQ-B-626 .0001 Ni per QQ-N-290
RETAINING RING	BeCu alloy M25 .0001 Ni per QQ-N-290
NUT	Brass .0000050 Au per MIL-G-45204, Type II, over 0.0001 Ni per QQ-N-290
DIELECTRIC	High Density Polyethylene

[RETURN TO INDEX](#)

VSWR CHART & DIAGRAM

VSWR		
MARKER	FREQUENCY	INSERTION LOSS
1	100 MHz	1.042
2	150 MHz	1.051
3	200 MHz	1.066
4	250 MHz	1.091

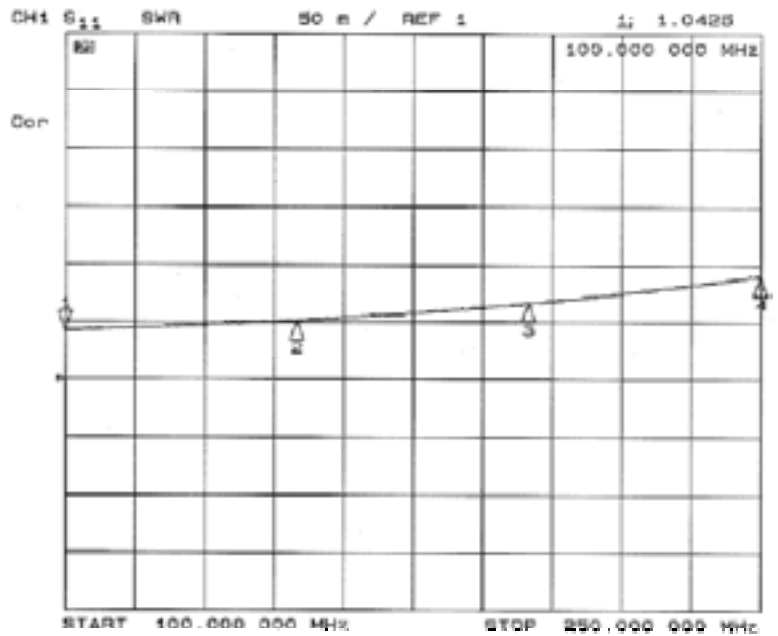

50 Ohm Coax Plots for 610103103 with 610104101

[RETURN TO INDEX](#)