



ASSEMBLY, INSTALLATION & REMOVAL OF CONTACTS AND MODULES

QUADRAPADDLE™

INDEX ([CLICK TO NAVIGATE TO PAGE](#))

PAGE

RECEIVER

- 1 [CONTACT ASSEMBLY](#)
- 2 [CONTACT INSTALLATION & REMOVAL](#)
- 3 [TWIN FEMALE CONTACT REPLACEMENT](#)
- 4 [PCB ADAPTER INSTALLATION & REMOVAL](#)
- 6 [CUSTOM PCB ASSEMBLY INSTALLATION & REMOVAL](#)

ITA

- 8 [CONTACT ASSEMBLY](#)
- 9 [CONTACT INSTALLATION & REMOVAL](#)
- 10 [WIRE WRAP CONTACT INSTALLATION & REMOVAL](#)
- 11 [PCB CONTACT INSTALLATION & REMOVAL](#)
- 12 [PCB ADAPTER INSTALLATION & REMOVAL](#)
- 13 [CUSTOM PCB ASSEMBLY INSTALLATION & REMOVAL](#)

MODULES

- 15 [WIRE WRAP CONTACT TERMINATION](#)
- 16 [MODULE INSTALLATION AND REMOVAL- 90 SERIES](#)
- 17 [MODULE INSTALLATION AND REMOVAL- ICON SERIES](#)
- 18 [TWIN FEMALE/TWIN MALE MODULE TO PCB LAYOUT & MOUNTING](#)
- 20 [CROSS REFERENCE TABLES](#)

*Please note that any printed or downloaded User Manual may not reflect the most current revisions.
The information contained herein is subject to change.
For the most current information available, visit vpc.com.*

CONTACT ASSEMBLY- RECEIVER

PART # 610138116, 610138216, 910101125

CRIMP TOOL SETUP

1. To open the tool (**Figure A**), with the wire gauge numbers facing the user, squeeze the tool handles together to release the ratchet.
2. Place the contact into the correct crimp nest based on wire AWG (**Figure B**), from the front side of the tool.

Dimensions shown: [millimeters]
inches



Figure A. Crimp Tool, (p/n 910101125).

CONTACT ASSEMBLY

1. Determine the strip length according to wire AWG (**Table 1**). Strip wire (**Figure C**).
2. Insert the wire into contact until it stops against the insulation stop.
3. Holding the wire in place, squeeze the crimp tool handles together until the tool is completely closed. Continue squeezing until the last click to allow the handle to release fully.
4. Remove the contact from the crimper (**Figure D**). The conductor should be visible on both ends of the conductor crimp. The insulation crimp should grip securely around the wire insulation without deforming the insulation.
5. Check to make sure the wire meets the minimum pullout force (**Table 1**) and the wire and insulation barrel are within the height and width specifications.
6. Measure the crimp height with a point micrometer.

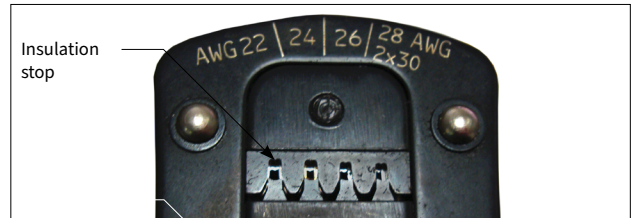

Figure B. Insulation stop on crimp tool.



Figure C. Correctly stripped wire.

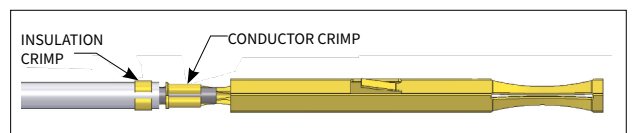

Figure D. Correctly crimped contact.

Table 1.

WIRE SIZE, AWG	CRIMP TOOL	LOCATOR DIE	STRIP LENGTH IN [MM]	INSULATION DIAMETER MAX (IN [MM])	WIRE BARREL CRIMP MAX (IN [MM])	PULLOUT FORCE (LBS [N])	EXTRACTION TOOL
22	910101125	N/A	0.125 [3.18]	0.048 [1.22]	0.032 - 0.038 [0.81 - 0.96]	10 [44.5]	91010112
24					0.027 - 0.036 [0.68 - 0.91]	8 [35.6]	
26				0.025 - 0.032 [0.63 - 0.81]	4 [17.8]		
28				0.024 - 0.030 [0.60 - 0.76]	2 [8.9]		
2-30*				1 [4.4]*			

*Pullout force is for individual wires.

CONTACT INSTALLATION AND REMOVAL- RECEIVER

PART # 610138116, 610138216, 910110112

TOOLS REQUIRED

Phillips Screwdriver
Flat Head Screwdriver

INSTALLATION

1. Assemble the contact to the respective wire.
2. Insert the assembled contact into the back (wiring side) of the assembled module (**Figure A**). The contact will only install from one side of the module. Once installed, pull the wire slightly to ensure that the contact is properly seated. Never use force to install.

REMOVAL

1. Remove the module from the receiver frame.
2. Use a Phillips head screwdriver to remove the two 2-56 screws located at the top and bottom of the module (**Figure B**).
3. Insert the flat head screwdriver into the slot of the module and pry the end of the module using a twisting motion until visibly separated. Repeat on the opposite end of the module (**Figure B**).
4. Grasp the module halves and apply force in opposite directions, rocking the ends of the module while slightly pulling the top of the module away from the mating bottom section. Be sure to open both sides of the module simultaneously or contacts could be damaged.
5. Place the extraction tool (p/n 910110112) over the contact to be removed/replaced (**Figure C**). Use care to keep the tool perpendicular to the surface of the module, otherwise the tool or the contact could be bent.
6. Once the extraction tool is seated and the retaining tabs on the contact are compressed, depress the plunger. The contact will be pushed out of the rear of the module.
7. Replace the module top using both hands to push the separated halves together. Replace and tighten the module retaining screws to a maximum torque of 1.5 in-lbs [0.16 Nm].



DO NOT DEPRESS THE PLUNGER ON THE BACK OF THE EXTRACTION TOOL UNTIL THE TIP OF THE EXTRACTION TOOL HAS FULLY SEATED INTO THE MODULE AND COMPRESSED THE RETAINING TABS ON THE CONTACT.

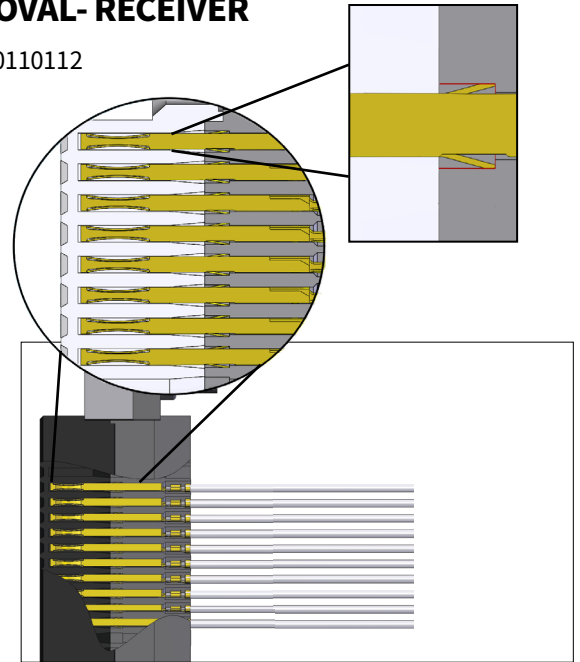

Figure A. Contacts installed in module.

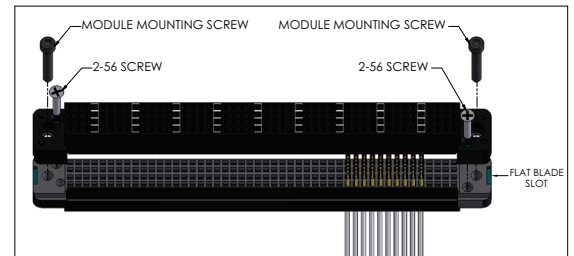

Figure B. Open both sides of the module simultaneously or pins could be damaged.

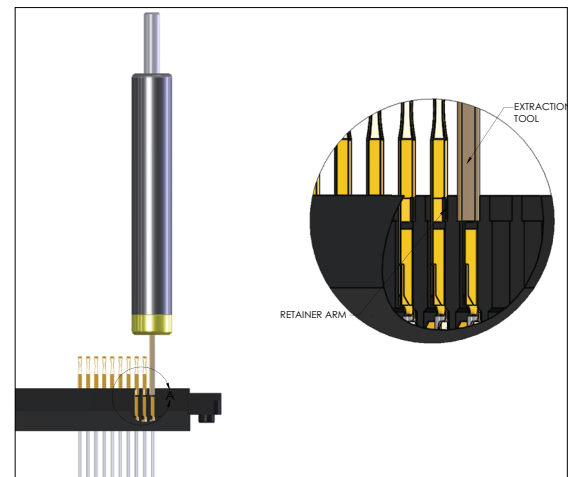

Figure C. Ensure that the tool is kept perpendicular to the module face to avoid damage to the contact and tool.

TWIN FEMALE CONTACT REPLACEMENT- RECEIVER

PART # 610138100, 610138117, 610138118, 610138200,
510150130, 510150131, 510150135, 510150136, 510150137, 510150147, 510160105

NOTE: These instructions specifically reference 90 Series modules, but also apply to iCon series modules.

TOOLS REQUIRED

Phillips Head Screwdriver
Flat Head Screwdriver
Needle Nose Pliers

REMOVAL

1. Remove the module from the receiver frame.
2. Use a Phillips head screwdriver to remove the two (2-56) screws located at the top and bottom of the module (**Figure A**).
3. Insert the flat blade screwdriver into the slot of the module and pry the end of the module using a twisting motion until visibly separated. Repeat on the opposite end of the module (**Figure A**).
4. Grasp the module halves and apply force in opposite directions, rocking the ends of the module while slightly pulling the top of the module away from the mating bottom section. Be sure to open both sides of the module simultaneously or contacts could be damaged.
5. Use a pair of tweezers or a small pair of needle nose pliers to grasp the contact. Pull the contact out of the module, taking care to avoid damaging surrounding contacts (**Figure B**).
6. If an adapter pin/ round post contact (p/n 610138117/118), needs to be removed, it can be taken out at this point by turning the module over, allowing it to fall out.

INSTALLATION

1. Remove the module from the receiver frame.
2. Use a Phillips head screwdriver to remove the two (2-56) screws located at the top and bottom of the module (**Figure A**).
3. Insert the flat blade screwdriver into the slot of the module and pry the end of the module using a twisting motion until visible separation is indicated. Repeat on the opposite end of the module (**Figure A**).
4. Grasp the module halves and apply force in opposite directions, rocking the ends of the module while slightly pulling the top of the module away from the mating bottom section. Be sure to open both sides of the module simultaneously or contacts could be damaged.
5. If an Adapter Pin/Round Post (Contact 610138117/118) needs to be installed, insert Adapter Pin/Round Post contact into the end of the 610138100 contact and then insert that end into the bottom half of the Receiver Module.
6. Align the square portion of the contact with the square opening in the module. Insert the contact into the bottom half of the module (**Figure C**).
7. Use your thumb or a flat, non-marring surface to press the end of the contact into the module.
8. Replace the module top using both hands to push the halves together. Replace and tighten the module retaining screws to a maximum torque of 1.5 in-lbs [0.16 Nm].

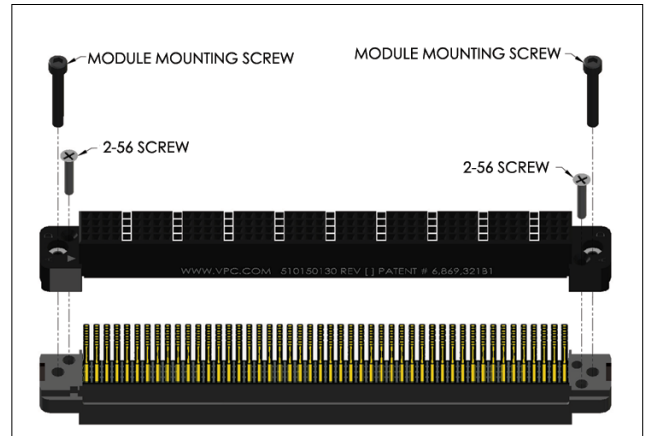

Figure A. The module is designed with a polarizing feature to make sure the cap is properly aligned.

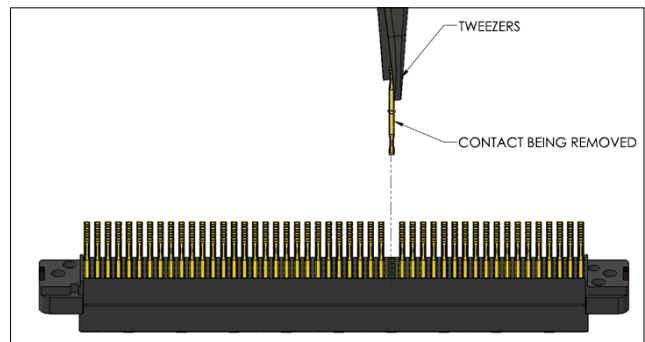

Figure B. Take care to avoid damaging contacts surrounding the one to be removed.

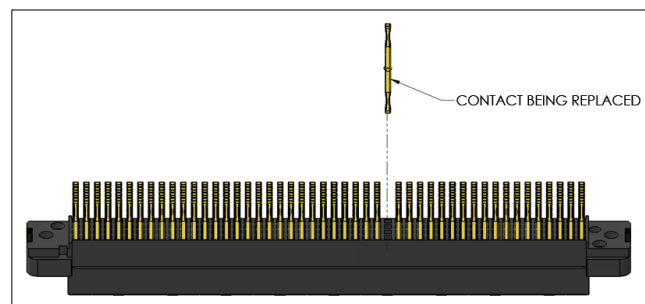

Figure C. Ensure the square portion of the contact is aligned with the square opening in the module.

PCB ADAPTER INSTALLATION AND REMOVAL- RECEIVER

PART # 510150125, 510150126, 510150127, 510150128,
510150141, 510150142, 510150148, 510150155

TOOLS REQUIRED

³/₃₂ Hex Wrench

INSTALLATION

- Using a ³/₃₂ hex wrench, install the receiver module into the receiver frame with the two provided 4-40 x 1¼” screws. The screws will extend approximately 0.75” to 1.0” [19-25 mm] beyond the rear of the receiver frame. Ensure that Position 1 is located at the top for systems in which the modules are oriented vertically or to the left for systems in which the modules are oriented horizontally (**Figure A**).
- Access the rear of the receiver frame and install the(4-40) stand-offs to the module's 4-40 X 1¼” retaining screws according to **Table 1 (Figure B)**.
- Align the PCB adapter's two threaded retaining sockets with the module 4-40 x 1¼” retaining screws with stand-offs installed (**Figure C**). Ensure that Pin Position 1 on the adapter corresponds with Pin Position 1 on the module.
- Using the ³/₃₂ hex wrench, carefully install the PCB adapter by tightening the retaining sockets, turning each no more than 1½ to 2 full turns before alternating to the other socket. Repeat this step until the PCB adapter is firmly engaged with the receiver module, taking care not to overtighten (max torque of 4 in-lbs [0.45 Nm]).

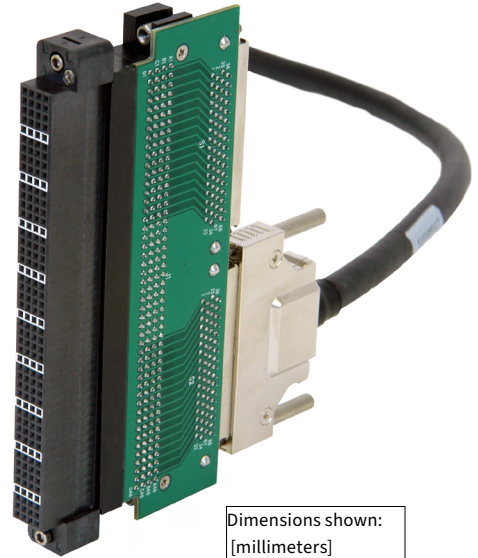

Dimensions shown:
[millimeters]
inches

RECEIVER FRAME MODEL	RECEIVER FRAME THICKNESS	STAND-OFF CONFIG (per mounting screw)
9025, 9025TR, 9050, 9075, S6, G12, and G12x	[13.84] 0.545	[3.18 mm] 1/8"
G2, G6, G10, and G18 (NON-PCB)	[9.27] 0.365	[7.94 mm] 5/16"
G10 (PCB) and G18 (PCB)	[6.35] 0.250	[3.18 mm] 1/8" and [7.94 mm] 5/16"

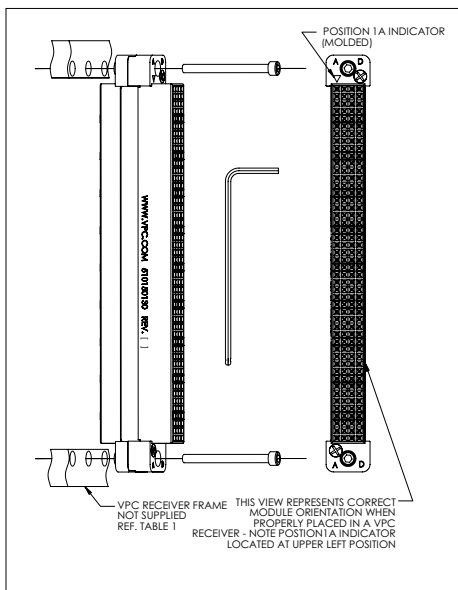

Figure A. Install receiver module onto receiver frame.

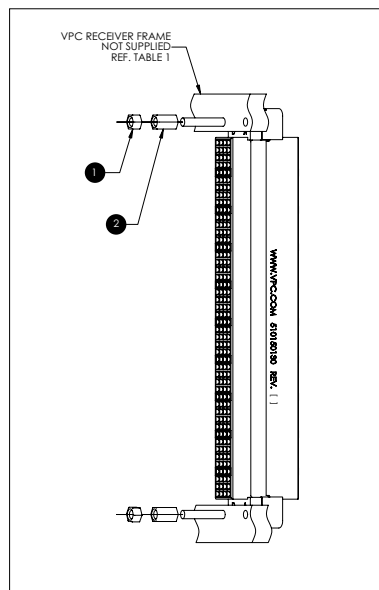

Figure B. Install proper stand-off.

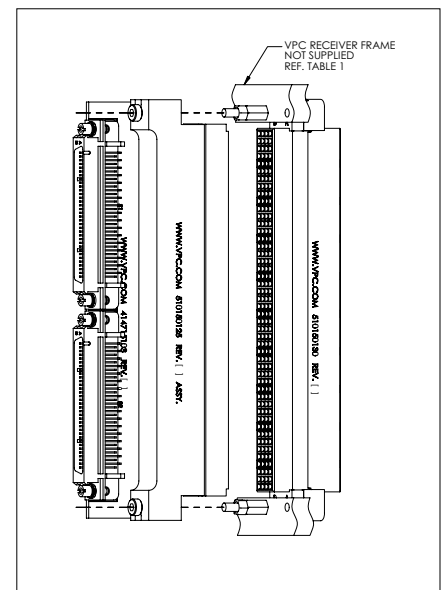

Figure C. Install PCB adapter.

[RETURN TO INDEX](#)

PCB ADAPTER INSTALLATION AND REMOVAL- RECEIVER (CONT'D)

PART # 510150125 , 510150126 , 510150127 , 510150128 ,
510150141 , 510150142 , 510150148 , 510150155

TOOLS REQUIRED

$\frac{3}{32}$ Hex Wrench

REMOVAL

- To remove the PCB adapter from the receiver frame and module, use the same alternating method of $1\frac{1}{2}$ to 2 turns until the PCB adapter is fully disengaged. Pull straight out to separate (**Figure D**), not at an angle (**Figure E**).

NOTE: Use caution when pulling apart the module from the PCB adapter, as damage to the upper/lower module frame can occur.

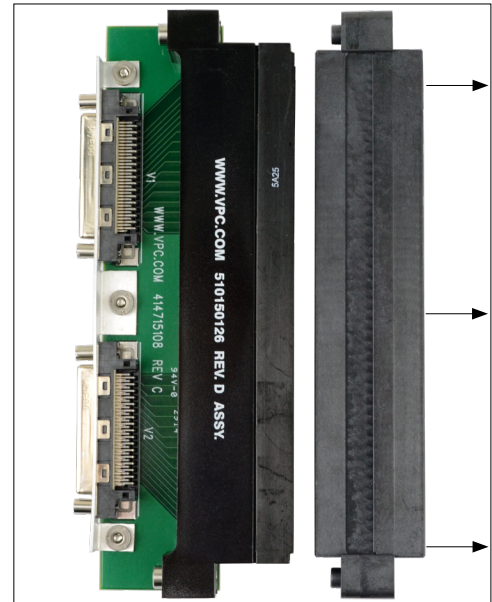

Figure D. Removal (Correct)



Figure E. Removal (Incorrect)

[RETURN TO INDEX](#)

CUSTOM PCB ASSEMBLY INSTALLATION AND REMOVAL- RECEIVER

PART # 510150152 , 510109315

TOOLS REQUIRED

- ³/₃₂ Hex Wrench
- Phillips Head Screwdriver

7	2	4-40 x .13 THREADED STAND OFF
6	2	4-40 x .31 THREADED STAND OFF
5	2	SCR FH PHL 2-56 x .31 SST
4	2	Scr Sh Cp 4-40 x 1.25 SST
3	1	192 PIN RT ANG ML HDR
2	2	SPCL SDR SCR SOCKET HEAD
1	1	SHRD FOR CSTMR SPLD PCB ASM KIT
ITEM NO.	QTY.	DESCRIPTION

INSTALLATION AND REMOVAL

- Solder the header to PCB (IPC-A-610 standard is recommended)(**Figure B**). The PCB must be manufactured with the header installation area complying with the recommended PCB layout (**Figure A**).
- Fasten the shroud assembly to the PCB using the two supplied 2-56 x .25 FH PHL screws (**Figure C**).
- Using a ³/₃₂" hex wrench, replace the two (4-40) receiver module mounting screws with the two supplied 4-40 x 1 ¼" screws (**Figure D**).
- Access the rear of the receiver frame and install all the provided (4-40) stand-offs according to (**Table 2**)(**Figure E**).

Table 1. Parts included with p/n 510109315. Key for figures B - F.

Dimensions shown:
[mm] inches

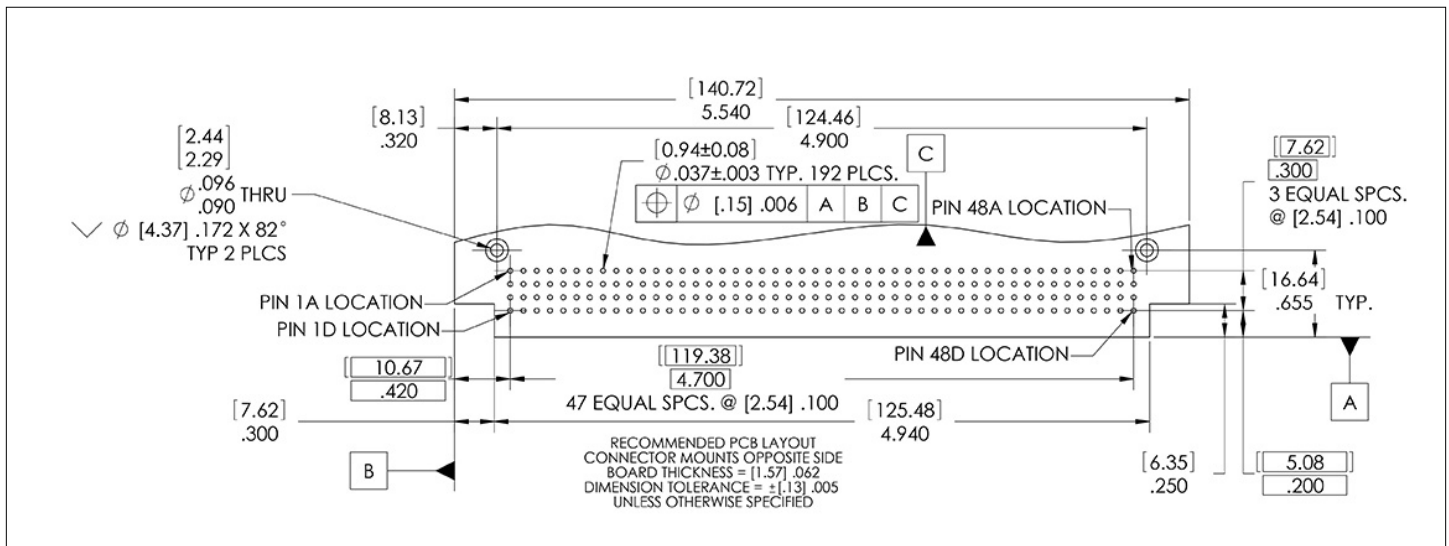

Figure A. Recommended PCB layout.

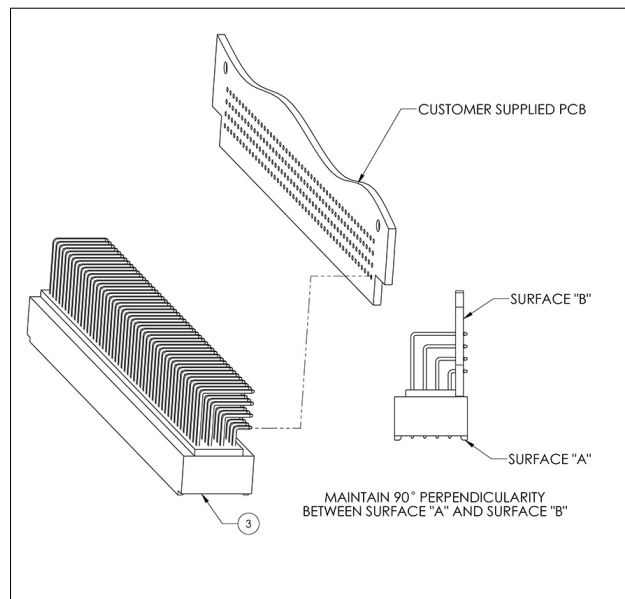

Figure B.

[RETURN TO INDEX](#)

CUSTOM PCB ASSEMBLY INSTALLATION AND REMOVAL- RECEIVER (CONT'D)

PART # 510109315, 510150130

5. Using a 3/32" hex wrench, carefully install the PCB assembly onto the rear of the receiver module ensuring that Pin Position 1A of the module and Pin Position 1A of the PCB Assembly match. For best results only rotate screws 1/2 to 2 turns alternately until assembly is complete. **DO NOT OVERTIGHTEN (Figure F).**
6. To remove the PCB assembly from the receiver frame and module, use the same alternating method of 1/2 to 2 turns until the PCB assembly is fully disengaged.

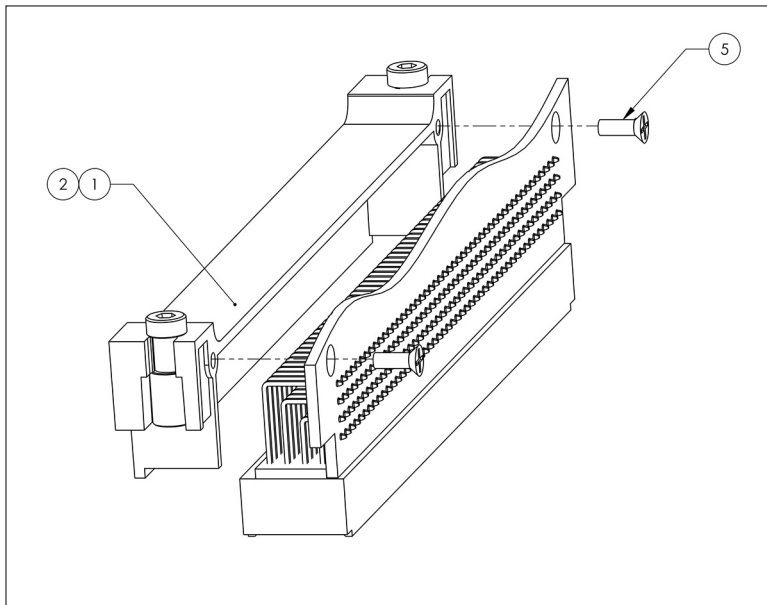

RECEIVER FRAME MODEL	RECEIVER FRAME THICKNESS	STAND-OFF CONFIG (per mounting screw)	PART TO BE USED (See Table 1)
9025, 9025TR, 9050, 9075, S6, G12, G12x	[13.84] .545	[3.18] .125	7
G2, G6, G10, G18 (non-PCB)	[9.27] .365	[7.94] .3125	8
G10 (PCB), G18 (PCB)	[6.35] .250	[3.18] .125 and [7.94] .3125	6,7

Table 2.

Dimensions shown:
[mm] inches

Figure C.

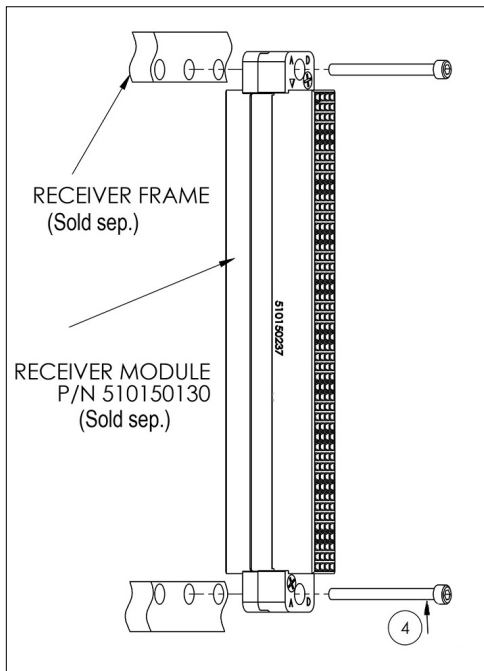

Figure D.

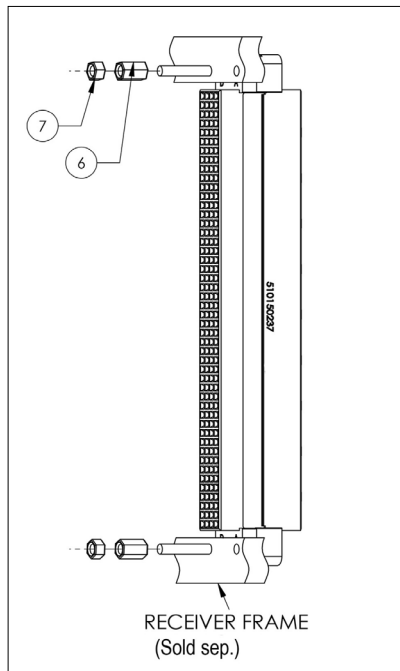

Figure E.

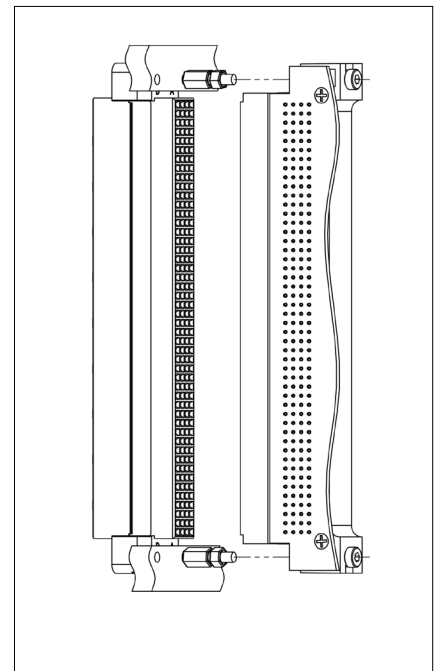

Figure F.

[RETURN TO INDEX](#)

CONTACT ASSEMBLY- ITA

PART # 610138109, 610138112, 910101103, 910104140



CRIMP TOOL SETUP

1. Set up the Crimp Tool (**Figure A**), by loosening the latch locking screw (counter-clockwise, until turning stops). Remove any previously used locator.
2. Insert the open end of the Locator (**Figure B**), into the crimp tool locator retainer. Slide the retaining latch toward the locator until the locator is securely locked into place. The locator may have to be twisted to allow the latch to retain it. Tighten the latch locking screw.

CRIMP TOOL ADJUSTMENT AND WIRE PREP

1. Adjust the crimp tool setting by pulling the microcrimp adjusting knob and turning it at the same time (clockwise increases, counter-clockwise decreases setting) until the desired setting is achieved on the microcrimp indicator (**Table 1**). Verify with gauge pin.
2. Determine the strip length according to wire gauge (**Table 1**). Strip wire.

CONTACT SETUP AND CRIMPING

1. Insert the contact into the crimp tool and squeeze the handle slightly to hold the contact in position for wire insertion.
2. Insert the stripped wire fully into the contact and squeeze the crimp tool handle until a positive stop is reached. The tool will release and return to a fully “open” position. Remove the crimped contact wire (**Figure C**).

NOTE: This contact can also be soldered.



PERFORM PRECISION RATCHET ACTION BY OPENING AND CLOSING TOOL FULLY SEVERAL TIMES. NOTE THAT THE TOOL CANNOT BE OPENED WITHOUT COMPLETING A CYCLE. NEVER ATTEMPT TO DISASSEMBLE TOOL. NEVER TIGHTEN OR LOOSEN STOP NUTS ON THE BACK OF THE TOOL.

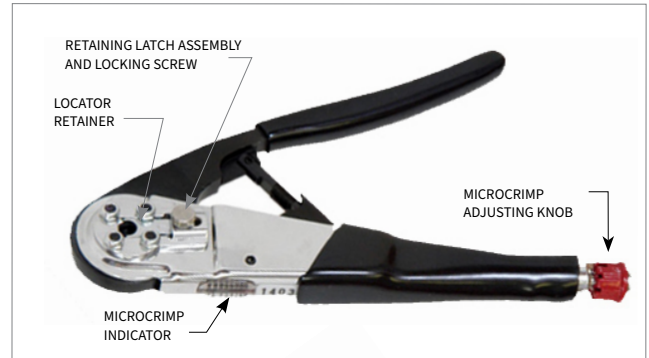

Figure A. Crimp Tool



Figure B. Locator

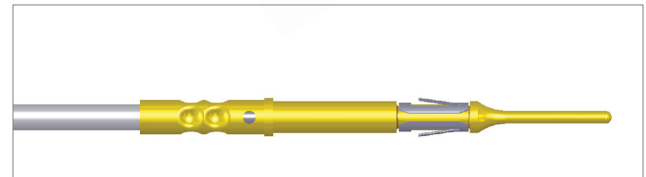

Figure C. Correctly crimped contact.

Table 1.

CONTACT	CRIMP TOOL	LOCATOR DIE	STRIP LENGTH (IN [MM])	INSULATION DIAMETER MAX (IN [MM])	WIRE GAUGE	CRIMP SETTING (IN [MM])		PULLOUT FORCE (LBS [N])	EXTRACTION TOOL
						MAX	MIN		
610138109	910101103	910104140	0.200 [5.08]	0.050 [1.27]	22	0.033 [0.83]	0.030 [0.76]	10 [44.5]	910110111
					24	0.028 [0.71]	0.026 [0.66]	8 [35.6]	
			2-24*		0.034 [0.86]	0.030 [0.83]	8 [35.6]		
			2-26*		0.029 [0.73]	0.027 [0.68]	4 [17.8]		
610138112	910101103	910104140	0.200 [5.08]	0.040 [1.02]	26	0.032 [0.81]	0.031 [0.79]	4 [17.8]	
					28	0.028 [0.71]	0.026 [0.66]	2 [8.9]	
					30**	0.028 [0.71]	0.026 [0.66]	1 [4.4]	

* Pullout force is for individual wires **Use 30 AWG filler wire for CMA build up refer to IPC-WHMA-A-620 section 5.3.5 for inspection criteria.

[RETURN TO INDEX](#)

CONTACT INSTALLATION AND REMOVAL- ITA

PART # 610138109, 610138112, 610138115, 910110111
510161101, 510151107, 510151108

NOTE: These instructions specifically refer to 90 Series modules, but also apply to iCon series modules.

INSTALLATION

1. Assemble the contact to the respective wire. *NOTE: For more information concerning the process of crimping the contact, see contact assembly instructions on page 8.*
2. Insert the assembled contact into the back (wiring side) of the assembled module (**Figure A**). The contact will only install into one side. Once in place, pull the wire slightly to ensure that the contact is fully seated.

REMOVAL

1. Remove the module from the ITA frame.
2. Place the extraction tool (**Figure B**), over the contact to be removed/replaced. Keep the tool perpendicular to the surface of the module to prevent bending or damage to the tool or contact. Rotate the tool slightly while pushing it into the counter bore on the mating side of the module. Do **NOT** push the plunger down until the extraction tool is fully inserted into the contact cavity.
3. Once the extraction tool is seated properly and the tabs on the retaining ring are compressed, push the plunger and the contact will be pushed out of the rear of the module.

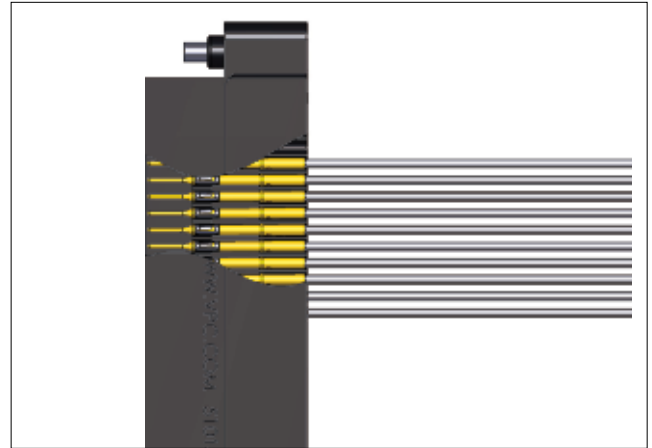

Figure A. Contacts fully installed in module.

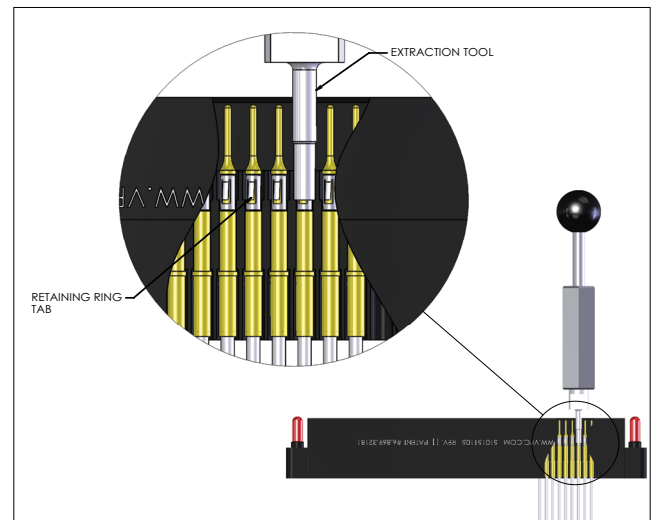

Figure B. Ensure extraction tool (p/n 910110111) is kept perpendicular to the module face to avoid damage to the contact or



DO NOT DEPRESS THE PLUNGER ON THE BACK OF THE EXTRACTION TOOL UNTIL THE TIP OF THE EXTRACTION TOOL HAS BEEN FULLY SEATED INTO THE MODULE AND FULLY COMPRESSED THE RETAINING RING TABS ON THE CONTACT.

IMPROPER EXTRACTION COULD DAMAGE THE CONTACT AND MODULE. THIS DAMAGE DONE CAN COMPROMISE THE SPACE BETWEEN CONTACTS, CREATING A CONDUCTIVE PATHWAY BETWEEN THE CONTACTS.

WIRE WRAP CONTACT INSTALLATION AND REMOVAL- ITA

PART # 610138122, 910113106, 910110111
510151124, 510151127

INSTALLATION

1. Insert the contact into the back (wiring side) of the module (**Figure A**). Make sure the contact is inserted as far as possible.
2. Place the QuadraPaddle Wire Wrap ITA Insertion Tool (p/n 910113106), onto the contact (**Figure B**).
3. Using the insertion tool, push the contact into the module until it is fully seated.
4. To ensure the contact is fully seated, pull on the square post lightly. If the contact is not seated, it will pull out of the module.

REMOVAL

1. Remove the module from the ITA frame.
2. Place the extraction tool over the mating end of the contact to be removed/ replaced. Keep the tool perpendicular to the surface of the module to prevent bending or damaging the tool or contact (**Figure C**). Rotate the tool slightly while pushing it into the counter bore on the mating side of the module.
3. Once the extraction tool is seated properly and the tabs on the retaining ring are compressed fully, push the plunger. The contact will be pushed out of the rear of the module.



DO NOT DEPRESS THE PLUNGER ON THE BACK OF THE EXTRACTION TOOL UNTIL THE TIP OF THE EXTRACTION TOOL HAS BEEN FULLY SEATED INTO THE MODULE AND COMPRESSED THE RETAINING RING TABS ON THE CONTACT.

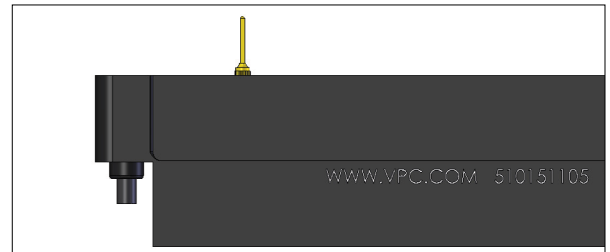

Figure A. Contact inserted into the back of the module.

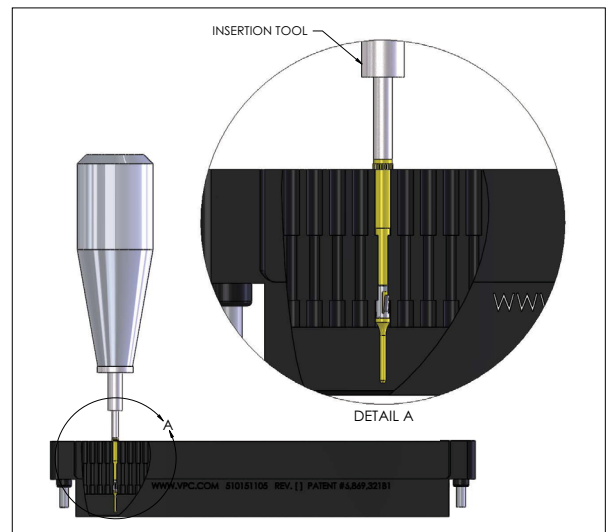

Figure B.

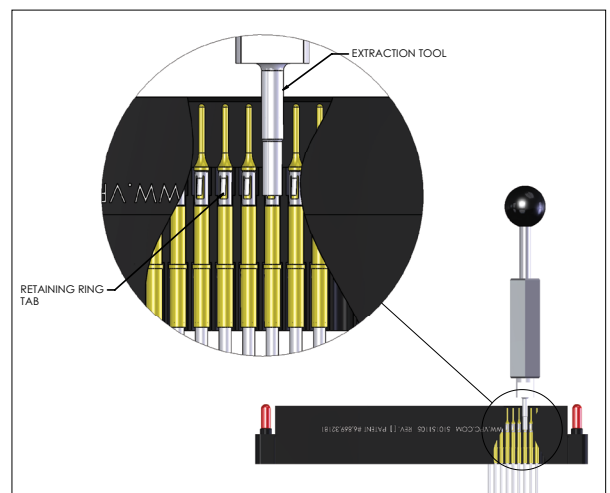

Figure C.

[RETURN TO INDEX](#)

PCB CONTACT INSTALLATION AND REMOVAL-ITA

PART # 610138123, 910113106

NOTE: These instructions specifically refer to 90 Series modules, but also apply to iCon series modules.

INSTALLATION

1. Insert the contact into the front (mating side) of the module (**Figure A**). Make sure to manually insert the contact as far as possible.
2. Place the tool onto the contact (**Figure B**).
3. Using the tool, push the contact into the module until it is fully seated.

REMOVAL

1. Remove the module from the ITA frame.
2. Place the tool over the non-mating end of the contact to be removed/replaced (**Figure C**). Use care to keep the tool perpendicular to the surface of the module to prevent bending and damaging the tool or contact.
3. Push the tool into the module until the contact is unseated. The contact will be pushed out the front of the module.



USE CAUTION TO ALWAYS KEEP THE TOOL PERPENDICULAR TO THE MODULE TO AVOID DAMAGE TO THE CONTACT OR TOOL.

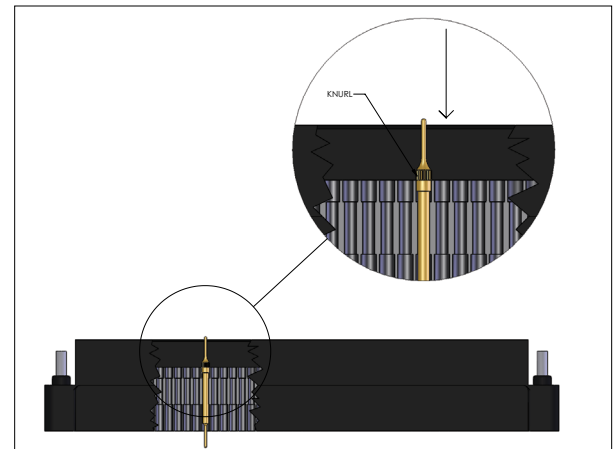

Figure A.

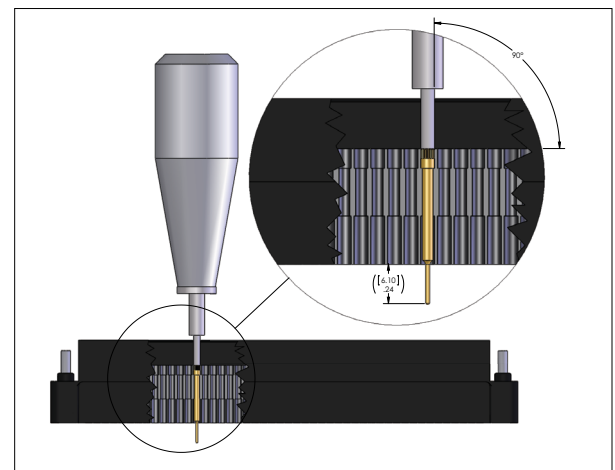

Figure B.

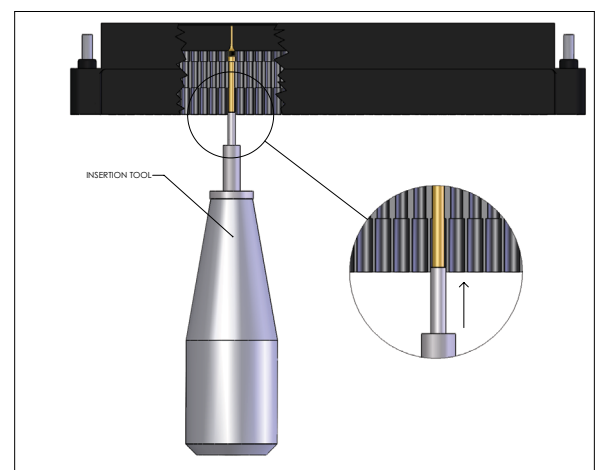

Figure C.

[RETURN TO INDEX](#)

PCB ADAPTER INSTALLATION AND REMOVAL-ITA

PART # 510109339, 510151123, 510151125

TOOLS REQUIRED

³/₃₂ Hex Wrench

INSTALLATION

1. Install the ITA module into the ITA frame using the two (4-40 double-ended) studs. The long end of the stud should pass through the ITA module (**Figure A**). Ensure that Position 1 is located at the top for systems in which the modules are oriented vertically or to the left for systems in which the modules are oriented horizontally.
2. Align the PCB adapter's two threaded retaining sockets with the (4-40 double-ended) studs (**Figure B**). Ensure that Position 1 on the adapter corresponds with Position 1 on the module.
3. Using the ³/₃₂ hex wrench, carefully tighten the retaining sockets, turning each no more than 1½ to 2 full revolutions before alternating to the other socket. Repeat this step until the PCB adapter is firmly engaged with the ITA module, taking care not to overtighten. Torque screws to 4 in-lbs [0.45 Nm].



REMOVAL

1. To remove the PCB adapter from the ITA frame and module, use the same alternating method of 1½ to 2 turns until the PCB assembly is fully disengaged.

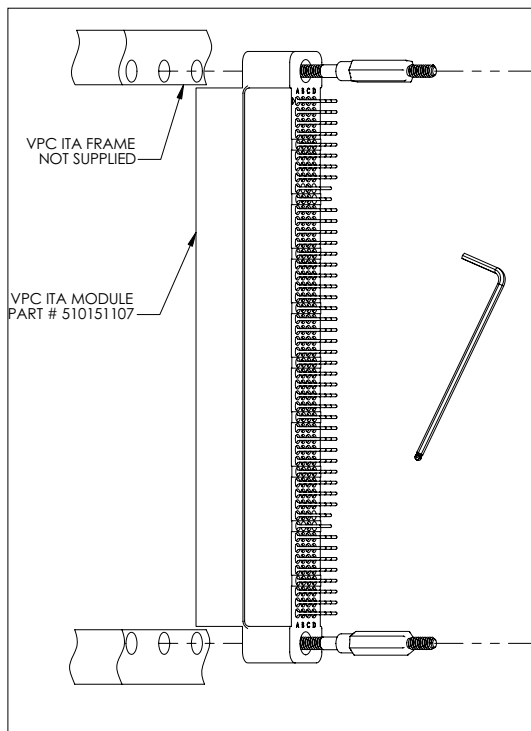

Figure A.

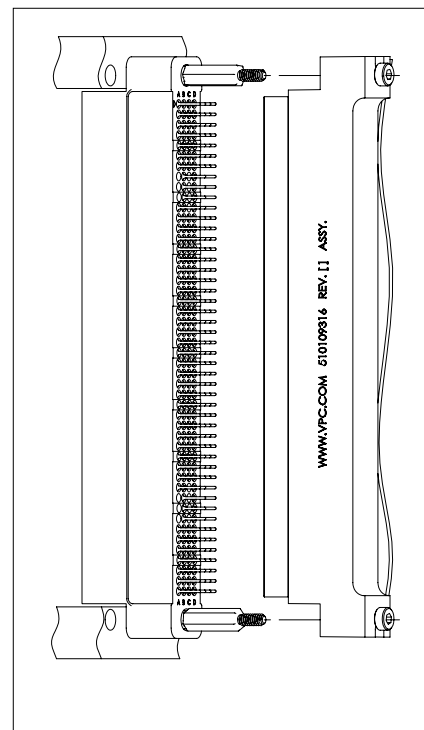

Figure B.

[RETURN TO INDEX](#)

CUSTOM PCB ASSEMBLY INSTALLATION AND REMOVAL- ITA

PART # 510109316, 510151107

TOOLS REQUIRED

- ³/₃₂ Hex Wrench
- Phillips Head Screwdriver

PCB ADAPTER INSTALLATION AND REMOVAL

- Solder header to the PCB (IPC-A-610 standard is recommended) (**Figure B**). The PCB must be manufactured with the header installation area complying with the recommended PCB layout (**Figure A**).
- A .020 perpendicular tolerance applies to a tolerance zone of [38.10] 1.50. Calculate tolerance accordingly for tolerance varying board heights (**Figure B**).
- If the application requires the use of multiple PCB adapters installed side-by-side in the ITA, a post-solder trimming operation is required to shorten the tails in order to eliminate interference between adjacent adapters or strain relief. Trim tails to length shown. The dimension represents maximum length after trimming (**Figure B**). Tails should be trimmed in accordance with IPC-A-610 standard section 6.5.1.

ITEM NO.	QTY.	DESCRIPTION
5	2	SCR FH PHL 2-56 x .25 LG. SST
4	2	DBL END STUD 4-40 w/ HEX BODY
3	1	192 PN RT ANG FML HEADER
2	2	SPCL SDR SCR SOCKET HEAD
1	1	192 PN HDR PCB SHROUD

Included with p/n 510109316. Key for figures B - E.

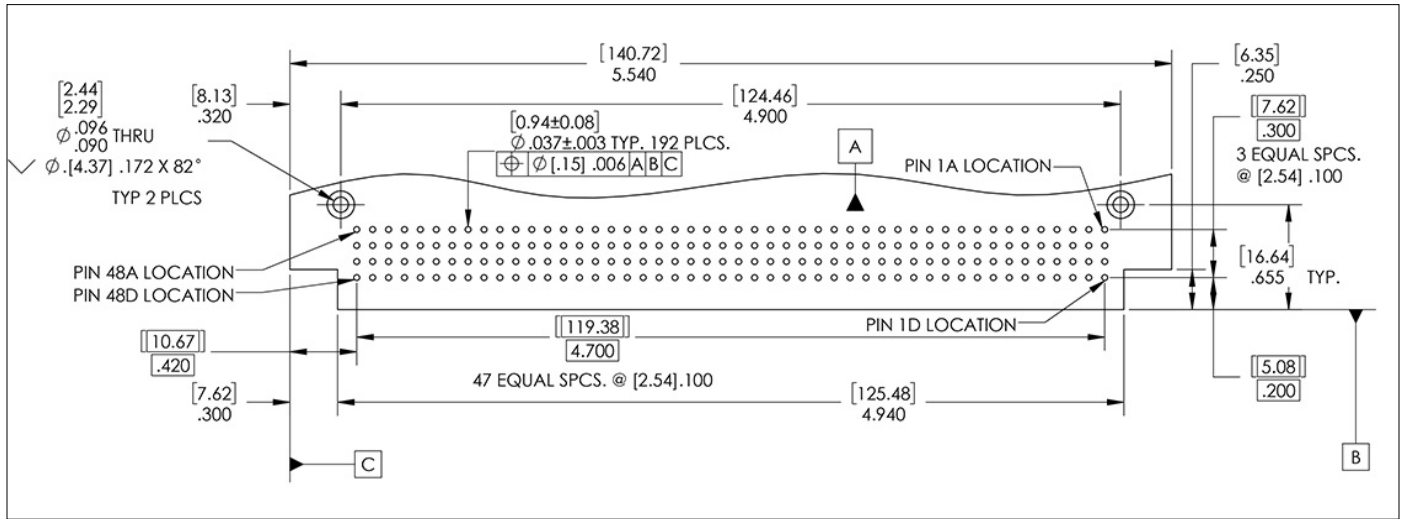
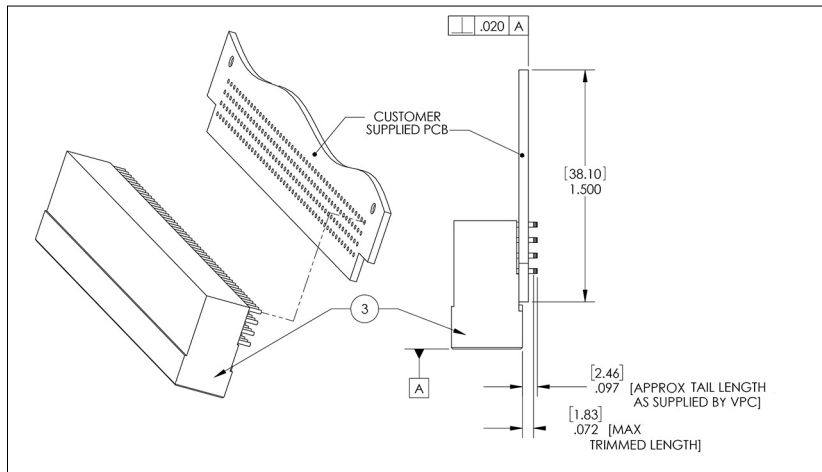

Figure A. Recommended PCB layout.



Dimensions shown:
[mm]
inches

Figure B.

[RETURN TO INDEX](#)

CUSTOM PCB ASSEMBLY INSTALLATION AND REMOVAL- ITA (CONT'D)

PART # 510109316, 510151107

NOTE: The header must be soldered to the PCB before completing the following steps!

4. Fasten the shroud assembly to the PCB using the two provided 2-56 x .25 FH PHL screws (**Figure C**).
5. Using a 3/32" hex wrench remove the two (4-40) screws used for ITA module mounting and replace them with the two (4-40) DBL END STUDS). The long end of the stud should pass through the ITA module (**Figure D**).
6. Using a 3/32" hex wrench, carefully install the PCB assembly onto the backside of the ITA module ensuring module Pin Position 1 and Pin Position 1 of the PCB assembly match.
7. For best results only turn screws 1 1/2 - 2 turns each, alternating until assembly is completed (**Figure E**). DO NOT OVERTIGHTEN.
8. To remove the PCB assembly from the ITA module, use the same alternating pattern of 1 1/2 to 2 turns until the PCB assembly is fully disengaged.

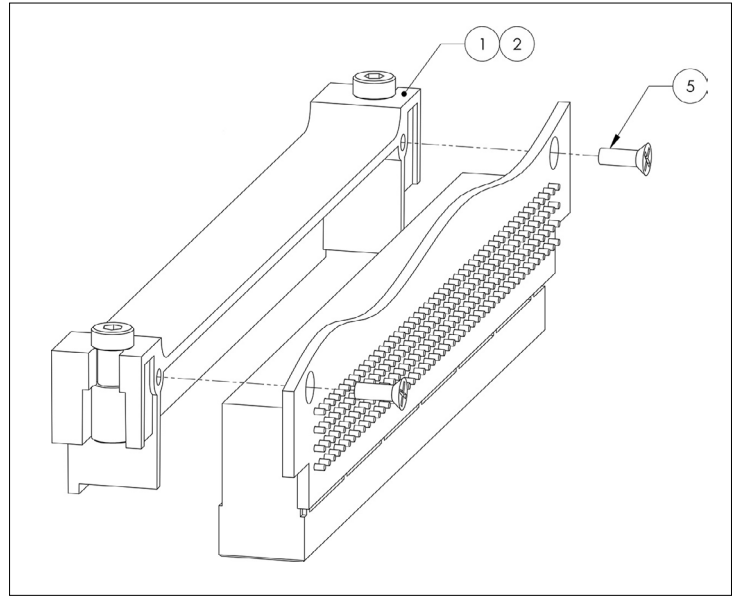

Figure C.

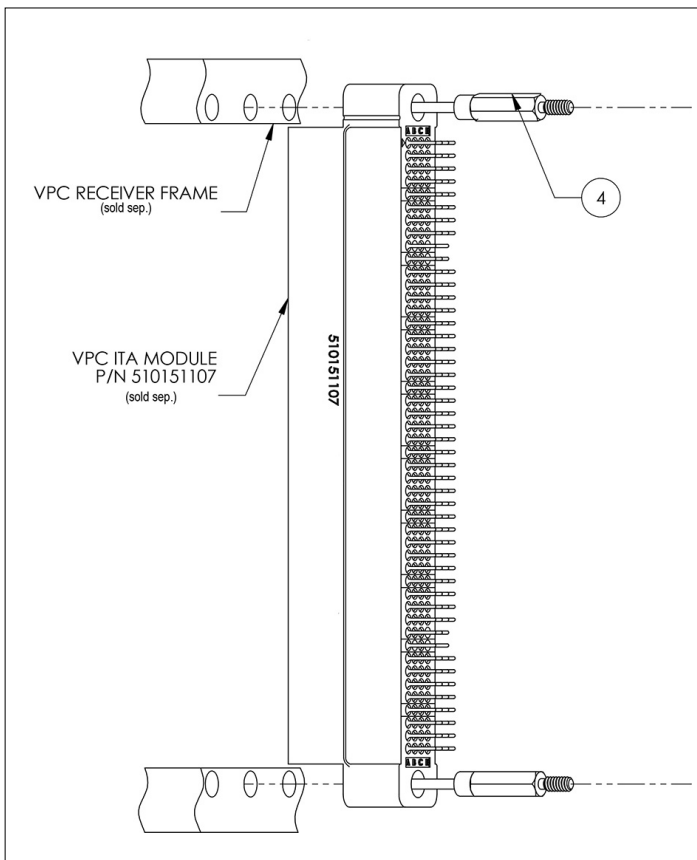

Figure D.

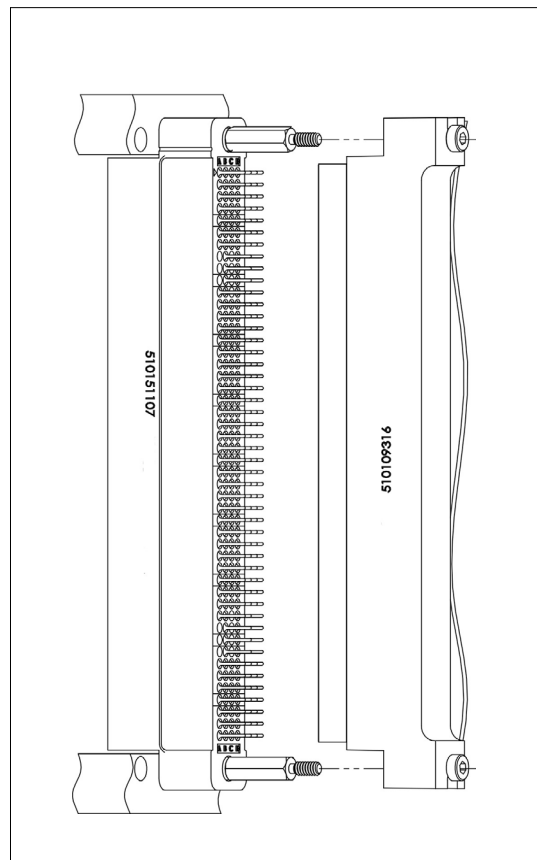

Figure E.

[RETURN TO INDEX](#)

WIRE WRAP CONTACT TERMINATION

PART # 610138122, 610138118

TOOLS REQUIRED

Wire Stripping Tool
Wire-wrap gun
Wire-wrap bit

ASSEMBLY INSTRUCTIONS

NOTE: VPC performs wire-wrap terminations in accordance with IPC-A-620 standards.

NOTE: Wire-wraps must be performed with solid wire. Stranded wire will not work for wire wrapping. VPC recommends 26 to 30 AWG wire.

1. Cut and strip the wire. Depending on the style of wire-wrap gun and bit used, the wire is either stripped during the wrapping process or needs to be stripped before the wrapping process.

NOTE: Refer to the user manual for your wire-wrap gun to determine how your specific tool operates.

2. Insert the wire into the wire slot of the wire-wrap gun. With modified and standard bits insert the wire in the wire slot as deeply as possible. With C.S.W. bits the wire has to be inserted all the way through the wire slot until it goes out of the cutting window. The simplified sleeve of the manual tool has no notch.
3. Hold the wire in place by hand (**Figure A**).
4. Position the terminal hole of the wire-wrap gun on the post to be wrapped. The wire-wrap gun should be parallel with the contact. The wire must continue to be held in place by hand.
5. Engage the wire-wrap gun to wrap the wire. During the wrapping operation, gently press the tool forward onto the wire-wrap post. The turns of the connection have to be nicely wrapped against the other. Do not push too hard. Do not pull backwards. See (**Figure B**) for an example of a terminated contact in a module.

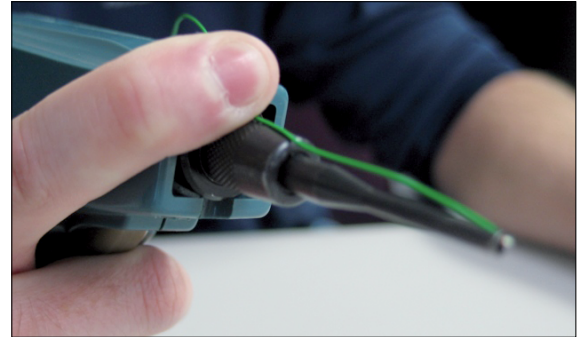

Figure A. Hold the wire in place by hand.

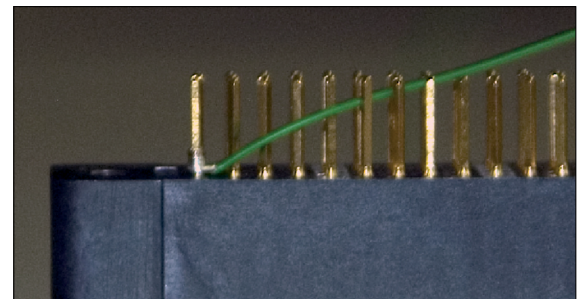

Figure B. Completed wrapped wire.

MODULE INSTALLATION AND REMOVAL- 90 SERIES

PART# 510150115, 510150116, 510150130, 510150131, 510150135, 510150136, 510150137, 510150147, 510150152
510109316, 510151105, 510151106, 510151107, 510151108, 510151121, 510151124, 510151127

TOOLS REQUIRED

$\frac{3}{32}$ Hex Wrench

INSTALLATION

1. Place the module in the receiver or ITA until the upper and lower module screws touch the mating holes in the inner frame. Ensure that Pin Position 1 is located at the top for systems in which the modules are oriented vertically, or to the left for systems in which the modules are oriented horizontally.
2. Using a $\frac{3}{32}$ hex wrench, tighten the top screw 1 to 2 full turns, while pushing lightly against the face of the module.
3. Maintain this pressure while tightening the bottom screw 1 to 2 full turns.
4. Repeat this sequence until the module is seated. Torque the screw to 4 in-lbs [0.45 Nm].

REMOVAL

1. To remove, loosen the top screw 1 to 2 full turns and then the bottom screw 1 to 2 full turns.
2. Repeat this sequence until the module is separated from the receiver or ITA.

NOTE: For optimum performance and system longevity, distribute the contact load evenly throughout the module.

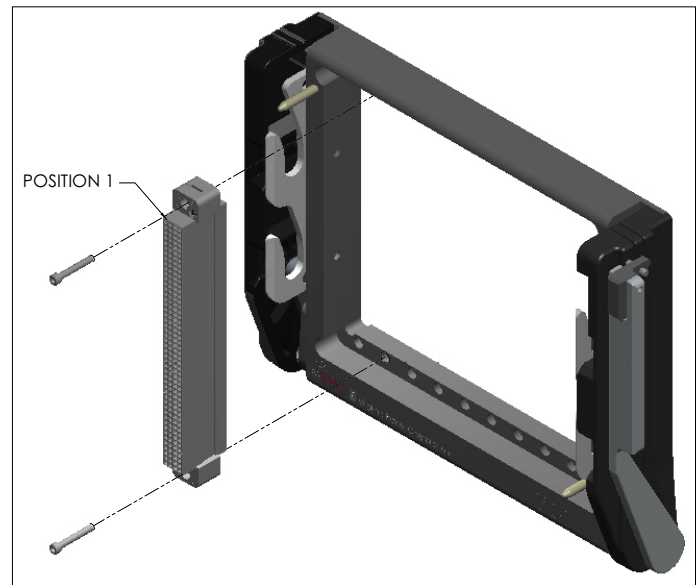

Figure A. Receiver Module.

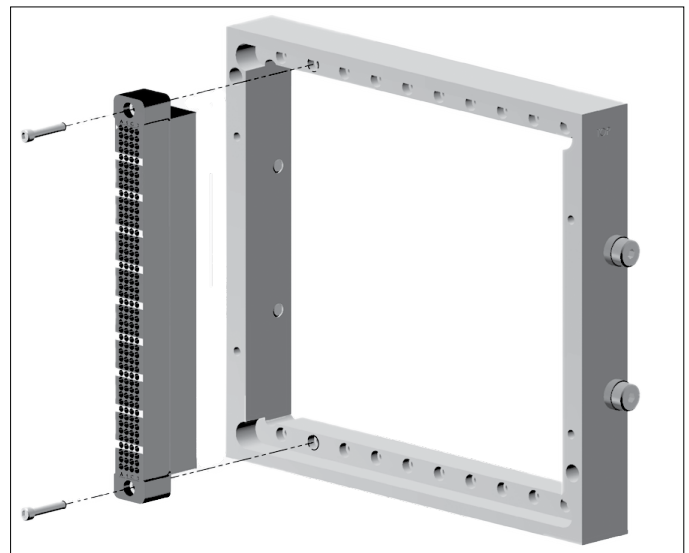

Figure B. ITA Module.

MODULE INSTALLATION AND REMOVAL- ICON SERIES

PART # 510160101, 510160102, 510160105, 510160107, 510160112, 510160113, 510160122,
510161101, 510161102, 510161107

TOOLS REQUIRED

Phillips Head Screwdriver

INSTALLATION

NOTE: The receiver strain relief plate or the ITA cover may need to be removed prior to installing or removing an iCon module. Please refer to the appropriate User Manual for appropriate instructions.

NOTE: For optimum performance and system longevity, distribute the contact load evenly throughout the module.

1. Place the module in the receiver or ITA until the upper and lower module screws touch the mating holes in the frame. Install modules such that Position 1 is located at the top of the ITA/receiver frame.
2. Using a Phillips head screwdriver, tighten the top screw 1 to 2 full revolutions, while pushing lightly against the face of the module.
3. Maintain this pressure while tightening the bottom screw 1 to 2 full revolutions.
4. Repeat this sequence until the module is seated. Torque the screw to 1.5 in-lbs [0.16 Nm].

REMOVAL

1. To remove, loosen the top screw 1 to 2 full revolutions. Loosen bottom screw 1 to 2 full revolutions.
2. Repeat this sequence until the module is separated from the receiver or ITA.

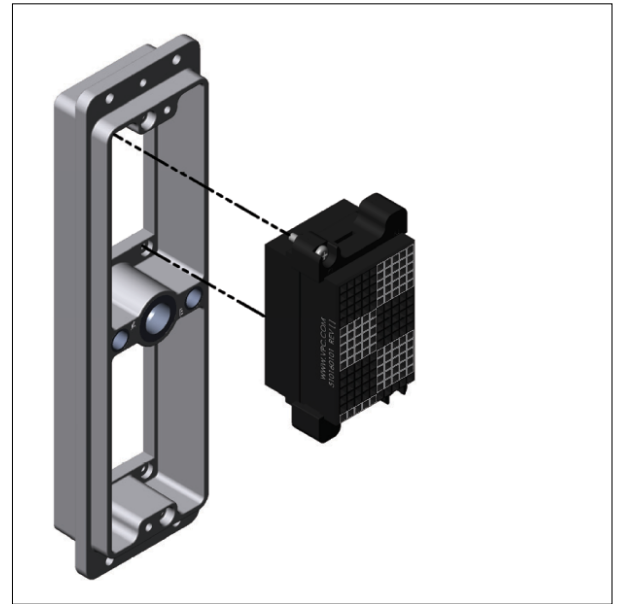

Figure A. Receiver Module.

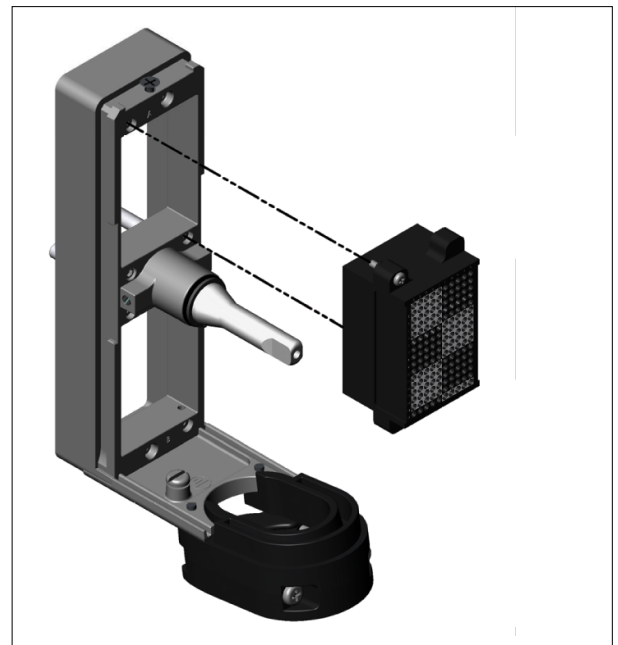

Figure B. ITA Module.

TWIN FEMALE/TWIN MALE MODULE TO PCB LAYOUT AND MOUNTING

PART # 510150130 , 510150137 , 510151107 , 510150131 , 510150135 , 510151108

1. Modules with twin female contacts can be used to connect directly to a PCB mounted male header (**Figure A**).
2. Modules with twin male posts can be soldered directly to a PCB or attached to a female header soldered directly to the PCB (**Figure B**).

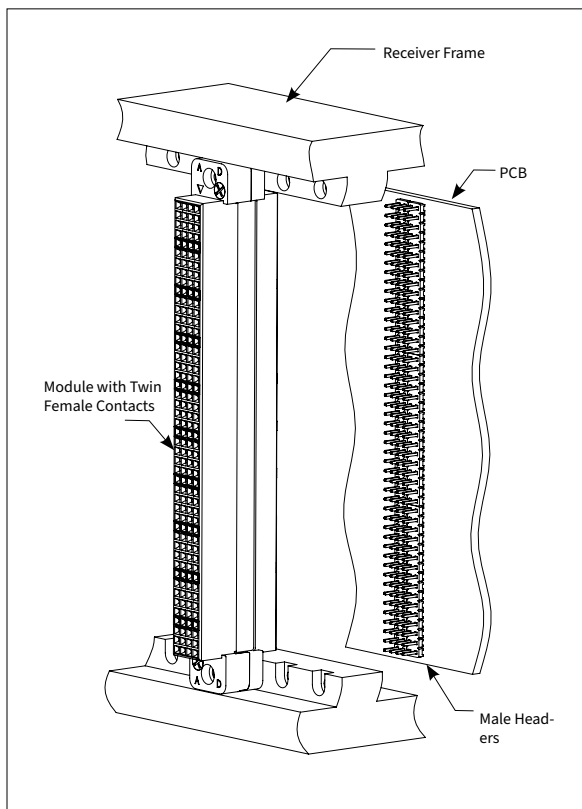

Figure A. Module with twin female contacts.

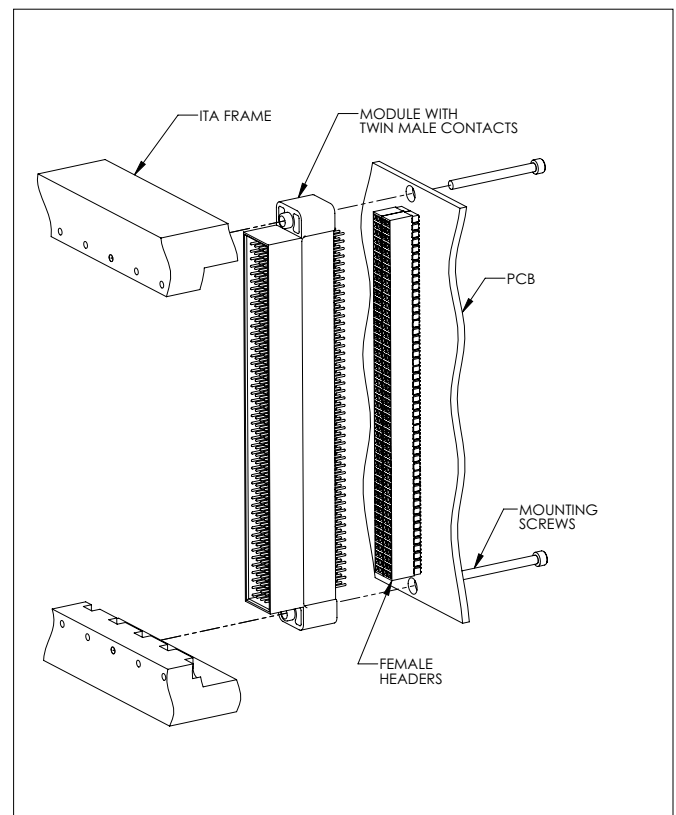

Figure B. Module with twin male contacts.

CROSS REFERENCE TABLES

RECEIVER CONTACTS	STANDARD/ 90 SERIES RECEIVER MODULES								CASS/ 80 SERIES RECEIVER MODULE	ICON RECEIVER MODULES					CRIMP TOOL	EXTRACTION
	510150115	510150116	510150130	510150131	510150135	510150136	510150137	510150147	510114131	510160101	510160102	510160105	510160107	510160112	910101125	910 10112
610138100			X	X	X	X	X	X				X		X		
610138116	X	X							X	X	X		X		X	X
610138117*			X	X	X		X					X		X		
610138118*			X	X		X		X				X		X		
610138216	X	X								X	X		X		X	X

*May be used with Part # 610138100

ITA CONTACTS	STANDARD/ 90 SERIES ITA MODULES						CASS/ 80 SERIES ITA MODULE	ICON ITA MODULES			CRIMP TOOL	LOCATOR	EXTRACTION	INSERTION
	510151105	510151106	510151107	510151108	510151124	510151127	510114131	510161101	510161102	510161107	910101103	910104140	910110111	910113106
610138109	X	X					X	X	X	X	X	X	X	
610138112	X	X					X	X	X	X	X	X	X	
610138115	X	X	X	X				X	X	X			X	
610138122	X	X			X	X		X	X	X			X	X