



ASSEMBLY, INSTALLATION, AND REMOVAL OF CONTACTS AND MODULES

FOR THERMOCOUPLE CONTACTS AND MODULES

INDEX (CLICK TO NAVIGATE TO PAGE)

PAGE

RECEIVERS

1 [RECEIVER CONTACT ASSEMBLY](#)

2 [RECEIVER CONTACT INSTALLATION & REMOVAL](#)

ITAS

3 [ITA CONTACT ASSEMBLY](#)

4 [ITA CONTACT INSTALLATION & REMOVAL](#)

MODULES & SPECIFICATIONS

5 [90 SERIES MODULE INSTALLATION & REMOVAL](#)

6 [ICON MODULE INSTALLATION & REMOVAL](#)

7 [PERFORMANCE SPECIFICATIONS](#)

8 [CROSS REFERENCE TABLES](#)

*Please note that any printed or downloaded User Manuals may not reflect the most current revisions.
The information contained in these materials is subject to change.
For the most current information available, visit vpc.com.*

RECEIVER CONTACT ASSEMBLY

PART # 610113131 / 610113132 / 610113148 / 610113168 / 910101102 / 910104134



NOTE: Thermocouple contacts should be used in pairs with K Type Thermocouple wire. 610113131 is Chromel and should be used with the yellow or positive wire and 610113132 is Almel and should be used with the red or negative wire.

CRIMP TOOL SETUP

1. Set up the Crimp Tool, Part # 910101102 (**Figure A**), by loosening the latch locking screw. Turn counter-clockwise to loosen. Remove any previously used locator.
2. Insert the open end of the Locator, Part # 910104134 (**Figure B**), into the locator retainer.
3. Slide the retaining latch toward the locator until the locator is securely locked into place. Tighten the latch locking screw.

CRIMP TOOL ADJUSTMENT AND WIRE PREPARATION

1. Adjust the crimp tool setting by pulling the microcrimp adjusting knob and turning it at the same time (clockwise increases, counter-clockwise decreases setting) until the desired setting is achieved on the microcrimp indicator (**Table 1**). Verify with pin gauge.
2. Strip wire to the appropriate length (**Table 1**).

CONTACT SETUP AND CRIMPING

1. Insert the contact into the crimp tool and squeeze the handle slightly to hold the contact in position for wire insertion.
2. Insert stripped wire fully into the contact and squeeze the crimp tool handle until a positive stop is reached. The tool will release and return into a fully “open” position. Remove crimped contact and wire.

OBSERVE PRECISION RATCHET ACTION BY OPENING AND CLOSING CRIMP TOOL FULLY SEVERAL TIMES. NOTE THAT TOOL CANNOT BE OPENED WITHOUT COMPLETING A CYCLE. NEVER ATTEMPT TO DISASSEMBLE TOOL. NEVER TIGHTEN OR LOOSEN STOP NUTS ON BACK OF TOOL.



Table 1. Crimp Settings.

CONTACT	CRIMP TOOL	LOCATOR DIE	STRIP LENGTH (IN [MM])	WIRE GAUGE	CRIMP SETTING (IN [MM])		PULLOUT FORCE (LBS [N])	EXTRACTION TOOL
					MAX	MIN		
610113131 610113132 610113148 610113168	910101102	910104134	0.250 [6.35]	20	0.047 [1.19]	0.046 [1.17]	10 [44.5]	910110102
24				0.033 [0.84]	0.029 [0.74]			

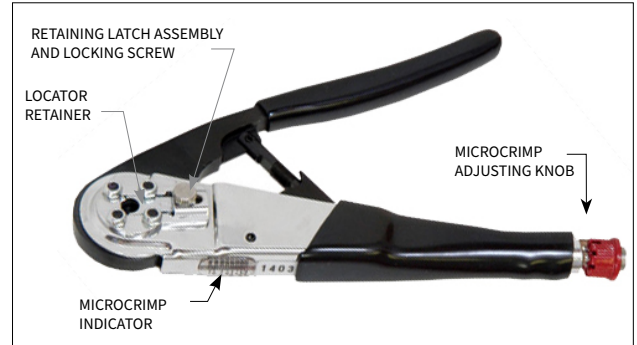

Figure A. Crimp Tool, Part # 910101102.

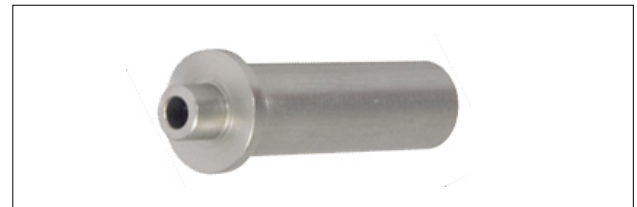

Figure B. Locator, Part # 910104134.

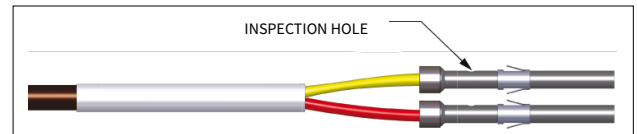

Figure C. Final assembled contact.

RECEIVER CONTACT INSTALLATION AND REMOVAL

PART # 610113131 / 610113132 / 610113148 / 610113168 / 910110102

TOOLS REQUIRED

$\frac{5}{64}$ Allen Wrench

Phillips Head Screwdriver (for iCon Modules)

CONTACT INSTALLATION INSTRUCTIONS

- Assemble the contact to the respective wire.
NOTE: For more information concerning the process of crimping the contact please see contact assembly instructions in this User Manual.
- Insert the assembled contact into the back (wiring side) of the assembled module (**Figure A**). The contact can only go into one side. Push the contact forward. Once in place, pull the wire slightly to ensure that the contact is seated.

CONTACT REMOVAL INSTRUCTIONS

- Remove the module from the receiver frame.
NOTE: For more information concerning the process of removing the module from the receiver frame, see module installation and removal instructions in this User Manual.
- Use a $\frac{5}{64}$ Allen wrench or Phillips head screwdriver to remove the two 2-56 screws located at the top and bottom of the module (**Figure B**).
- Grasp the module halves and apply force in opposite directions, rocking the ends of the module while slightly pulling the top of the module away from the mating bottom section. Be sure to open both sides of the module simultaneously or contacts could be damaged.
- Place the Thermocouple Receiver/ITA Extraction Tool, Part # 910110102, over the contact to be removed/replaced (**Figure C**). Use care to keep the tool perpendicular to the surface of the module, otherwise the tool or the contact could be bent.
- Once the extraction tool is seated and the retaining ring tabs on the contact are compressed, push the tool into the module. The contact will be pushed out of the rear of the module.

DO NOT DEPRESS THE PLUNGER ON THE BACK OF THE EXTRACTION TOOL UNTIL THE TIP OF THE EXTRACTION TOOL HAS FULLY SEATED INTO THE MODULE AND COMPRESSED THE RETAINING RING TABS ON THE CONTACT.



- On the opposite side of the module from the extraction tool, grasp the contact and hold it while removing the extraction tool. This will prevent the contact from being pulled back into the module while the tool is being removed.

- Replace the module cap using both hands to push the separated halves together. Replace and tighten the module retaining screws to a maximum torque of 2 in-lbs [0.23 Nm].

NOTE: The process shown here uses standard/90 Series modules. The same process is used for modules from other series.

NOTE: If you are using a hybrid module, you may need to reference the User Manual for the other contact type for extraction instructions.

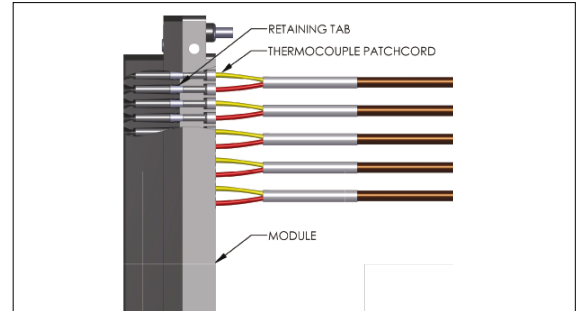

Figure A. Contacts inserted into the module.

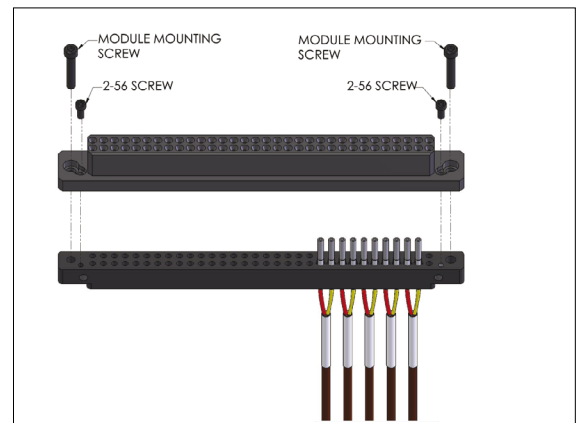

Figure B. Open both sides of the module simultaneously or pins could be damaged.

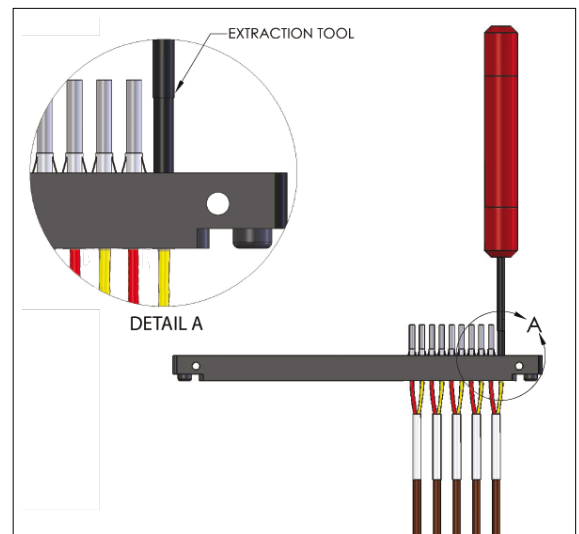
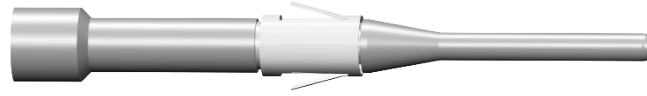

Figure C. Ensure that the tool is kept perpendicular to the module face to avoid damage to the contact or tool.

[RETURN TO INDEX](#)

ITA CONTACT ASSEMBLY

PART # 610113133 / 610113134 / 610113149 / 610113169 / 910101102 / 910104135



NOTE: Thermocouple contacts should be used in pairs with K Type thermocouple wire. 610113133 is Chromel and should be used with the yellow or positive wire and 610113134 is Alumel and should be used with the red or negative wire.

CRIMP TOOL SETUP

1. Set up the Crimp Tool, Part # 910101102 (**Figure A**), by loosening the latch locking screw. Turn counter-clockwise to loosen. Remove any previously used locator.
2. Insert the open end of the Locator, Part # 910104135 (**Figure B**), into the locator retainer.
3. Slide the retaining latch toward the locator until the locator is securely locked into place. Tighten the latch locking screw.

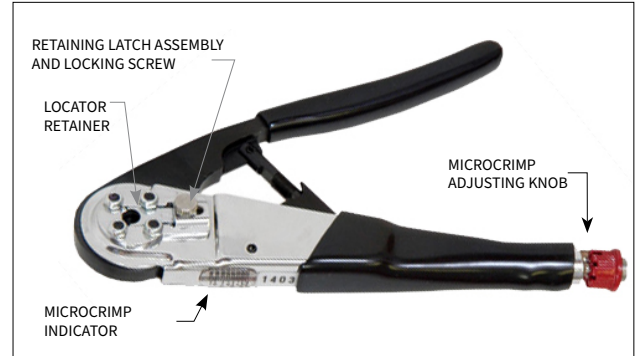

Figure A. Crimp Tool, Part # 910101102.

CRIMP TOOL ADJUSTMENT AND WIRE PREPARATION

1. Adjust the crimp tool setting by pulling the microcrimp adjusting knob and turning it at the same time (clockwise increases, counter-clockwise decreases setting) until the desired setting is achieved on the microcrimp indicator (**Table 1**). Verify with pin gauge.
2. Strip wire to the appropriate length (**Table 1**).

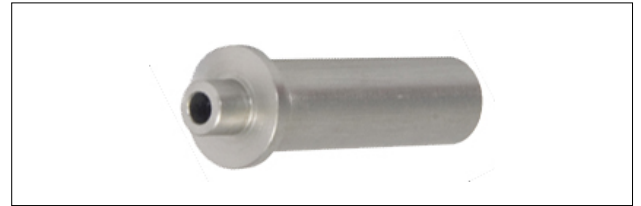

Figure B. Locator, Part # 910104135.

CONTACT SETUP AND CRIMPING

1. Insert the contact into the crimp tool and squeeze the handle slightly to hold the contact in position for wire insertion.
2. Insert stripped wire fully into the contact and squeeze the crimp tool handle until a positive stop is reached. The tool will release and return into a fully “open” position. Remove crimped contact and wire.

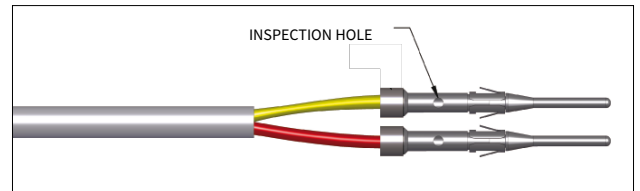

Figure C. Final assembled contact.

OBSERVE PRECISION RATCHET ACTION BY OPENING AND CLOSING CRIMP TOOL FULLY SEVERAL TIMES. NOTE THAT TOOL CANNOT BE OPENED WITHOUT COMPLETING A CYCLE. NEVER ATTEMPT TO DISASSEMBLE TOOL. NEVER TIGHTEN OR LOOSEN STOP NUTS ON BACK OF TOOL.



Table 1. Crimp Settings.

CONTACT	CRIMP TOOL	LOCATOR DIE	STRIP LENGTH (IN [MM])	WIRE GAUGE	CRIMP SETTING (IN [MM])		PULLOUT FORCE (LBS [N])	EXTRACTION TOOL
					MAX	MIN		
610113133 610113134 610113149 610113169	910101102	910104135	0.250 [6.35]	20	0.047 [1.19]	0.046 [1.17]	10 [44.5]	910101102
				24	0.033 [0.84]	0.029 [0.74]		

ITA CONTACT INSTALLATION AND REMOVAL

PART # 610113133 / 610113134 / 610113149 / 610113169 / 910110102

TOOLS REQUIRED

Thermocouple Receiver/ITA Extraction Tool, Part # 910110102

CONTACT INSTALLATION INSTRUCTIONS

1. Assemble the contact to the respective wire.
NOTE: For more information concerning the process of crimping the contact please see contact assembly instructions in this User Manual.
2. Insert the assembled contact into the back (wiring side) of the assembled module (**Figure A**). Push the contact forward. Once in place, pull the wire slightly to ensure that the contact is seated.

CONTACT REMOVAL INSTRUCTIONS

1. Remove the module from the ITA frame.

NOTE: For more information concerning the process of removing the module from the ITA frame, see module installation and removal instructions in this User Manual.

2. Place the Thermocouple Receiver/ITA Extraction Tool, Part # 910110102, over the contact to be removed/replaced (**Figure B**). Use care to keep the tool perpendicular to the surface of the module as not to bend the tool or the contact to be removed. Rotate the tool slightly while pushing it into the counter bore on the mating side of the module.
3. Once the extraction tool is seated properly and the retaining ring tabs on the contact are compressed, push the tool into the module. The contact will be pushed out of the rear of the module.



DO NOT DEPRESS THE PLUNGER ON THE BACK OF THE EXTRACTION TOOL UNTIL THE TIP OF THE EXTRACTION TOOL HAS FULLY SEATED INTO THE MODULE AND COMPRESSED THE RETAINING RING TABS ON THE CONTACT.

4. On the opposite side of the module from the extraction tool, grasp the contact and hold it while removing the extraction tool. This will prevent the contact from being pulled back into the module while the tool is being removed.

NOTE: The process shown here uses standard/90 Series modules. The same process is used for modules from other series.

NOTE: If you are using a hybrid module, you may need to reference the User Manual for the other contact type for extraction instructions.

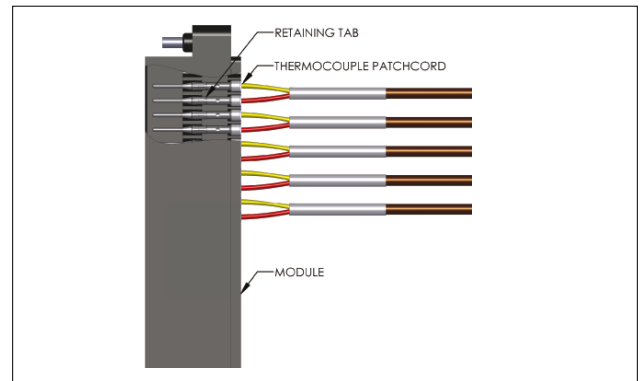

Figure A. Contacts inserted into the module.

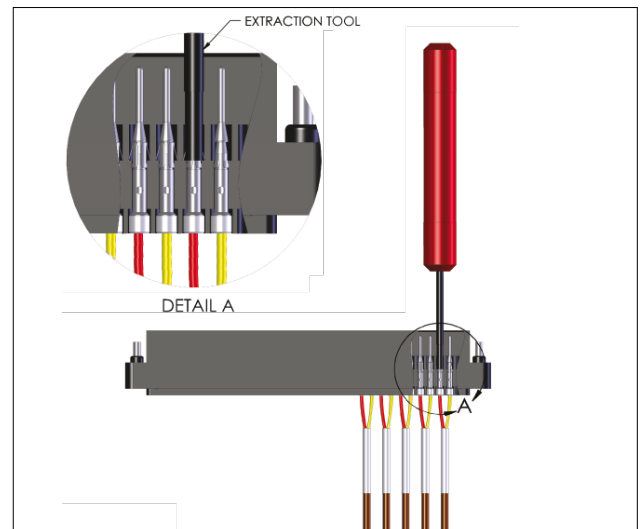

Figure B. Ensure that the tool is kept perpendicular to the module face to avoid damage to the contact or tool.

90 SERIES MODULE INSTALLATION AND REMOVAL

RECEIVER PART # 510104133/ 510104261

ITA PART # 510108124/ 510108245

TOOLS REQUIRED

$\frac{3}{32}$ Allen Wrench

INSTALLATION INSTRUCTIONS

1. Place the module in the receiver or ITA until the upper and lower module screws touch the mating holes in the inner frame. Ensure that Position 1 is located at the top for systems in which the modules are oriented vertically or to the left for systems in which the modules are oriented horizontally.
2. Using a $\frac{3}{32}$ Allen wrench, tighten the top screw 1 to 2 full revolutions, while pushing lightly against the face of the module.
3. Maintain this pressure while tightening the bottom screw 1 to 2 full revolutions.
4. Repeat this sequence until the module is seated. Torque the screw to 4 in-lbs [0.45 Nm].

REMOVAL INSTRUCTIONS

1. To remove, loosen the top screw 1 to 2 full revolutions. Loosen bottom screw 1 to 2 full revolutions.
2. Repeat this sequence until the module is separated from the receiver or ITA.

NOTE: Push or pull the module evenly from the top and bottom to prevent damage to the module.

NOTE: For optimum performance and system longevity, distribute the contact load evenly throughout the module.



Figure A. Receiver Module.

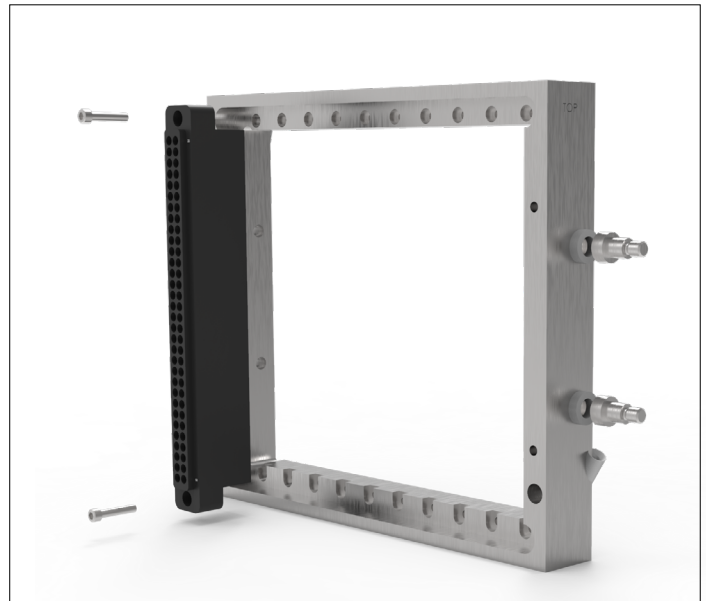

Figure B. ITA Module.

ICON MODULE INSTALLATION AND REMOVAL

RECEIVER PART # 510160110

ITA PART # 510161110

TOOLS REQUIRED

Phillips Head Screwdriver

INSTALLATION INSTRUCTIONS

NOTE: The receiver strain relief plate or the ITA cover may need to be removed prior to installing or removing an iCon module. Please refer to the appropriate User Manual for instructions on how to perform these steps.

1. Place the module in the receiver or ITA until the upper and lower module screws touch the mating holes in the inner frame. Install modules such that Position 1 is located at the top of the ITA/receiver frame.
2. Using a Phillips head screwdriver, tighten the top screw 1 to 2 full revolutions, while pushing lightly against the face of the module.
3. Maintain this pressure while tightening the bottom screw 1 to 2 full revolutions.
4. Repeat this sequence until the module is seated. Torque the screw to 1.5 in-lbs [0.16 Nm].

REMOVAL INSTRUCTIONS

1. To remove, loosen the top screw 1 to 2 full revolutions. Loosen bottom screw 1 to 2 full revolutions.
2. Repeat this sequence until the module is separated from the receiver or ITA.

NOTE: Push or pull the module evenly from the top and bottom to prevent damage to the module.

NOTE: For optimum performance and system longevity, distribute the contact load evenly throughout the module.

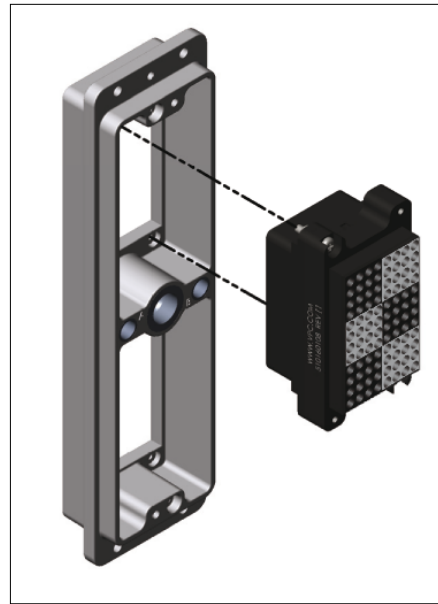

Figure A. Receiver Module.

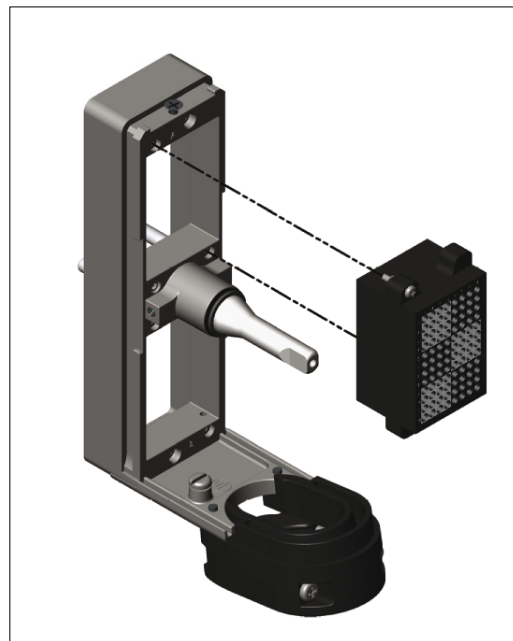
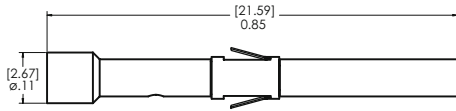
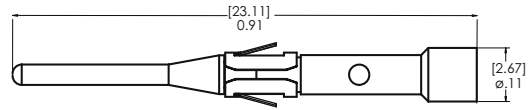

Figure B. ITA Module.

CONTACT PERFORMANCE SPECIFICATIONS



Receiver Contact
Part # 610113131



ITA Contact
Part # 610113133

Dimensions shown: [millimeters]
inches

Electrical Specifications

ANSI TYPE	K
TC TEMPERATURE RANGE	Chromel® and Alumel® -200°C to 1250°C
EMF	-5.97 to +50.63 mV
POLARITY	Chromel® + Alumel® -

Mechanical Characteristics

CYCLE LIFE	20,000
MATING FORCE	4 oz [0.11 kg]

Material

OUTER SHIELD	Base
THERMOCOUPLE PAIR MATERIALS	Chromel® and Alumel®

CROSS REFERENCE TABLES

	STANDARD/ 90 SERIES RECEIVER MODULES		ICON MODULE	CRIMP TOOL	LOCATOR	EXTRACTION
	510104133	510104261				
RECEIVER CONTACTS						
610113131	X	X	X	X	X	X
610113132	X	X	X	X	X	X
610113148	X	X	X	X	X	X
610113168	X	X	X	X	X	X

	STANDARD/ 90 SERIES ITA MODULES		ICON MODULE	CRIMP TOOL	LOCATOR	EXTRACTION
	510108124	510108245				
ITA CONTACTS						
610113133	X	X	X	X	X	X
610113134	X	X	X	X	X	X
610113149	X	X	X	X	X	X
610113169	X	X	X	X	X	X