



9025/ 9025TR USER MANUAL

INDEX (CLICK TO NAVIGATE TO PAGE)

PAGE

- 2 [PRECAUTIONARY NOTES](#)
- 3 [INSTALLING 9025 RACK MOUNT RECEIVER](#)
- 4 [INSTALLING 9025 WITH VERTICAL HINGED MOUNTING FRAME](#)
- 5 [INSTALLING 9025TR WITH SLIDE KIT](#)
- 7 [INSTALLING 9025 WITH SLIDE KIT](#)
- 9 [SLIDE MOUNT NOTATION REGARDING U HEIGHT](#)
- 10 [INSTALLING INSTRUMENT BRACKET](#)
- 11 [INSTALLING KEYBOARD TRAY](#)
- 13 [INSTALLING CABLE TRAY](#)
- 14 [MOUNTING 9025TR TABLETOP RECEIVER](#)
- 15 [REMOVING 9025TR PLATFORM](#)
- 16 [REINSTALLING 9025TR PLATFORM](#)
- 17 [9025TR HANDLE ROTATION & SIDE CHANGE](#)
- 18 [MICROSWITCH REMOVAL & INSTALLATION](#)
- 19 [ITA ENCLOSURES](#)
- 20 [ITA & RECEIVER ENGAGEMENT](#)
- 21 [TROUBLESHOOTING](#)

*Please note that any printed or downloaded User Manual may not reflect the most current revisions.
The information contained herein is subject to change.
For the most current information available, visit vpc.com.*

PRECAUTIONARY NOTES

The following is a listing of precautionary notes that should be noted and followed for optimal equipment operation.

- Never probe a contact without using a mating patchcord as a test lead.
- Never forcefully engage a system if there is an excessive amount of resistance.
- Never allow an ITA to drop as this may cause misaligned engagement and/or irreparable damage.
- Always insert and extract a contact insertion/extraction tool in line with the contact. Never apply pressure to the side as this may break either contact or tool. This also applies to forming and enlarging tools.
- It is advisable that power to the interface system be disconnected prior to handling and maintenance.
- Caution should always be used when engaging, making sure that all foreign objects are removed from the system.
- To prevent equipment damage caused by inadvertent contact being made with the system when not in use; such as bumping into the receiver/ITA assembly with a box, chair or electronic equipment; for example, using ITA and receiver protective covers is highly recommended.



FORCEFUL ENGAGEMENT OF THE ITA AND RECEIVER MAY RESULT IN SERIOUS DAMAGE TO MULTIPLE PARTS OF THE SYSTEM (MODULES, RECEIVER, ITA AND CONTACTS).



IN THE EVENT OF OPERATIONAL DIFFICULTIES, A TRAINED VPC TECHNICIAN SHOULD BE NOTIFIED TO AVOID ANY POTENTIAL DAMAGE TO THE SYSTEM FROM IMPROPER HANDLING.

INSTALLING 9025 RACK MOUNT RECEIVER

PART # 310104420, -114, -331

TOOLS REQUIRED

Phillips Head Screwdriver

INSTALLATION

1. Install clip/cage nuts on rack, to correlate with mounting holes and captive screws on receiver.
2. Place receiver up to clip/cage nuts on rack, making sure they are aligned (**Figure A**).
3. Tighten captive screws in a cross pattern to ensure even torque is applied.

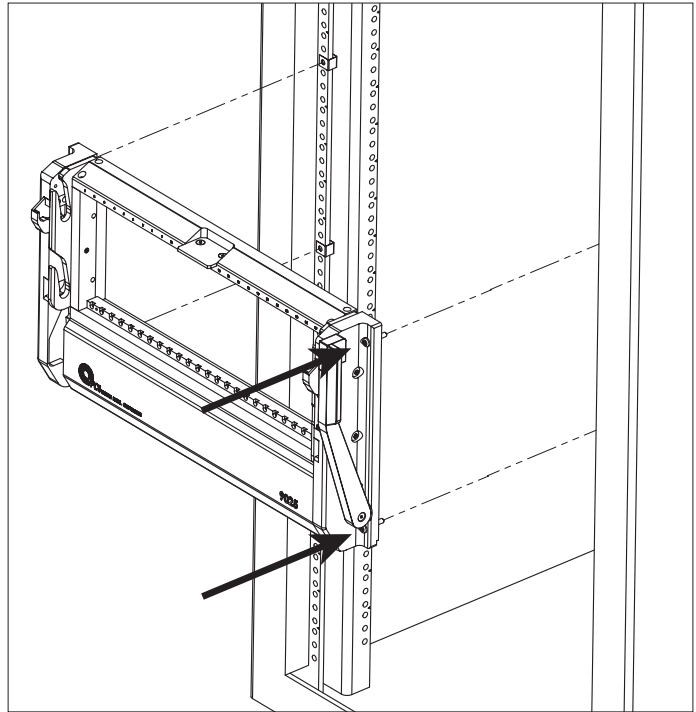

Figure A. Mounting 9025 Receiver.

INSTALLING 9025 WITH VERTICAL HINGED MOUNTING FRAME

PART # 310113316, -320, 310104420, -331

TOOLS REQUIRED

Phillips Head Screwdriver

$\frac{3}{32}$ Allen Wrench

INSTALLATION

1. Using the 4 receiver mounting holes, attach the receiver to the Vertical Hinged Mounting Frame (VHMF) with the 10-32 x 1" captive screws, lock washers, and hex nuts included with the VHMF (**Figures A and B**).
2. Determine an appropriate location in the rack to mount the VHMF and receiver. Keep in mind that the cables connecting to the receiver need to be long enough to allow the VHMF to hinge down.
3. Attach the VHMF to the rack in the desired location using the four 10-32 x 1" mounting screws (**Figure C**). Tighten screws in a cross pattern to ensure even torque is applied.
4. When not in use, ensure that the receiver handle is closed and the VHMF is in the closed position, secured with the two 8-32 screws (**Figure D**).

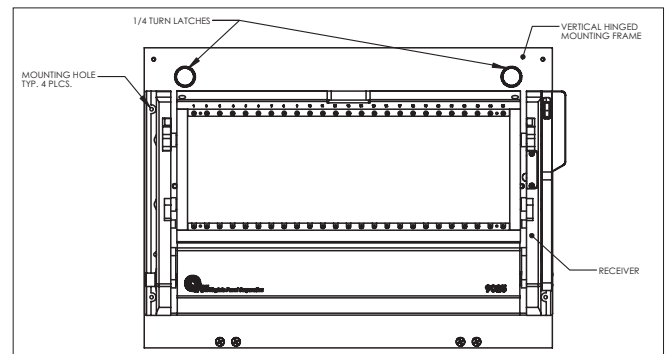

Figure A. Receiver assembled with VHMF.

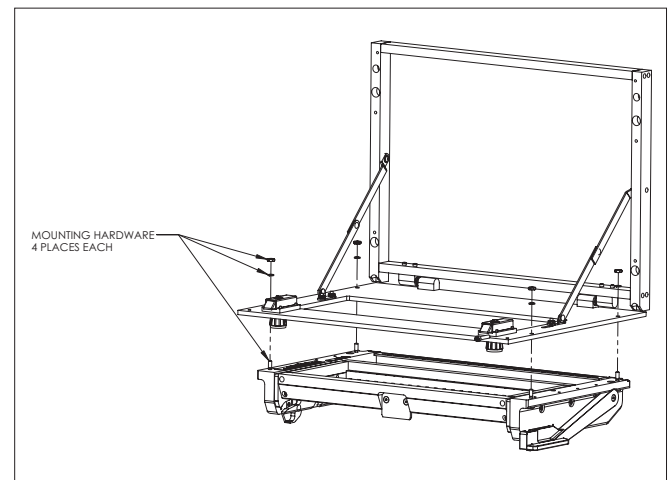

Figure B. Attach receiver to VHMF using provided hardware.

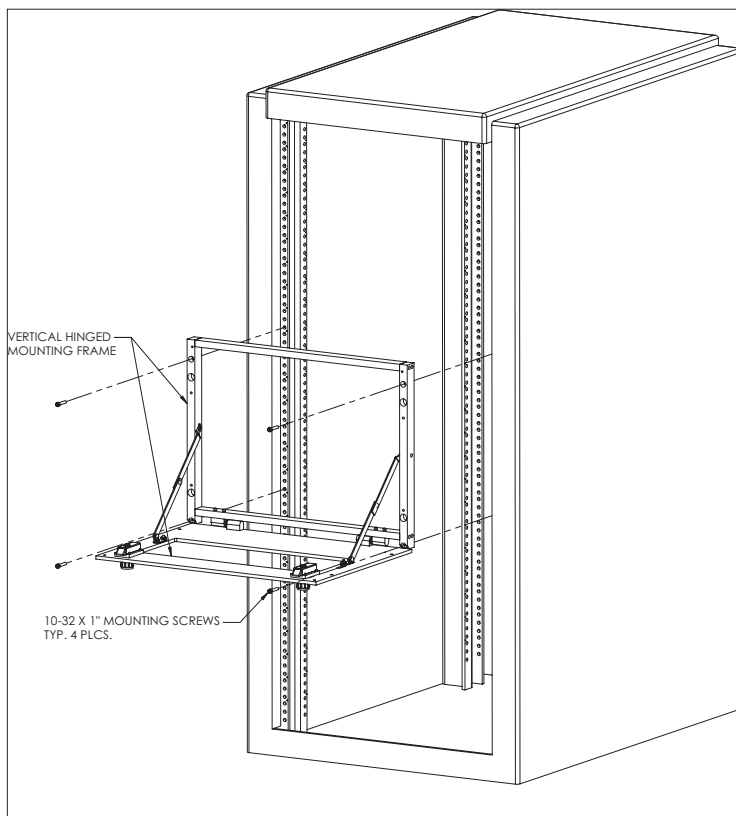

Figure C. Attach the VHMF to the rack.

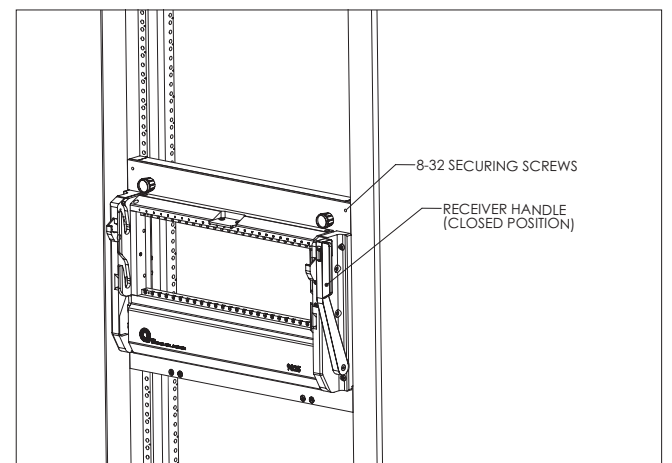

Figure D. Screws secure receiver to rack when not in use.

[RETURN TO INDEX](#)

INSTALLING 9025TR WITH SLIDE KIT

PART # 310104435, 310113411, - 451, -500

NOTE: The receiver platform is estimated to hold 180 lbs. of weight. However, the platform leg kit, is recommended to provide greater stability and balance. The leg kit will allow for weight support of up to 350 lbs. The leg kit may be purchased via [p/n.310113566](https://www.vpc.com/p/n.310113566).

TOOLS REQUIRED

Phillips Head Screwdriver

$\frac{3}{32}$ Allen Wrench

DETERMINE SLIDE KIT LENGTH

1. The slide kit should be chosen based on the distance from rail to rail inside the rack. Measure dimension A to determine the proper slide kit length, ensuring the slide length does not exceed dimensions A + B (**Figure A**).

SLIDE INSTALLATION

1. Determine rack location to mount slides and receiver. Cables will need to be long enough to connect to instrumentation and allow for the slides to fully extend without putting tension on the cables.
2. Install slides using manufacturer's instructions (included with slide packaging or online at [accuride.com](https://www accuride.com)). Make sure to use mounting holes in matching locations on each side. Do not fully tighten down the 4 front and 4 rear mounting screws at this time (**Figure B**).
4. Remove the innermost section of each slide by extending the slides fully, depressing the blue tab, and continuing to extend the inner sections of each slide until it is free from the slide assembly (**Figure C**).
5. If applicable, install the instrument bracket or cable tray onto the inner sections of the slide kit. Following the instrument bracket and/or cable tray Installation instructions also in this manual.

9025TR INSTALLATION

1. Replace each inner slide back into the slide assemblies in the rack.
2. Attach the platform mounting flanges to the inner slide rails using the (6) 8-32 button head screws provided with the receiver (**Figure D**). Do not fully tighten down the screws.
3. Install the 9025TR platform/receiver onto the platform mounting flanges with the (6) 8-32 screws (**Figure E**). Do not fully tighten down the screws.
4. Pull the receiver out as far as possible. The slides will lock in position. Push the blue tabs located on the middle section of the slides. Apply pressure to push the receiver back in toward the rack. The smaller inner slides move into the middle section, which should not move. Push receiver until it backs against the rack.



Dimensions shown: [millimeters]
inches

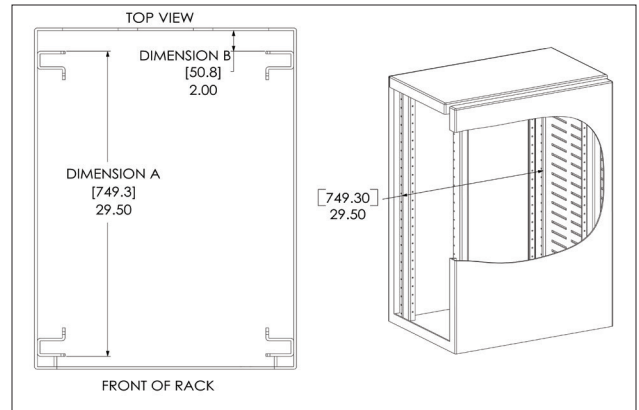

Figure A. Dimensions for measurement.

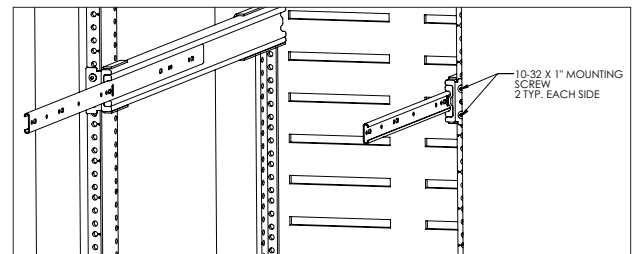

Figure B.

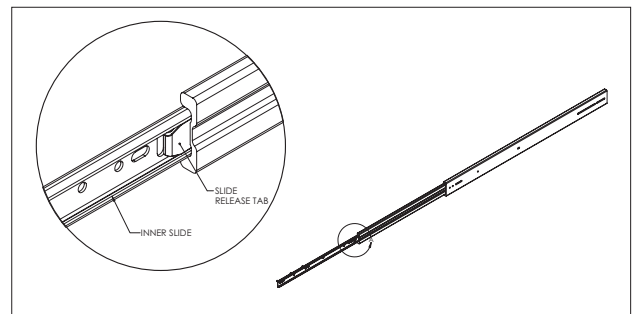

Figure C. Remove inner section of slide from assembly.

INSTALLING 9025TR WITH SLIDE KIT (CONT'D)

PART # 310104435, 310113411, - 451, -500

5. During regular use of the 9025TR, when not extended away from the rack on the slides, the user should secure the receiver to the rack. This prevents the unit from uncontrolled slide motion. To ensure the receiver is correctly aligned with mounting hole locations on the test rack, temporarily fasten the receiver to the rack using its captive 10-32 screws. Be sure to provide support beneath the platform, lifting it slightly to ensure an even screw engagement (**Figure F**).
6. Now, complete installation by fully tightening the previously installed screws in this order:
 1. 8-32 platform mounting screws (**Figure D**).
 2. 8-32 button head platform mounting flange screws (**Figure C**).
 3. Front slide mounting screws (from slide mounting procedures).
 4. Rear slide mounting screws (from slide mounting procedures).
7. With the remaining installation screws now secure, you may release the receiver and platform from the rack by unscrewing the 10-32 captive screws. Slowly slide the receiver out.
8. To ensure proper support when extending the receiver and platform away from the rack, stop the receiver and platform at approximately 6" from the rack.
9. Reach around to the rear of the receiver to the slides underneath on both sides. Manually extend the middle section of the slides forward until fully underneath the platform. The receiver and platform may then be extended while holding this middle slide in place. If completed properly, the middle section of the slides will remain underneath the platform and offer the strongest support.



ALWAYS SUPPORT THE RECEIVER AND PLATFORM WITH THE MOST ROBUST (MIDDLE) SECTION OF THE SLIDES.

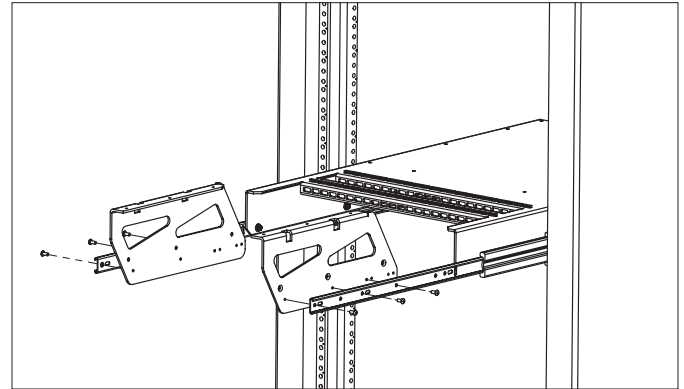

Figure D. Attach platform mounting flanges to the inner slide rails.

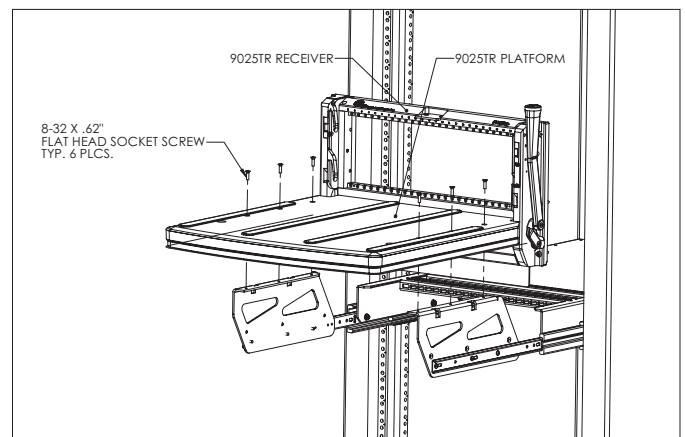

Figure E. Install 9025TR onto platform mounting flanges.

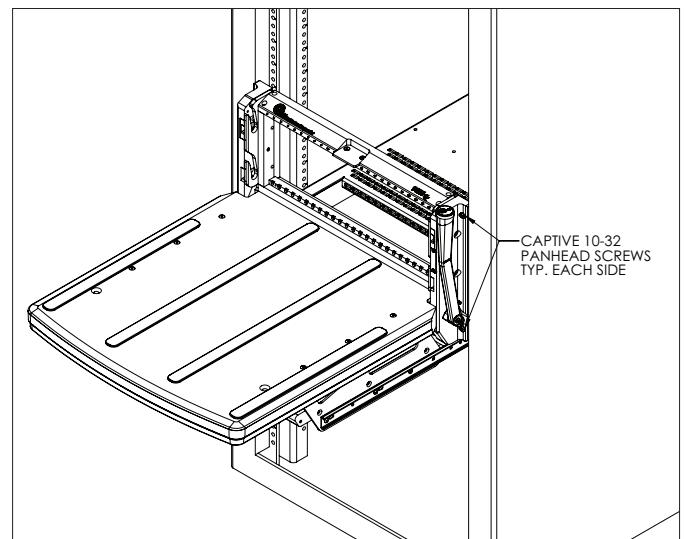

Figure F. Secure the receiver to the rack with the captive 10-32 screws, taking care to lift up on the platform slightly to ensure even engagement.

[RETURN TO INDEX](#)

INSTALLING 9025 WITH SLIDE KIT

PART # 310104437, -498, 310113409, -451, -500

TOOLS REQUIRED

- Phillips Head Screwdriver
- ³/₃₂ Allen Wrench

DETERMINE SLIDE KIT LENGTH

- The slide kit should be chosen based on the distance from rail to rail inside the rack. Measure dimension A to determine the proper slide kit length, ensuring the slide length does not exceed dimensions A + B (**Figure A**).



SLIDE INSTALLATION

- Determine rack location to mount slides and receiver. Cables will need to be long enough to connect to instrumentation and allow for the slides to fully extend without putting tension on the cables.
- Install slides using manufacturer’s instructions (included with slide packaging or online accuride.com). Make sure to use mounting holes in matching locations on each side. Do not fully tighten down the 4 front and 4 rear mounting screws at this time (**Figure B**).
- Remove the innermost section of each slide by extending the slides fully, depressing the blue tab, and continuing to extend the inner sections of each slide until it is free from the slide assembly (**Figure C**).
- If applicable, install the instrument bracket and/or cable tray onto the inner sections of the slide kit. Following the instrument bracket and/or cable tray installation instructions also in this manual.

Dimensions shown: [millimeters] inches

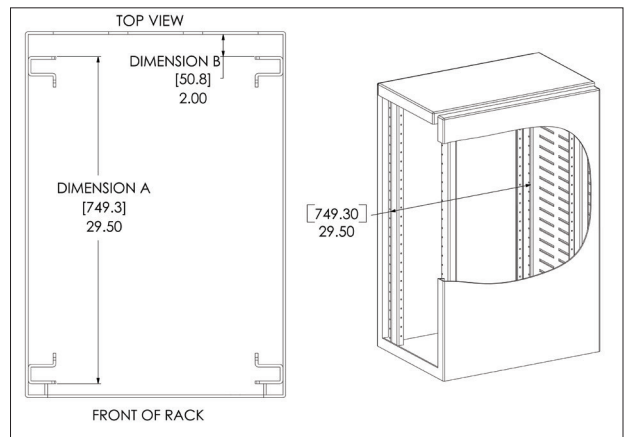

Figure A.

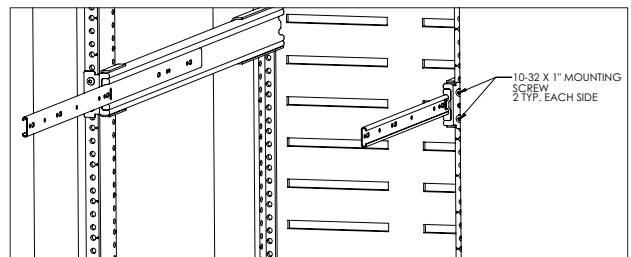

Figure B. Slides installed into rack.

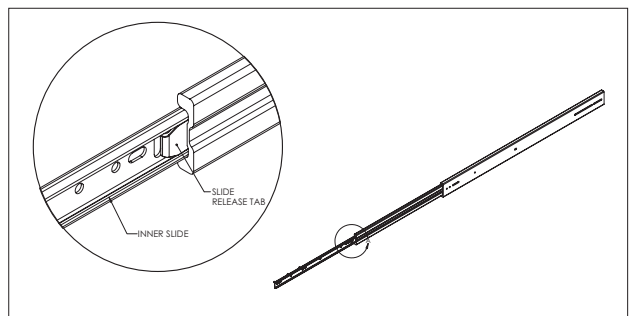

Figure C. Remove inner section of slide from assembly.

INSTALLING 9025 WITH SLIDE KIT (CONT'D)

PART # 310104437, 310113409, - 451, -500

9025 INSTALLATION

1. Attach each receiver mounting flange to the appropriate slide using the provided (3) 8-32 button head screws, per side. Ensure that the mounting surface portion of the flange is directed toward the outside of the overall assembly (**Figure D**).
2. Re-install the inner slide assembly into the rack by aligning each inner slide with the slide assembly in the rack (**Figure E**). With the inner section inserted into the center section of the slide assembly, push the mounting flanges toward the rack, collapsing the slides. It may be necessary to depress the locking tabs, if the slides are locked in the extended position.
3. Slide the assembly out to enable access to the mounting flanges.
4. Using the provided (8) 8-32 flat head screws, attach the receiver to the mounting flanges (**Figure F**).

NOTE: When moving the rack or attaching an ITA, ensure the slides are fully collapsed and receiver is secured to rack with .190-32 UNF screws.

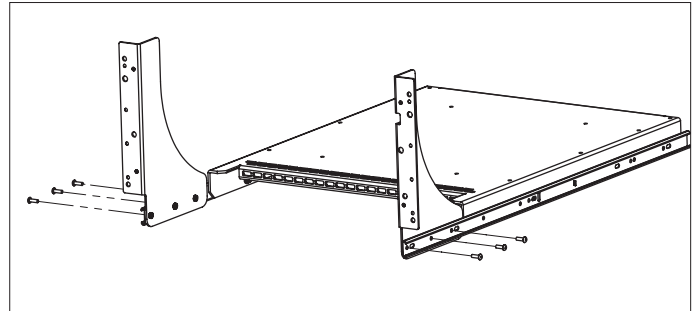

Figure D. Be sure the mounting surface of the flange is facing out.

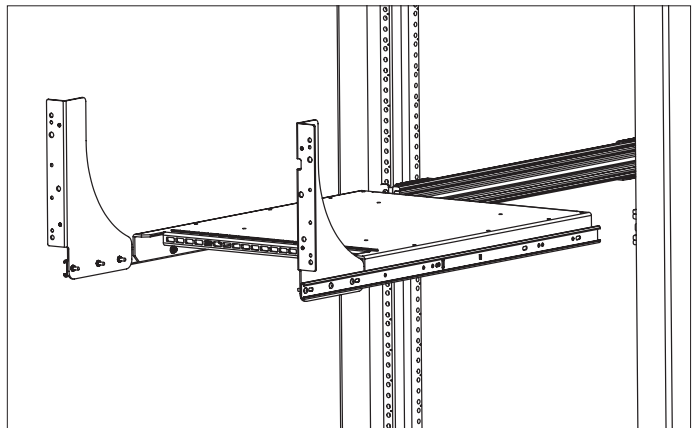

Figure E. Seen here with optional instrument bracket installed.

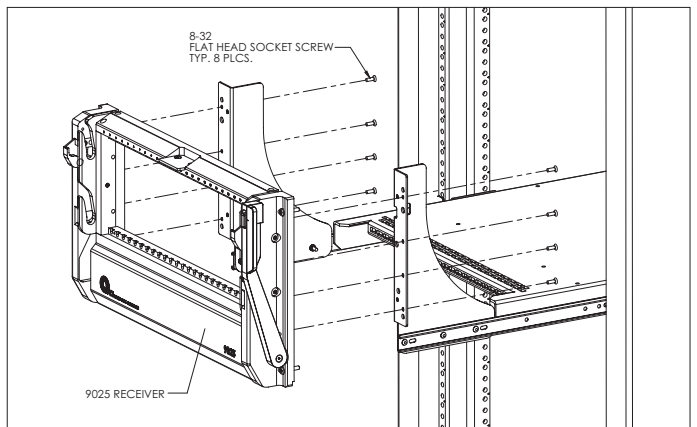

Figure F. Seen here with optional instrument bracket installed.

SLIDE MOUNT NOTATION REGARDING U HEIGHT

PART # 310104363, -387, -437

With certain receivers including the 9025/ 9025TR, the slide mechanism protrudes downward slightly into the next U height on both sides of the receiver. Please make any necessary adjustments to U height when planning your test rack layout.

Measurements can vary per receiver, see table.

Part Number	DIM A
310 104 363	.25 [6.4]
310 104 374	.46 [11.7]
310 104 379	.46 [11.7]
310 104 387	.46 [11.7]
310 104 437	.46 [11.7]
310 104 462	.46 [11.7]

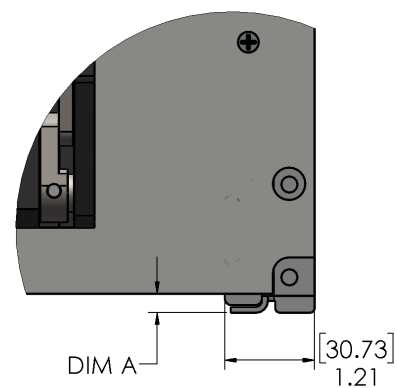
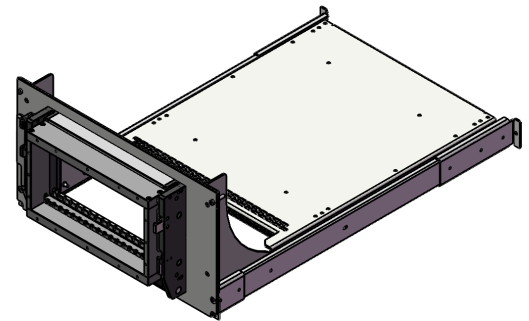
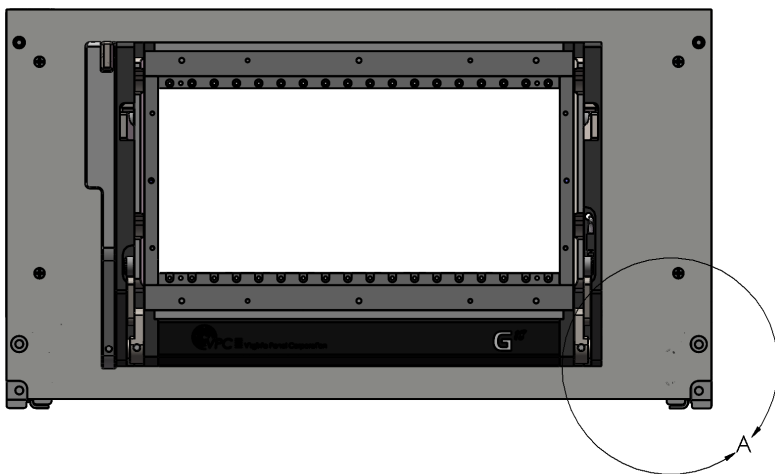

DETAIL A
SCALE 1 : 1

INSTALLING INSTRUMENT BRACKET

PART # 310113453

NOTE: This instrument bracket is only compatible with slide kits 28" and longer.

TOOLS REQUIRED

$\frac{5}{32}$ Allen Wrench
Phillips Head Screwdriver

INSTALLATION

- Depress the blue tab on one of the inner slides and remove from outer slide.
- Attach it to the instrument bracket using (2) 8-32 button head screws in the front two holes. The front two holes on the instrument bracket will align with the front two holes on any length slide kit.
- Install the third 8-32 button head screw in the rear hole of the inner slide and instrument bracket. **(Figure A)** The third hole alignment may differ depending on which slide kit you are using.
- Attach the remaining inner slide to the other side of the instrument bracket.
- Reinstall the inner slides to the rack installed slides.
 - Slide the left mid-section of the slide all the way out, you will feel it lock into position.
 - Feed the matching inner slide into position and ensure the inner section slides into place with the roller bearings seated in the groove.
 - Push the inner slide in about 6-8 inches and then pull out the right side. Slide the track of the mid-section over the right side of the inner slide.
 - Pull the slide out until the position matches the left side.
 - Reach to the back of the middle slides and release the spring locking mechanism **(Figure B)**.
- At this time, both sides should be partially installed. This is indicated when neither side is able to proceed into the rack because the support tab on the instrument brackets is hitting the slide mounting bracket.
- Rotate both instrument brackets inward so the support tabs can pass the mounting brackets. Push and install both slides simultaneously into position. Be sure to push in the blue tabs to allow the inner tabs to travel into the middle slide section.

NOTE: The middle section will not go into the outer section until the inner section has been fully installed into the middle section.

- Tighten the slide mounting screws.



MAKE SURE ALL MOUNTING SCREWS HAVE BEEN SECURELY TIGHTENED. ONLY USE 8-32 BUTTON HEAD SCREWS.

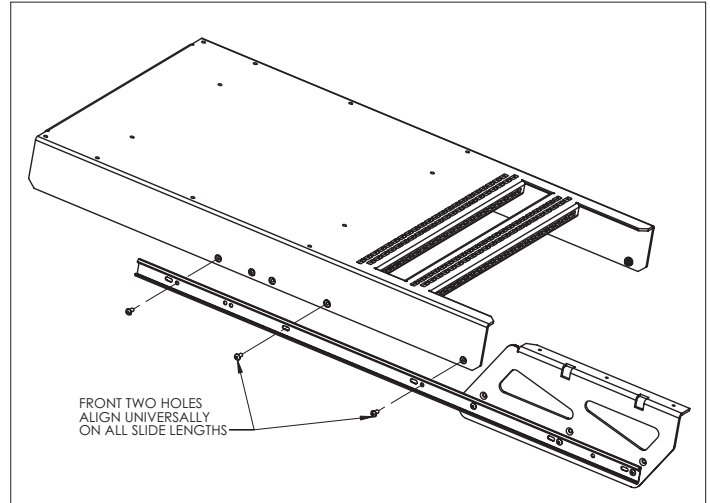
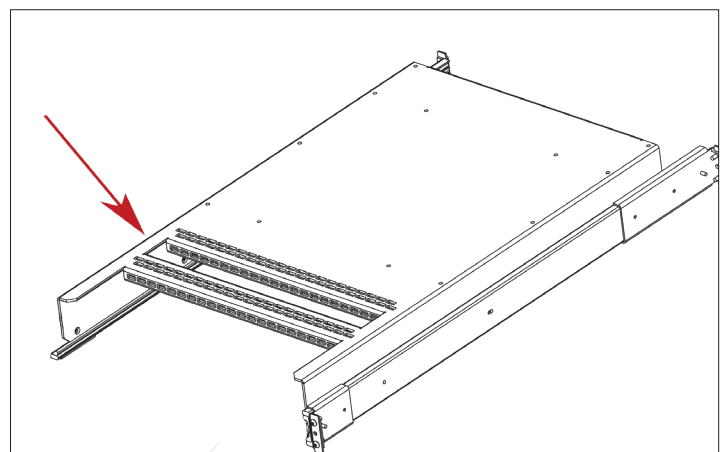

Figure A. Shown here, 30" slide kit (Part # 310 113 411).



Figure B. Spring-locking mechanism.



The slots on the instrument bracket are designed to accept a strap for securing a test chassis, if desired.

INSTALLING KEYBOARD TRAY

PART # 310113439

NOTE: The Keyboard Tray Kit mounts below the platform on the slide-mounted 9025TR receiver. The kit includes a keyboard with touch pad and 72" long USB connector, keyboard tray, and 12" slides.

TOOLS REQUIRED

3/32 Allen Wrench



Dimensions shown: [millimeters]
inches

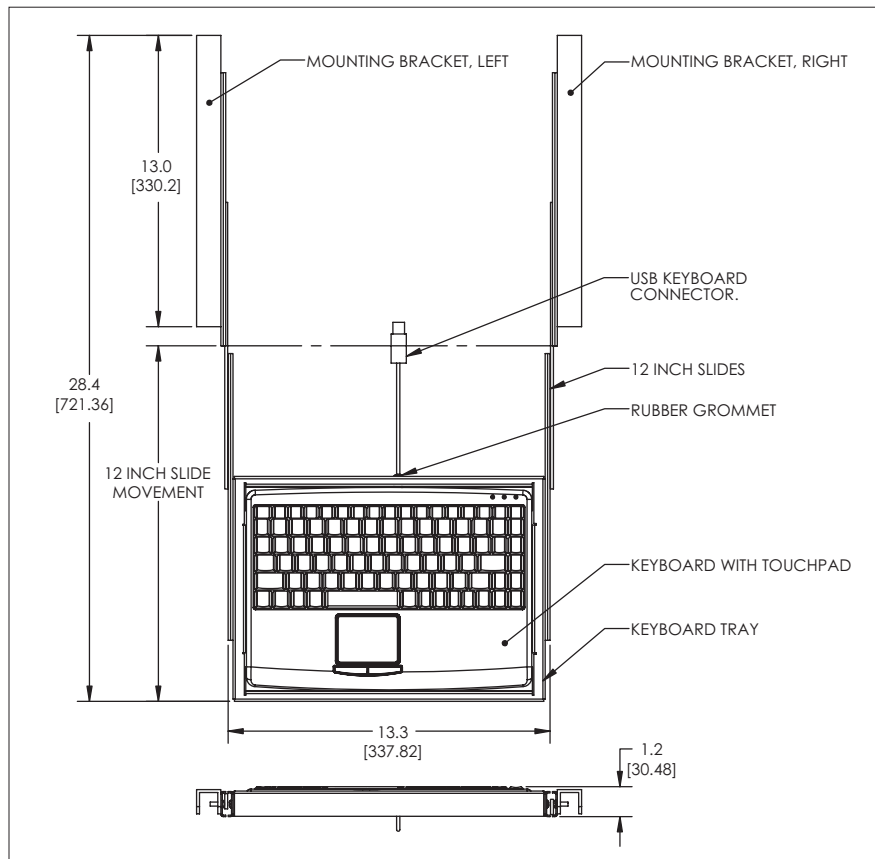

Figure A.

INSTALLING KEYBOARD TRAY (CONT'D)

PART # 310 113 439

1. Attach the keyboard mounting brackets to the existing platform mounting brackets using with the supplied 8-32 flat head screws, nuts, and lock washers. Align the keyboard mounting brackets with the 3 screws that extend beyond the platform mounting bracket (**Figure A**).
2. Use 6 of the 8-32 x .38 button head screws to attach the 12" keyboard kit slides to the inner side of the keyboard brackets. The manufacturer stamped identification on the slides should be placed toward the rack. Fully extend the keyboard slides to access the hole locations (**Figure B**).
3. Insert the keyboard into the keyboard tray. Wrap the plastic strain relief around the cable near the back of the keyboard and press into the hole provided on the keyboard tray.
4. Fully extend the 12" slides and mount the keyboard tray (**Figure C**). Floating, self-locking fasteners in the keyboard mounting brackets prevent the screws from backing out. This creates a noticeably snug fit when tightening the screws.

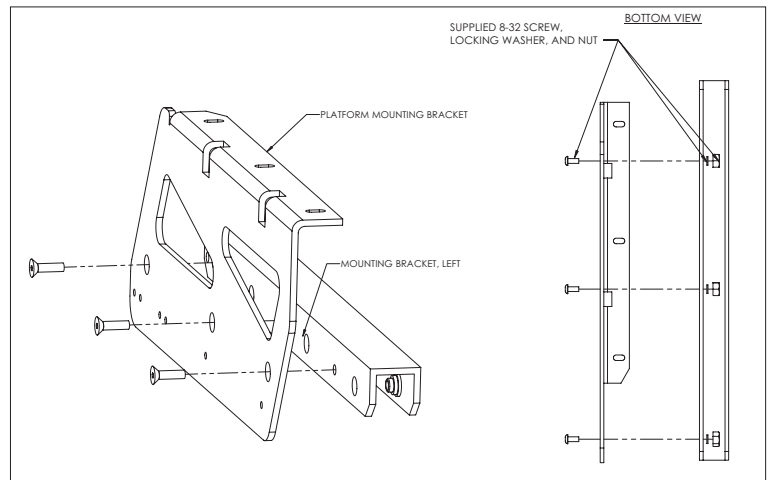

Figure A.

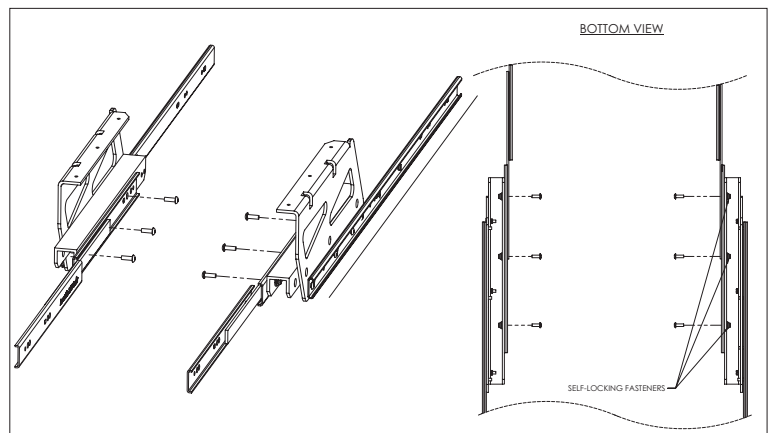

Figure B. Fully extend the keyboard slides to access the mounting holes for the self-locking fasteners.

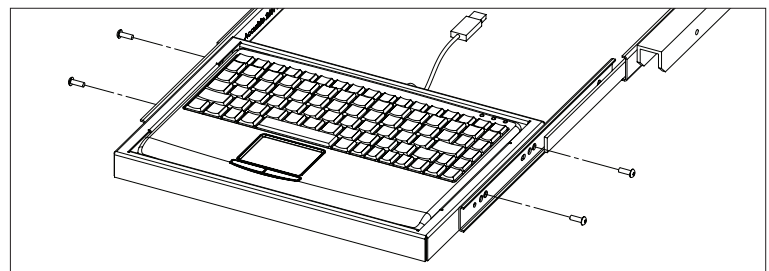
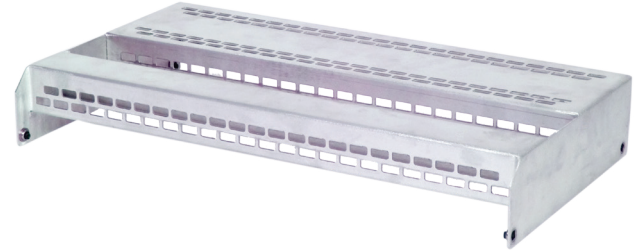

Figure C. The different hole patterns allow for variations in the overall position of the keyboard.

INSTALLING CABLE TRAY

PART # 310113424

NOTE: The cable tray is only compatible with slide kits 28" and longer. Cable trays cannot be used in conjunction with instrument brackets.



TOOLS REQUIRED

$\frac{3}{32}$ Allen Wrench

1. Loosen the slide mounting screws by one turn.
2. Depress the blue tabs and remove the inner slides.
3. Attach the cable tray to the inner slides with the provided 8-32 screws (**Figure A**).
The angled side of the cable tray should face the receiver.

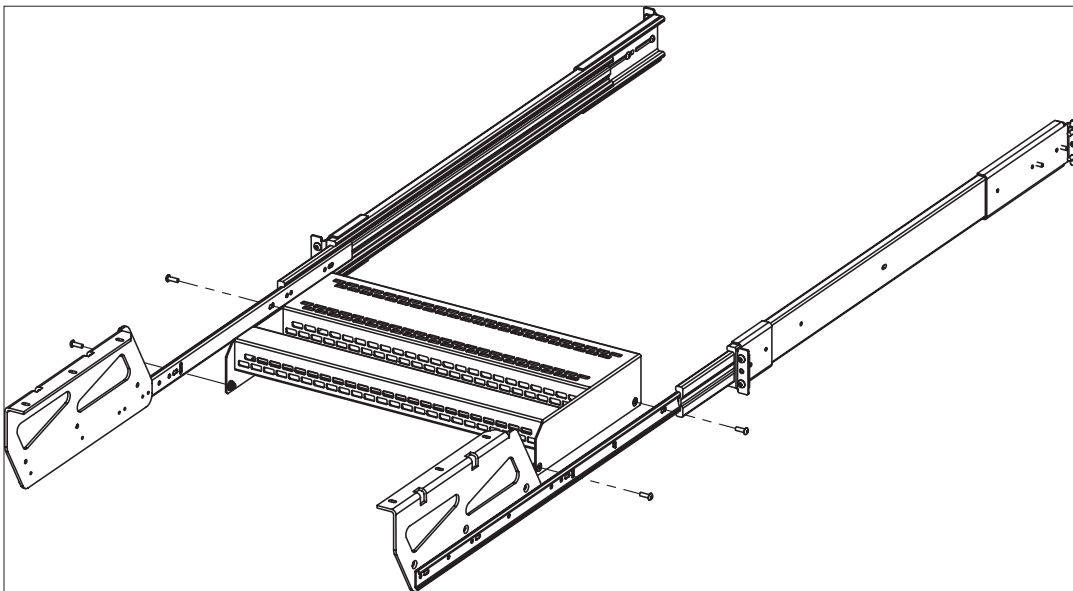

Figure A.

4. Reinstall the inner slides and cable tray assembly into the rack.
5. Retighten the slide mounting screws.

MOUNTING 9025TR TABLETOP RECEIVER

PART # 310104436

NOTE: The 9025TR Tabletop Receiver includes a rear cover to protect receiver side wiring and a “skirt” to allow for sufficient rotation of the handle.

PERMANENT MOUNTING

1. Prepare the mounting surface using the following dimensions:
 - Receiver without rear cover installed- drill 0.257” [6.53 mm] minimum thru holes (**Figure A**).
 - Receiver with rear cover installed- drill 0.196” [4.98 mm] minimum thru holes (**Figure B**).
2. Secure the receiver skirt to the mounting surface with the provided ¼-20 x 1.00 screws, washers and nuts.
3. Use the 3/32 Allen wrench with the provided #8-32 screws and washers to attach the included rear cover to the receiver.
4. Secure the rear cover to the mounting surface with the provided 10-32 x .375 screws, washers and nuts (**Figure B**).

Dimensions shown: [millimeters]
inches

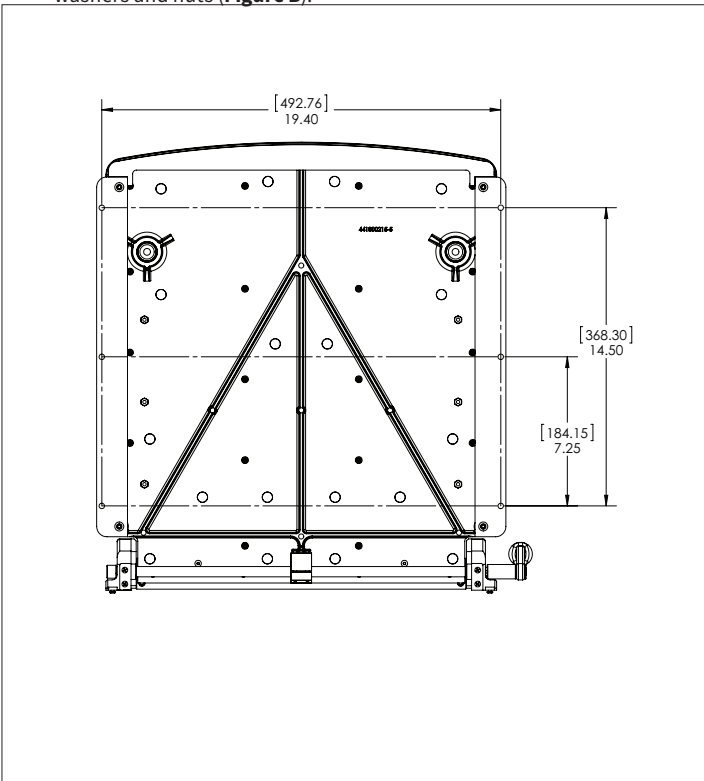

Figure A. Receiver without Rear Cover Installed.

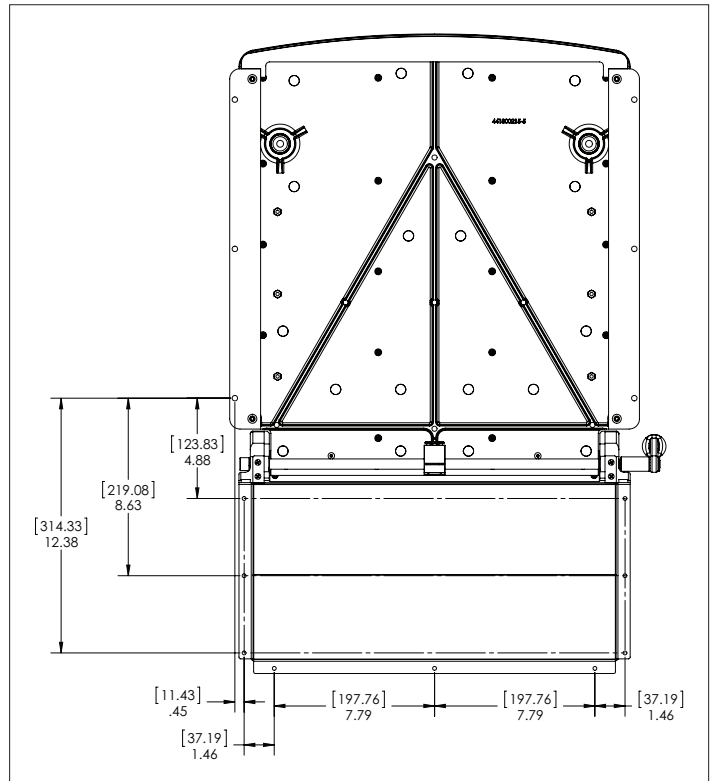

Figure B. Receiver with Rear Cover Installed.

REMOVING 9025TR PLATFORM

PART # 310104435

TOOLS REQUIRED

- 5/32 Ball End Allen Wrench or Ball Driver
- Phillips Head Screwdriver
- Zip Ties

REMOVAL

1. Secure receiver to rack using the captive 10-32 mounting screws (**Figure A**). The platform should only be removed from the receiver after the receiver has been secured to the rack.
2. Remove any optional accessories including keyboard tray, leg kit and instrument bracket.
3. Remove the torsion shaft cover by removing the two flat head Phillips screws on each end and the three pan head Phillips screws in the center of the cover.
4. *With the receiver secured to the rack*, remove the (6) 8-32 mounting screws from the bottom of the 9025TR to remove the platform (**Figure B**).
5. Remove the 8-32 screws that attach the platform brackets to the slides. The platform will now be free from the receiver and slides. The platform brackets do not need to be removed from the platform for transportation.
6. To secure the slides for transport, return the slides to the closed position and use zip ties to secure the 3 sections of each slide.

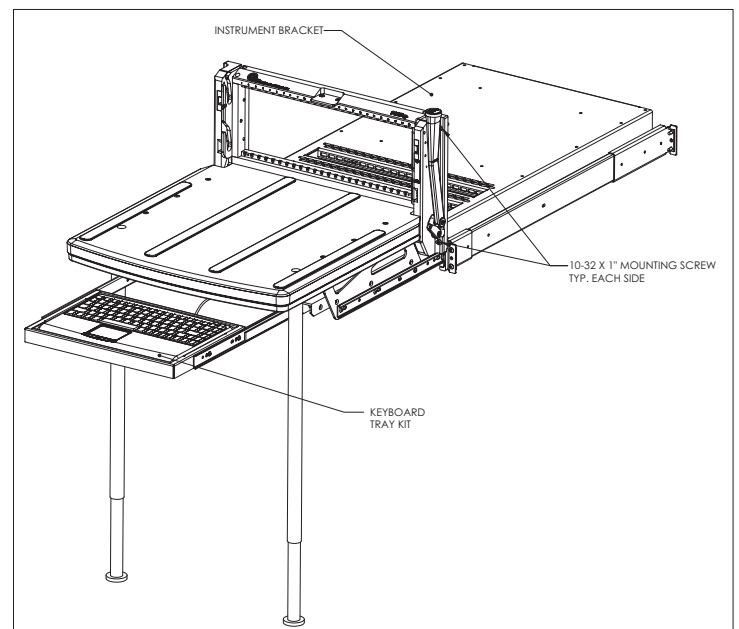

Figure A.

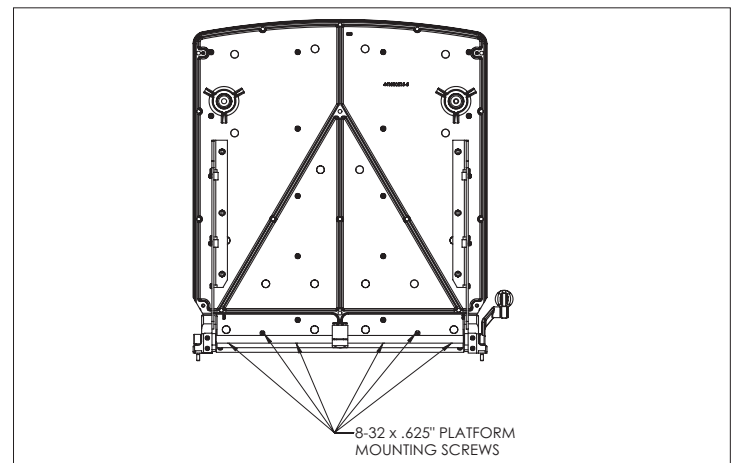

Figure B. The 6 mounting screws must be removed from the receiver before the platform can be removed.

[RETURN TO INDEX](#)

REINSTALLING 9025TR PLATFORM

PART # 310104435

REINSTALLATION

1. Remove zip ties used to secure the slides.
2. Pull the slides out from the closed position.
3. Attach platform with brackets to the slides using the (6) 8-32 mounting screws (**Figure C**).
4. Attach the torsion shaft cover by inserting the two flat head Phillips screws on each end and the three pan head Phillips screws in the center of the cover.
5. Slide the platform to the slide's closed position and install the six 8-32 mounting screws to attach the platform to the 9025TR receiver.
6. Re-install any optional accessories.
7. Once the platform has been re-attached to the 9025TR and the slides, remove the receiver from the rack by releasing the captive 10-32 mounting screws.

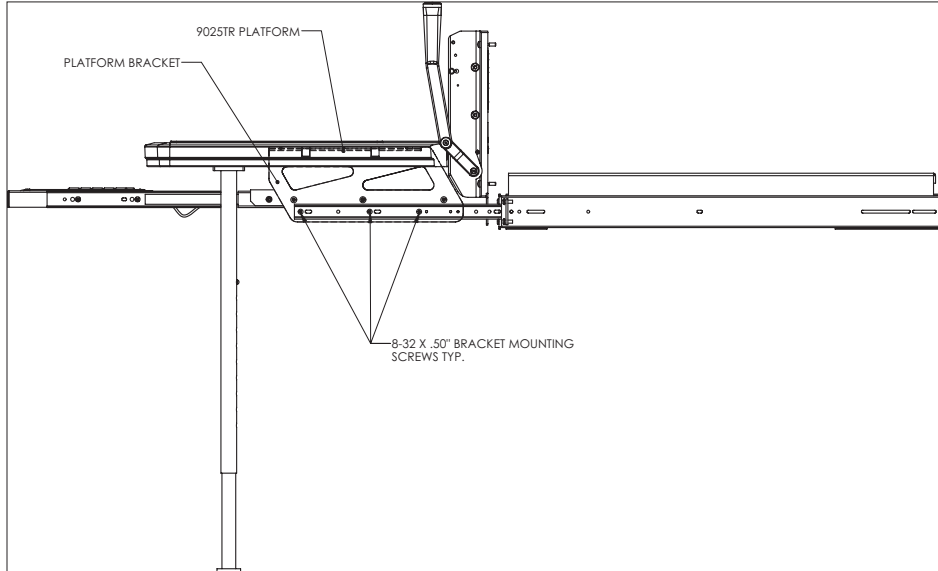

Figure C. The brackets will be securely reinstalled to the slides after the mounting screws are installed.

9025TR HANDLE ROTATION AND SIDE CHANGE

PART# 310104435

Dimensions shown: [millimeters]
inches

NOTE: The 9025TR receiver handle requires approximately 90° of counter-clockwise movement space for engagement and 90° of clockwise movement space for disengagement of the ITA. The handle is removable and adjustable to accommodate different mounting configurations and for transportation purposes.

TOOLS REQUIRED

$\frac{3}{32}$ Allen Wrench

ROTATION

1. Remove the handle screw with the Allen wrench.
2. Remove the handle and reposition in 90° increments (**Figure A**).
3. Replace the screw and tighten until the handle is secured tightly.

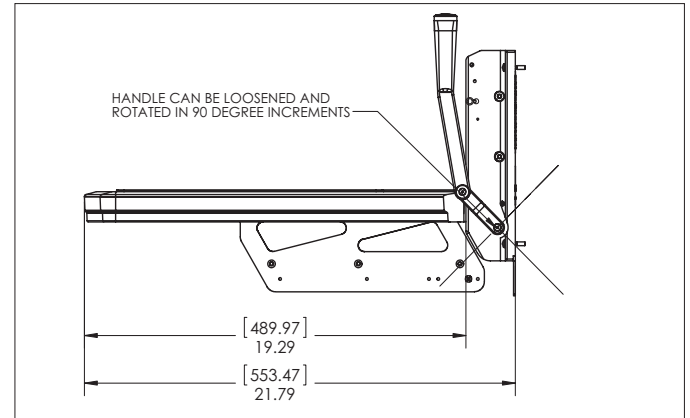

Figure A.

SWITCHING HANDLE SIDES

1. Using the Allen wrench, remove the handle screw and handle (**Figure B**).
2. Using the Allen wrench, remove the screw and handle washer on the left side of the receiver (**Figure B**).
3. Install the handle into the left side hole at the preferred 90° position (**Figure C**).
4. Replace the screw and handle washer into the cavity on right side of the receiver.

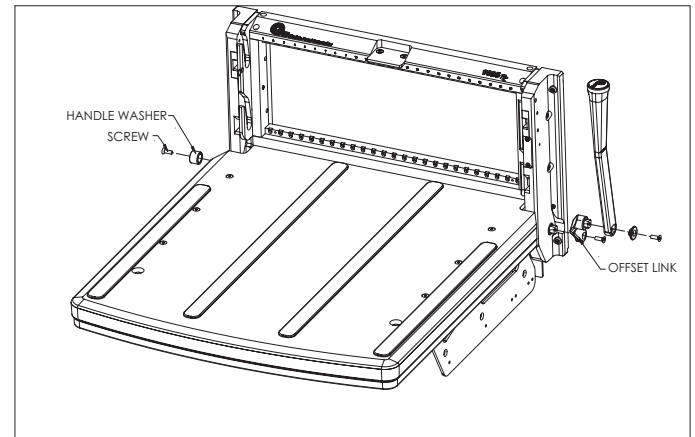

Figure B. Remove handle from standard right side.

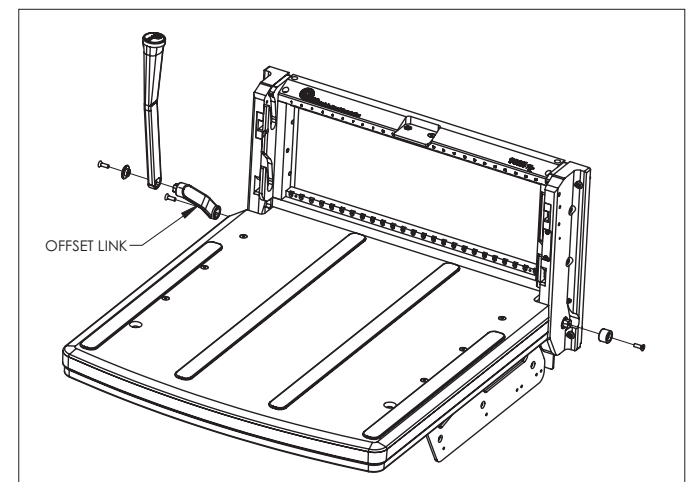

Figure C. Install handle on left side.

[RETURN TO INDEX](#)

MICROSWITCH REMOVAL AND INSTALLATION

PART # 310113200

NOTE: A microswitch may be used in VPC receivers to determine the presence (or absence) of an engaged ITA in the system. It is typically configured so that power to the interface is turned off when there is no ITA present.



AS WITH ALL ELECTRICAL SYSTEMS - DISCONNECT ALL ELECTRICAL SUPPLIES TO THE SYSTEM PRIOR TO REMOVAL OF THE MICROSWITCH.



TOOLS REQUIRED

Phillips Head Screwdriver

REMOVAL

1. Disengage and completely remove the ITA from the receiver.
2. With the receiver handle in the open position (handle down), unscrew the two plate retaining screws (using a Phillips screwdriver) that are located immediately below the top right engaging mechanism/slot - this will expose the microswitch.
3. Remove any modules necessary to access the microswitch retaining screws.
4. Using a Phillips screwdriver, unscrew the retaining screws. Caution should be taken to ensure that no screws fall into the system.
5. The microswitch may now be removed for continuity testing or replacement.

INSTALLATION

Repeat above steps in reverse order.

MICROSWITCH COLOR CODE:

Wires- 24 AWG
Red - Normally Closed
White - Normally Open
Black - Common

ITA ENCLOSURES

PART # 410112198, -273, -823, 410104104, -111, -306

TOOLS REQUIRED

Front mount: $\frac{3}{32}$ Allen Wrench for 4-40 screws

Rear mount: $\frac{7}{64}$ Allen Wrench for 6-32 screws

Phillips Head Screwdriver

STANDARD ENCLOSURES

- To mount ITA frame, align frame with enclosure.
- Insert screws and tighten with Allen Wrench (**Figure A**).
 - Torque 6-8 in. lbs. for 4-40 screws (front mount)
 - Torque 10 in. lbs. for 6-32 screws (rear mount)

NOTE: When using *Sloped ITA Enclosure p/n 410114004 (15" depth)*:

- Due to the depth and probable weight of this enclosure, VPC recommends use of this enclosure with the TR model of the 9025 (platform).
- When using this enclosure to mate with a standard 9025 Receiver (non-TR/platform), ITA p/n 410104260 with 2" depth must be used for proper clearance.

CUSTOMIZED 9025TR ENCLOSURES

- When building a customized ITA enclosure, these guidelines should be followed to ensure proper function of the 9025TR Receiver:
 - When mounting, the ITA frame must be flush with the bottom of the enclosure
 - The width of the enclosure may longer than the ITA frame, as long as the extended width is offset to the opposite side of the receiver's engagement handle
 - There is no limit to the height of the enclosure.

Dimensions shown: [millimeters]
inches

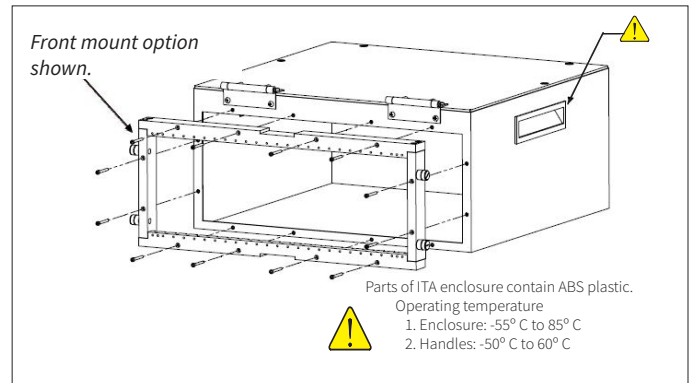
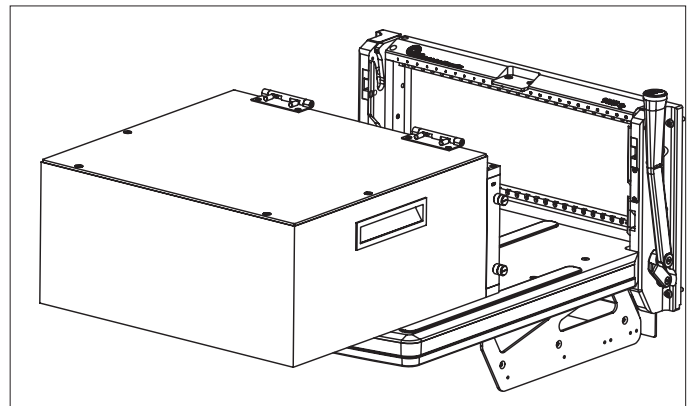

Figure A. Example -p/n 410112823



9025TR with Standard ITA Enclosure

ITA AND RECEIVER ENGAGEMENT

Prior to engaging an ITA with the receiver for the first time, ensure all modules (ITA and receiver) are properly installed. This includes inspection of modules to ensure proper mounting and to verify module positioning. Modules must be installed so that Pin 1 of each respective mating receiver and ITA module pair are adjacent. VPC recommends that Pin 1 be positioned to the left in the receiver and ITA frames. All ITA modules must match the respective receiver modules. It is crucial for all modules to be installed properly.

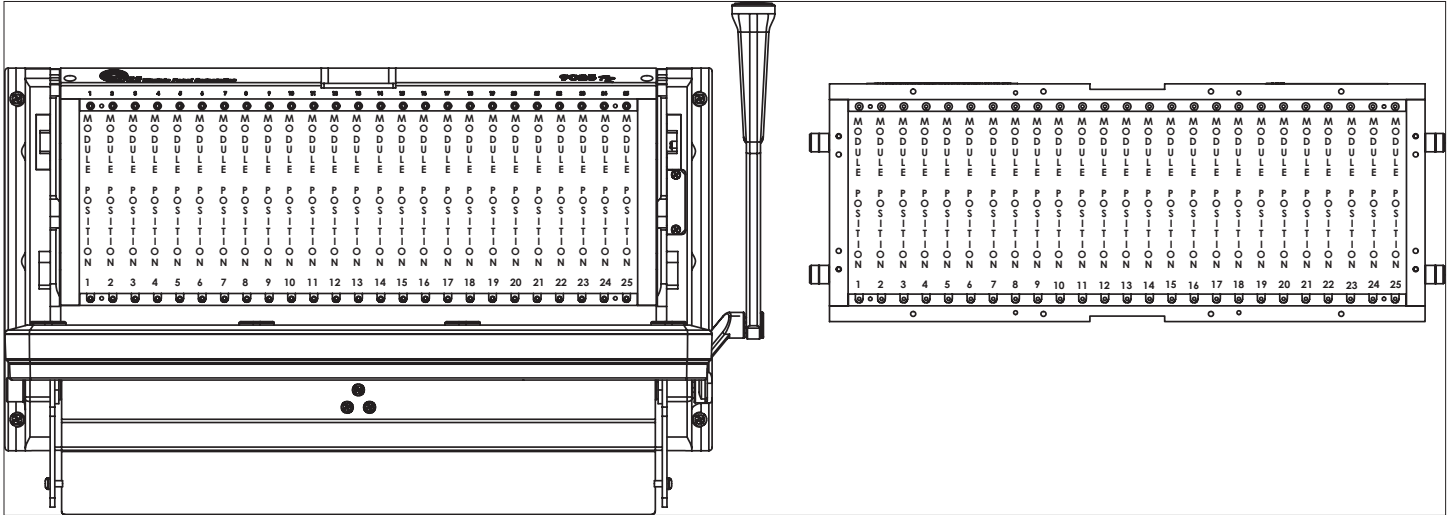

Figure A. 9025 Receiver and ITA.

ENGAGEMENT

1. The receiver should be checked for any foreign objects that may interfere with engagement.
2. After inspection, the ITA is ready for engagement with the receiver. The ITA may be placed onto the receiver platform and properly positioned relative to the receiver guide pins. Ensure that the ITA roller bearings are aligned with the receiver slide openings when the receiver handle is in the open position.
3. Carefully rotate the handle forward to actuate the receiver slide engagement mechanisms, which will draw the ITA into engagement position with the receiver. Once the handle reaches a positive stop at the end of its travel and latches into place, the modules are engaged.
4. Upon completing use of the ITA, rotate the receiver handle to the open position, remove the ITA, reinstall the receiver protective cover and rotate the handle to the closed position.
5. Always protect the contacts when the system is not in use. The receiver contacts are protected when either the ITA or receiver protective cover is engaged. VPC recommends use of both receiver and ITA protective covers to avoid potential contact damage.



IMPROPER INSTALLATION WILL DAMAGE THE MODULES, AND POSSIBLY THE ITA AND/OR RECEIVER.



IN THE EVENT OF COMPLICATIONS, A TRAINED TECHNICIAN SHOULD BE NOTIFIED IMMEDIATELY TO AVOID ANY DAMAGE TO THE SYSTEM. THIS APPLIES TO ANY DIFFICULTIES THAT MAY BE EXPERIENCED DURING ENGAGEMENT.

TROUBLESHOOTING

ITA will not properly engage with receiver.

ITA is possibly out of alignment or module are mismatched.

- Remove and inspect the ITA for proper alignment.
- Check for foreign objects/tools obstructing mating.
- Inspect module configuration. Ensure ITA module placement and type match that of each receiver module.
- Inspect for any bent or incorrectly placed pins.
- Verify the orientation of the receiver and ITA modules.

Excessive force is needed to engage the handle.

(Typical contact load- approximately 35 lbs. force)

ITA is possibly out of alignment or module are mismatched.

- See above troubleshooting steps

ITA will not engage with the receiver after attempting above troubleshooting steps.

Contact VPC – unauthorized user adjustments to the system will void the warranty.

No continuity upon engagement.

- When replacing an ITA contact, the mating contact on the receiver side should also be inspected and replaced if necessary.
- Check wiring and replace if necessary.
- Contact not secured in module.
- Contact damage. Visually inspect all contacts for damage to potentially isolate damaged pin prior to checking for continuity with a multi-meter.

A “short ” in the wiring upon engagement.

- Damaged contact(s) may cause high resistance. Upon replacing a contact in the ITA, the mating contact on the receiver side should also be inspected and replaced, if necessary.
- Check wiring and replace, if necessary.

Receiver and ITA will not disengage.

Engagement mechanism within the receiver may be faulty.

Contact VPC – unauthorized user adjustments to the system will void the warranty.

Handle feels/appears loose.

- Refer to drawing for tightening instructions:

