



D1 USER MANUAL

INDEX ([CLICK TO NAVIGATE TO PAGE](#))

PAGE

1 [RECEIVER PART IDENTIFICATION](#)

2 [ITA PART IDENTIFICATION](#)

3 [RECEIVER AND ITA ENGAGEMENT](#)

4 [RECEIVER MOUNTING](#)

5 [MODULE INSTALLATION AND REMOVAL](#)

6 [STRAIN RELIEF ASSEMBLY](#)

*Please note that any printed or downloaded User Manual may not reflect the most current revisions.
The information contained herein is subject to change.
For the most current information available, visit vpc.com.*

RECEIVER PART IDENTIFICATION

PART # 310131102

IDENTIFICATION

1. Locate the frame without guide pins or blue bushings. This is the receiver frame.
2. Rotate the receiver until the in-set face of the frame is visible (**Figure A**). Note the two mounting screw holes in the interior of the receiver. This is the module installation side. Any wiring will be visible from this side. Patchcords or cable sets will exit this side of the receiver.
3. Rotate the receiver until the smooth face of the frame is visible (**Figure B**). Note the mounting screw hole exits on this side. This is the mating face of the receiver when an iCon module is installed.
4. The D1 receiver is equipped with guide bushings (**Figure B**). These bushings accept the guide pins of the ITA frame.

NOTE: The top/first position of the module should be opposite of the side of the D1 part number marking when looking at the mating face.

NOTE: The standard D1 receiver is *not* equipped with floating bushings in each corner. Floating bushings are only available on the ITA.

NOTE: More information on module installation is provided on page 5.

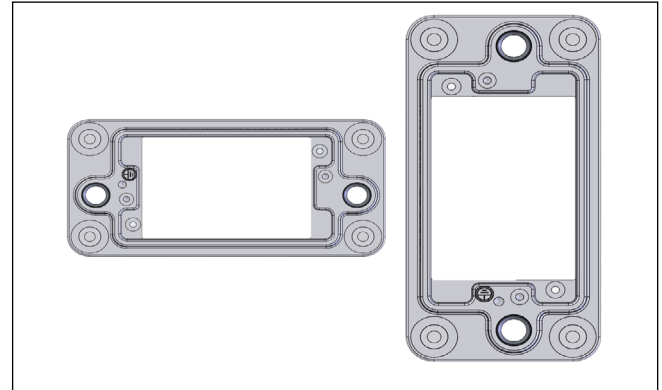

Figure A. Module installation side, indicated by the in-set face for the module.

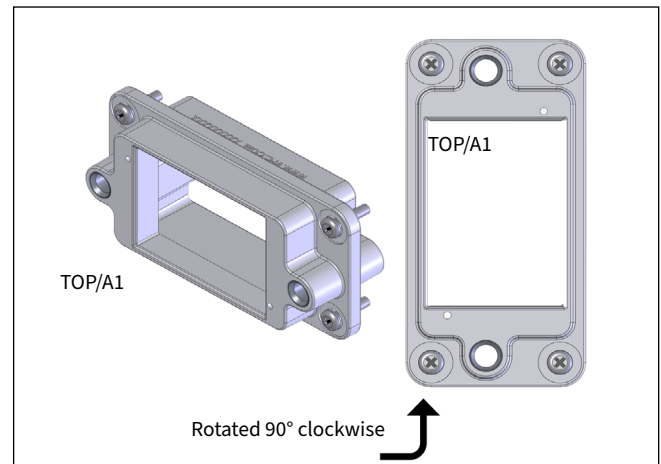

Figure B. Mating face, indicated by the smooth surface surrounding the module (Inverse of module installation side).

ITA PART IDENTIFICATION

PART # 410131102

IDENTIFICATION

1. Locate the frame with guide pins. This is the ITA frame.
2. Rotate the ITA until the smooth face of the frame is visible (**Figure A**). The guide pins should be visible from this view. This is the mating face of the ITA frame.
3. Rotate the ITA until the in-set face of the frame is visible. Note the mounting screw holes on the interior of the frame. This is the module installation face (**Figure B**). The iCon module will be installed on this side.

NOTE: The top/first position of the module should be opposite of the side of the D1 part number marking when looking at the mating face.

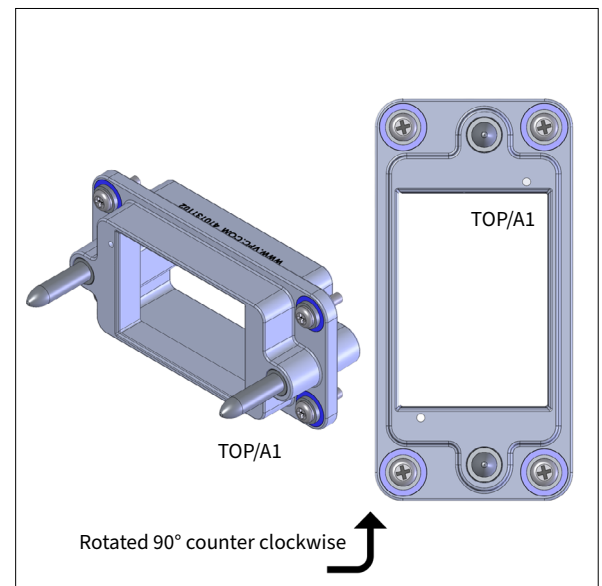

Figure A. Mating side of the ITA.

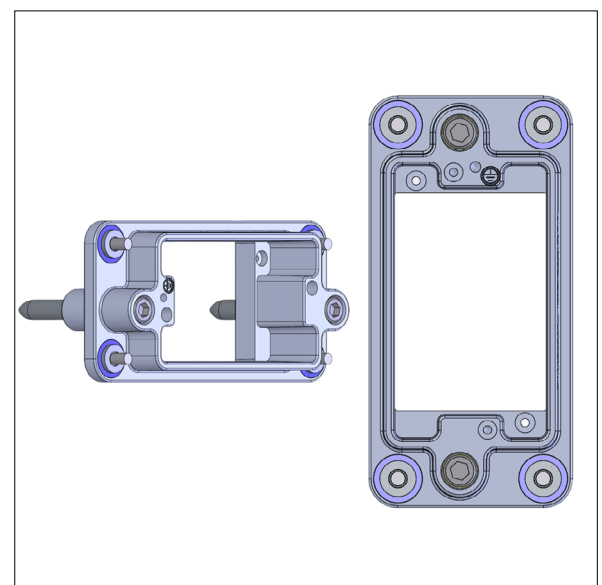

Figure B. Module installation side for the ITA. (Inverse of mating-side).

[RETURN TO INDEX](#)

RECEIVER AND ITA ENGAGEMENT

PART # 310131102, 410131102

INSTRUCTIONS

1. Align the ITA's guide pins with the receiver's guide bushings.
2. Push the ITA onto the receiver.
3. When configuring the engagement settings for your test interface, be sure to leave a small gap between the ITA and receiver frame when in the fully mated position. This gap will prevent continual contact of the frames upon mating, causing unnecessary friction and wear. VPC recommends a maximum gap distance of 0.025" [.635 mm].

NOTE: The guide bushings are positioned off-center to prevent engagement mismatch.

NOTE: For optimum performance and system longevity, VPC recommends distributing the load evenly in all interfaces.

NOTE: To determine the maximum mating force for your configuration, VPC recommends contacting a VPC Field Application Engineer online at vpc.com.

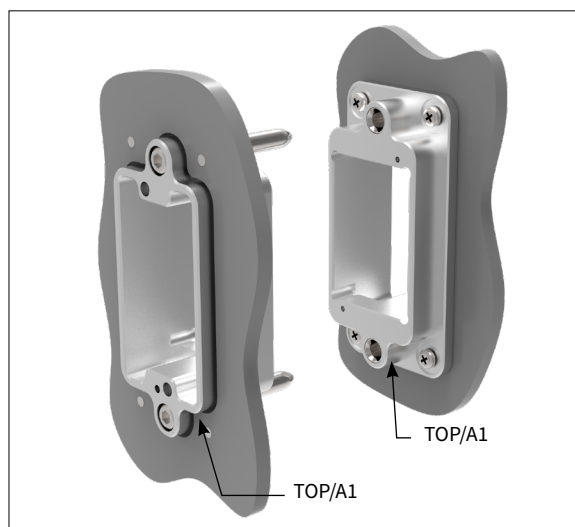

Figure A. The ITA and Receiver Disengaged



Figure B. The ITA and Receiver Engaged

RECEIVER PANEL MOUNTING

PART # 310131102

TOOLS REQUIRED

Phillips Head Screwdriver

INSTRUCTIONS

1. Prepare the mounting surface using the dimensions provided (**Figure A**).
2. Attach the D1 receiver to the panel with the provided M3 Phillips head screws.
3. Torque the screws to 6.5 in-lbs [0.73 Nm].
4. The D1 receiver frame is designed to be used in a modular configuration. As long as the minimum distances between frames are observed, multiple receiver frames can be engaged simultaneously as a single test interface. These frames can be placed adjacent to one another in horizontal or vertical configurations.

Figure A. Recommended panel cutout.

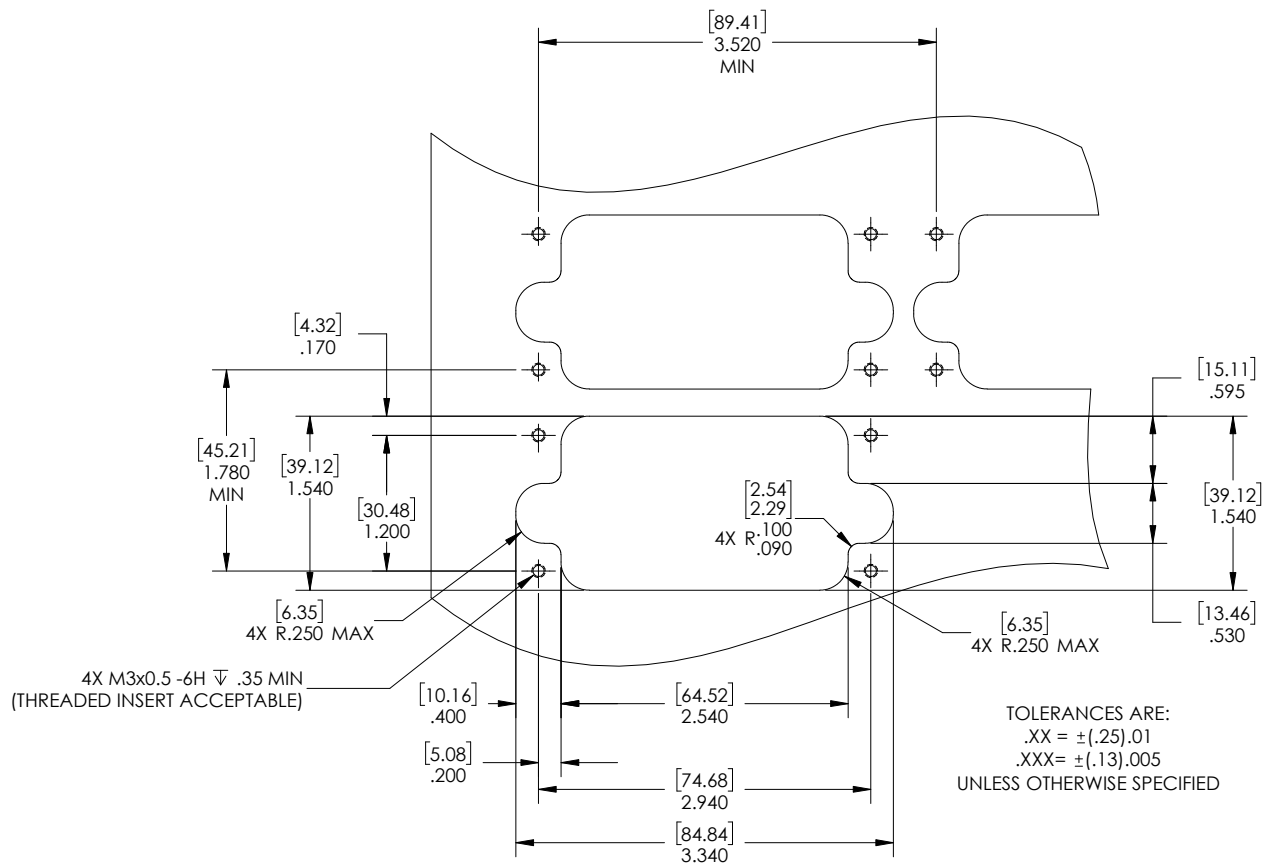
[RETURN TO INDEX](#)

MODULE INSTALLATION AND REMOVAL

PART # 310131102, 410131102

The D1 receiver is designed to allow module mounting from the rear of the frame. This permits the user to easily mount wired cable assemblies without having to route them through the receiver frame.

TOOLS REQUIRED

Phillips Head Screwdriver

NOTE: The receiver strain relief plate or the ITA cover may need to be removed prior to installing or removing an i1 module. Refer to page 6 for instructions on how to perform these steps.

NOTE: If the application requires, receiver modules may be installed in the ITA and ITA modules in the receiver. Beware this is a non-standard practice and not often done. However, if this is done you must ensure the correct contacts remain with the correct module. For example, receiver contacts in a receiver module and vice versa.



WHEN USING THE D1 IN THIS CONFIGURATION, THE ALIGNMENT PINS CAN DAMAGE THE ITA CONTACTS IF THE ITA IS NOT PROPERLY ALIGNED WITH THE RECEIVER. USE CAUTION WHEN ENGAGING THE ITA TO AVOID DAMAGING PINS.

INSTALLATION

1. Place the module in the receiver or ITA frame until the upper and lower module screws touch the mating holes in the inner frame. Install the module so that position 1 is located at the top of the receiver/ITA frame.
2. Using a Phillips head screwdriver, tighten the top screw 1 to 2 full revolutions while pushing lightly against the face of the module.
3. Maintain this pressure while tightening the bottom screw 1 to 2 full revolutions.
4. Repeat this sequence until the module is seated. Torque both screws 1.5 in-lbs [0.16 Nm].

MODULE REMOVAL

1. Loosen the top screw 1 to 2 full revolutions then loosen the bottom screw 1 to 2 full revolutions.
2. Repeat this sequence until the module is separated from the receiver or ITA.

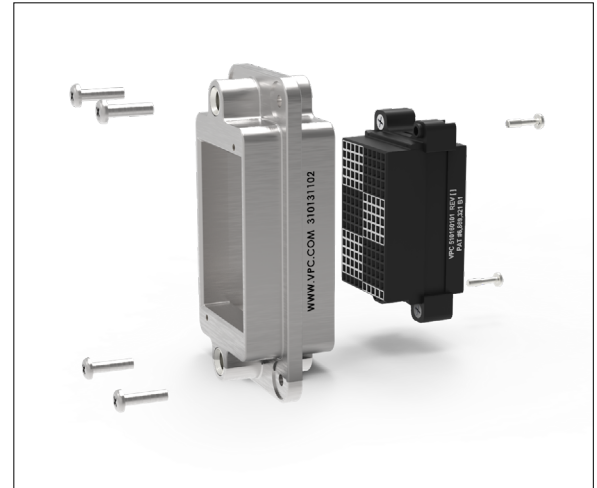

Figure A. D1 receiver and iCon series receiver module.

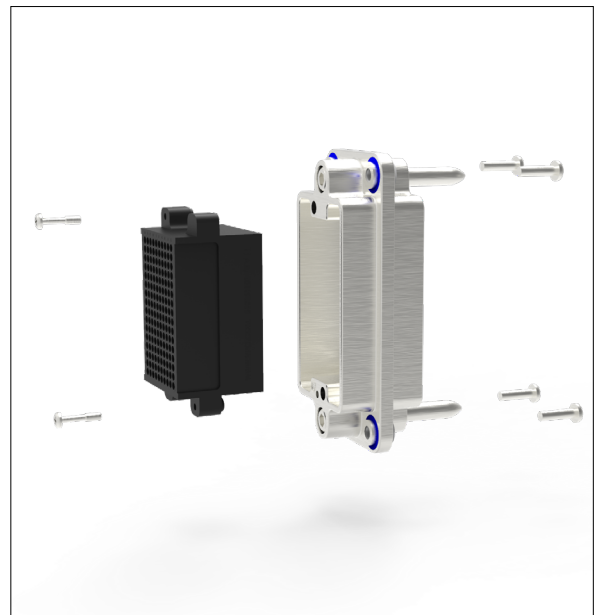

Figure B. D1 ITA and iCon series ITA module.

[RETURN TO INDEX](#)

STRAIN RELIEF ASSEMBLY

PART # 310131102, 410131102, 310113531, 310113582

TOOLS REQUIRED

Phillips Head Screwdriver

ASSEMBLY

1. Using the Phillips head screwdriver, fasten the strain relief to the back (wiring) side of the D1 receiver or ITA with the 2-56 screws and nuts provided (**Figure A**). Place the nuts in the keying positions from the front side of the frame.
2. Torque screws to 2 in-lbs [0.23 Nm].
3. Use the zip ties included with the strain relief to restrain the wires.

NOTE: If using 8 AWG or 10 AWG wire, the iCon Stand Off Strain Relief Kit, Part # 310113582, will be required. Install patchcords into module before attaching strain relief.

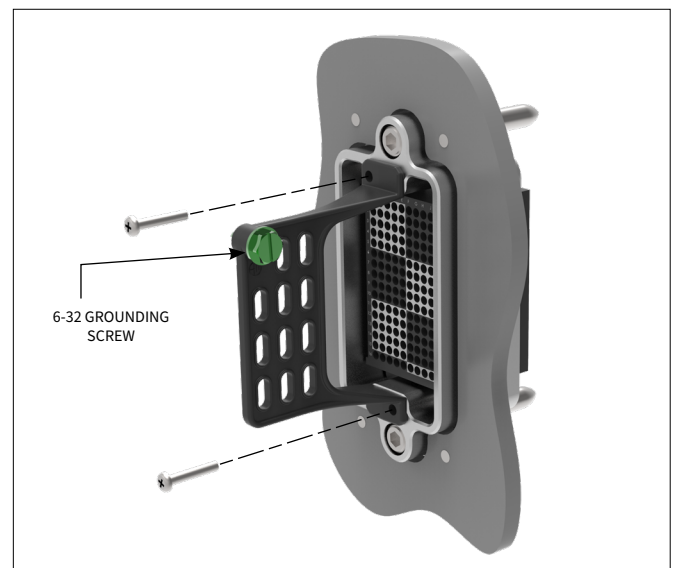

Figure A. D1 receiver with strain relief.