



D3/D4 USER MANUAL

INDEX ([CLICK TO NAVIGATE TO PAGE](#))

PAGE

- 1 [RECEIVER PART IDENTIFICATION](#)
- 2 [ITA PART IDENTIFICATION](#)
- 3 [RECEIVER AND ITA ENGAGEMENT](#)
- 4 [RECEIVER MOUNTING](#)
- 5 [90 SERIES MODULE INSTALLATION AND REMOVAL](#)
- 6 [ICON SERIES MODULE INSTALLATION AND REMOVAL](#)
- 7 [90 SERIES MODULE STRAIN RELIEF ASSEMBLY](#)
- 8 [ICON SERIES MODULE STRAIN RELIEF ASSEMBLY](#)
- 9 [REVERSE MODULE FUNCTIONALITY](#)

*Please note that any printed or downloaded User Manual may not reflect the most current revisions.
The information contained herein is subject to change.
For the most current information available, visit vpc.com.*

RECEIVER PART IDENTIFICATION

PART # 310131101

NOTE: The D3/D4 receiver can be configured with (3) 90 Series modules or (4) iCon modules, depending on the application.

PARTS OF THE RECEIVER

1. Identifying the top of the receiver frame is important when installing modules. Optimum performance and mating life is achieved when pin location 1 of the module is installed on top. Regardless of the frame's orientation, vertical or horizontal, the top is always the side that has module installation concentric screw holes inset in the frame. The bottom side has horseshoe shaped holes (**Figure D**).
2. The module installation side of the frame is the grooved face of the frame (**Figure A**). The mounting screw holes are on the top, bottom, and sides of the receiver.
3. Both 90 Series modules and iCon Series modules are installed from this side. The grooved side is also the mating face of the receiver frame when 90 Series modules are installed. Patchcords or wiring, will exit on the opposite side.
4. The mating face of the receiver is the smooth side of the frame (**Figure B**). Note the mounting screw hole exits on this side. This is the mating face of the receiver when iCon modules are installed. Patchcords, or wiring, will exit on the opposite side.

NOTE: More information on module installation is provided on pages 5 & 6.

5. The D3/D4 receiver is equipped with guide bushings (**Figure C**). These bushings accept the guide pins of the ITA frame. Note that the guide bushings are offset to provide polarization of the frames when mating.
6. In each corner, the receiver frame is equipped with a stainless bushing. These bushings are designed to move, or “float,” with a radius of 0.020" [0.51 mm]. This movement account for any float movement when the two frames are being engaged.

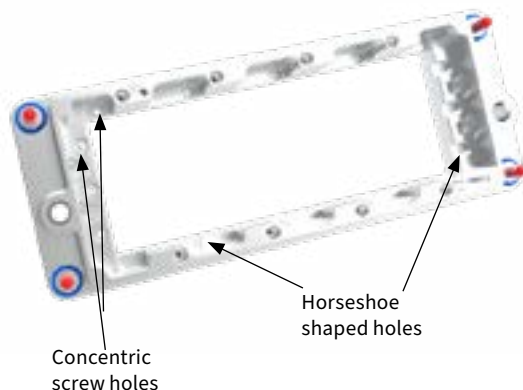

Figure D.



Figure A. Grooved face of the receiver frame. Mating face for 90 Series modules.



Figure B. Smooth face of the receiver frame. Mating face for iCon Series modules.

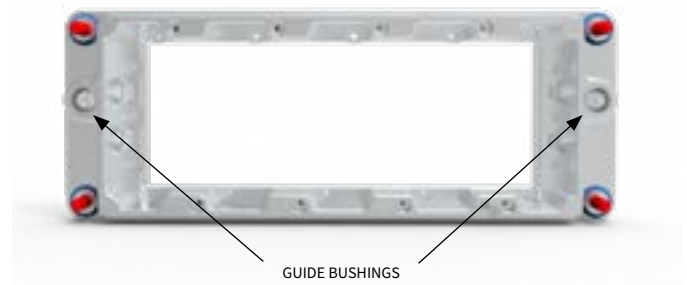

Figure C. The receiver bushings are slightly offset to prevent mismatched engagement with ITA frame.

[RETURN TO INDEX](#)

ITA PART IDENTIFICATION

PART # 410131101

PARTS OF THE ITA

1. Identifying the top of the ITA frame is important when installing modules. Optimum performance and mating life is achieved when pin location 1 of the module is installed on top. Regardless of the frames orientation, vertical or horizontal, the top is always the side that has concentric screw holes inset in the frame for use to install modules. The bottom side has horseshoe shaped holes (**Figure C**).
2. The module installation side of the ITA frame is the grooved face of the frame. Note the mounting screw holes on the top, bottom, and sides of the ITA(**Figure B**). Both 90 series modules and the iCon modules will be installed on this side.
3. To mating side of the ITA frame is the smooth side (**Figure A**). The guide pins are visible on this side, also. This is the mating face for both 90 Series modules and iCon modules.

NOTE: More information on module installation is provided on pages 5 & 6.

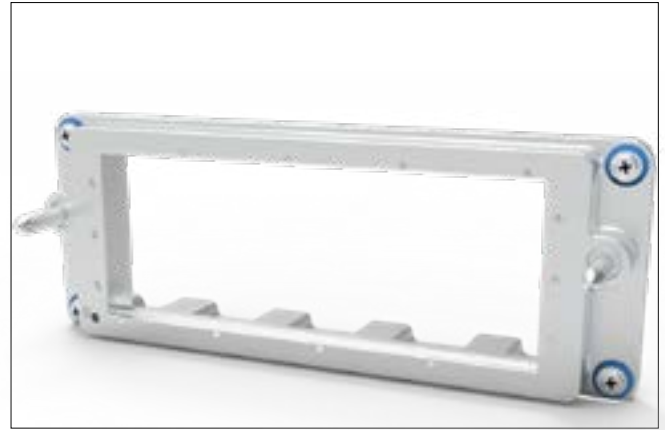

Figure A. Smooth face of the ITA frame



Figure B. Grooved face of the ITA frame.

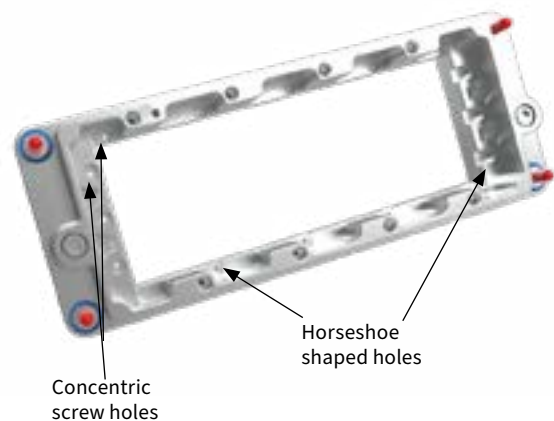

Figure C.

[RETURN TO INDEX](#)

RECEIVER AND ITA ENGAGEMENT

PART # 310131101, 410131101

PREPARING FRAMES FOR ENGAGEMENT

1. Align the ITA guide pins with the receiver's guide bushings.
2. Push the ITA onto the receiver.
3. When configuring the engagement settings for a test interface, it is good practice to leave a small gap between the ITA and receiver frame when in the fully mated position. This gap will prevent the frames from making contact during each mating cycle, thus reducing unnecessary wear and friction. VPC recommends a maximum gap distance of 0.025" [.635 mm].

NOTE: The guide bushings are offset to provide polarization of the frames to prevent engagement mismatch.

NOTE: For optimum performance and system longevity, distributing the load evenly in all interfaces.

NOTE: To determine the maximum mating force for your configuration, VPC recommends contacting a VPC Field Application Engineer. To contact a Field Application Engineer, please [click here](#).



Figure A. The ITA and Receiver Disengaged



Figure B. The ITA and Receiver Fully Engaged

RECEIVER MOUNTING

PART # 310131101

TOOLS REQUIRED

Phillips Head Screwdriver

MOUNTING

1. Prepare the mounting surface using the dimensions provided in **Figure A**.
2. Attach the D3/D4 receiver to the panel with the provided M3 Phillips head screws.
3. Torque the screws to 2 in-lbs [0.23 Nm].
4. The D3/D4 receiver frame is designed to be used in a modular configuration. As long as the minimum distances between frames are observed, multiple receiver frames can be engaged simultaneously as a single test interface. These frames can be placed adjacent to one another in horizontal or vertical configurations.

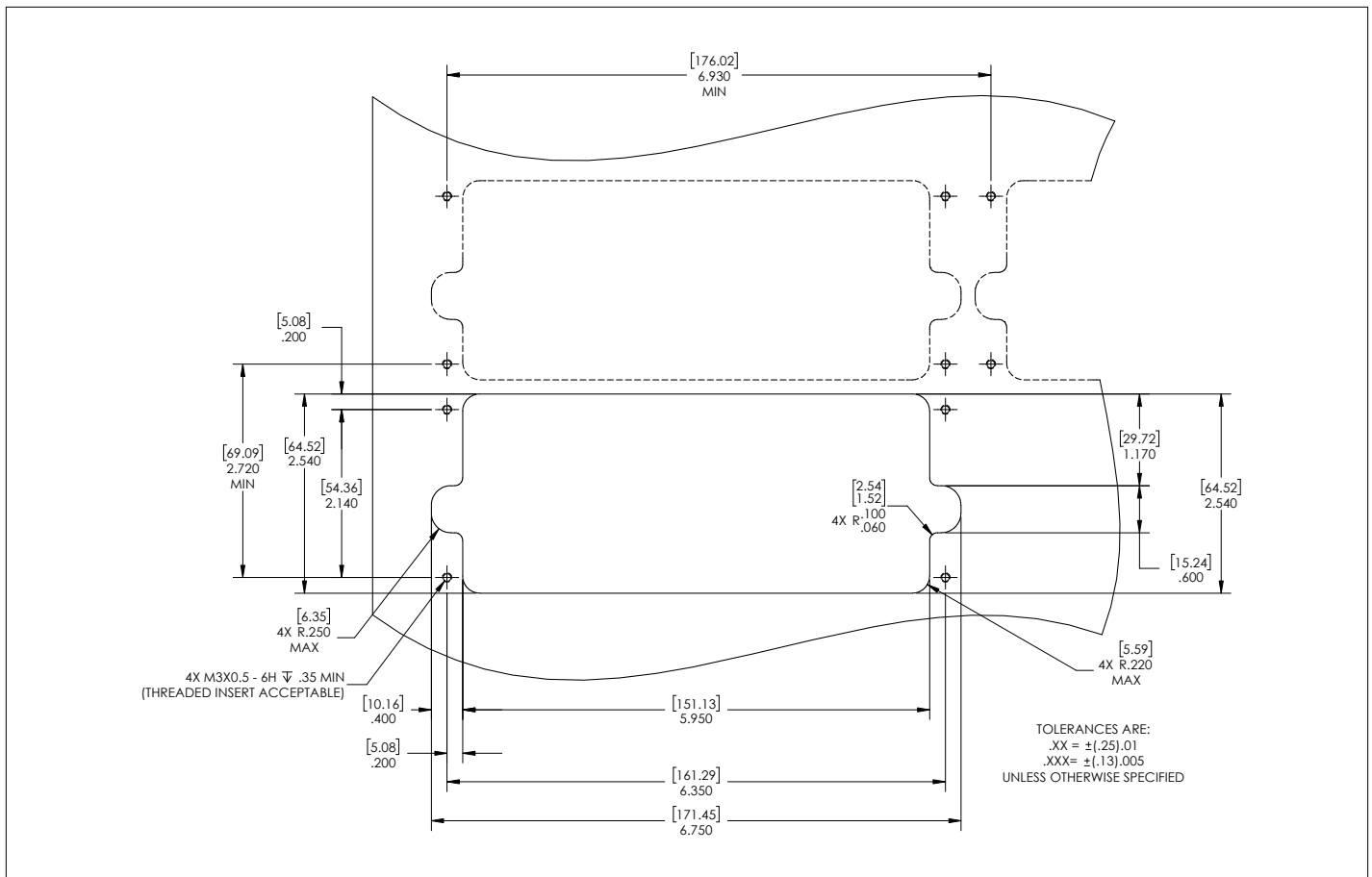

Figure A. Recommended panel cutout.

[RETURN TO INDEX](#)

90 SERIES MODULE INSTALLATION AND REMOVAL

PART # 310131101, 410131101

TOOLS REQUIRED

3/32" Allen wrench or balldriver

ITA AND RECEIVER MODULE INSTALLATION

NOTE For information on locating the top and bottom of the ITA and receiver frame and which side is the module installation side, reference pages 1 & 2.

1. Locate pin 1 of the module. Each module has a specific pin 1 indicator to ensure that the module is positioned correctly. For optimum performance and cycle life install pin 1 at the top of the frame.
2. Place the module in the receiver or ITA frame until the upper and lower module screws touch the mating holes in the inner frame.
3. Using a 3/32" Allen wrench or balldriver, tighten the top screw while pushing lightly against the face of the module until the screw is seated.
4. Maintain this pressure while tightening the bottom screw until the screw is seated.
5. Torque both screws 1.5 in-lbs. [0.16 Nm].

MODULE REMOVAL

1. To remove the module, simply reverse the installation process by loosening the screws.

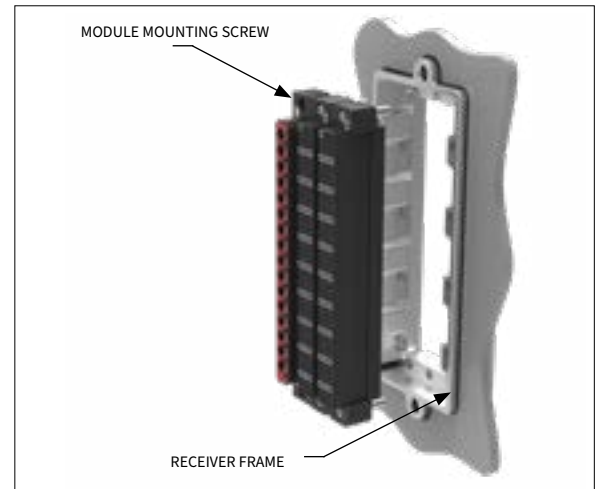

Figure A. D3/D4 receiver and 90 Series receiver module.

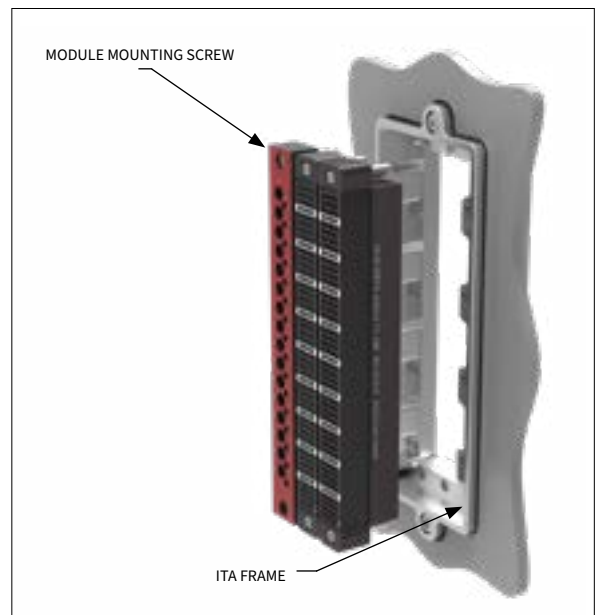

Figure B. D3/D4 ITA and 90 Series ITA module.

ICON SERIES MODULE INSTALLATION AND REMOVAL

PART # 310131101, 410131101

TOOLS REQUIRED

Phillips Head screwdriver

ITA AND RECEIVER MODULE INSTALLATION

NOTE For information on locating the top and bottom of the ITA and receiver frame and which side is the module installation side, reference pages 1 & 2.

1. Locate pin 1 of the module. Each module has a specific pin 1 indicator to ensure that the module is positioned correctly. For optimum performance and cycle life install pin 1 at the top of the frame.
2. Using a Phillips Head screwdriver, tighten the top screw while pushing lightly against the face of the module until the screw is seated.
3. Maintain this pressure while tightening the bottom screw until the screw is seated.
4. Torque both screws 1.5 in-lbs. [0.16 Nm].

MODULE REMOVAL

1. To remove the module, simply reverse the installation process by loosening the screws.

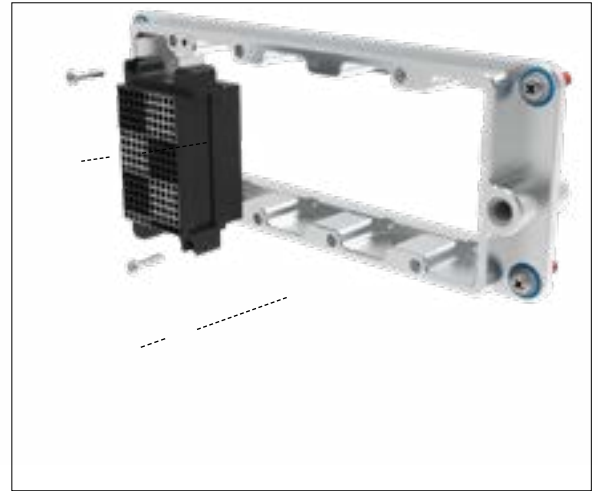

Figure A. D3/D4 receiver and iCon receiver module.



Figure B. D3/D4 ITA and iCon ITA module.

90 SERIES RECEIVER MODULE STRAIN RELIEF ASSEMBLY

PART # 510150115, 510109349

Strain relief plates are designed to absorb the majority of the force put on module cables and wiring in an interface configuration. Relieving the strain on wiring helps to keep terminations intact and reduce wire wear. Each strain relief plate allows for a variety of wire spacing options. Zip ties are used to secure wires to the strain relief plate snugly, but without force. For more information on strain relief, consult VPC's Strain Relief User Manual, available on vpc.com.

TOOLS REQUIRED

Phillips Head Screwdriver

ASSEMBLY

1. Observe the groove indentations on each side of the module. (**Figure A**). This grooved indentation is where the strain relief and the module will interlock.
2. Separately, slide each half of the strain relief plate into the grooved indentations. Using a Phillips head screwdriver, fasten the provided 4-40 screws into place (**Figure B**) to assemble the strain relief plate.
3. Torque screws to 2 in-lbs [0.23 Nm].
4. The module can now be mounted to the receiver as one assembly.



THE INSTRUCTIONS ABOVE ARE INTENDED ONLY FOR THE PART #'S PROVIDED. BE SURE TO REVIEW THE INSTRUCTIONS IN THE PRODUCT DRAWING OR STRAIN RELIEF USER MANUAL FOR YOUR STRAIN RELIEF PLATE, AS STRAIN RELIEF INSTRUCTIONS MAY VARY BY MODULE.

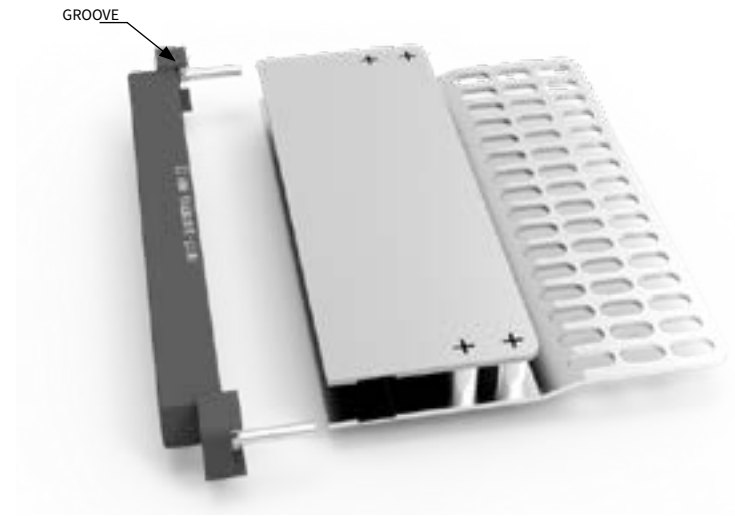

Figure A. View of grooved indentations on part #510150115.

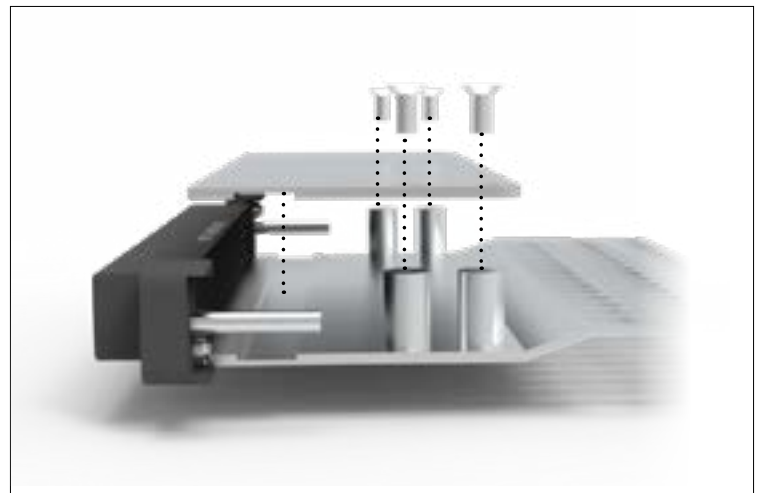

Figure B. Fitting of strain relief plate to module part #510150115.

ICON RECEIVER MODULE STRAIN RELIEF ASSEMBLY

PART # 310131101, 310113531, 310113582

TOOLS REQUIRED

Phillips Head Screwdriver

ASSEMBLY

1. Using a Phillips head screwdriver, fasten the strain relief to the back (wiring) side of the D3/D4 receiver with the two 2-56 screws provided (**Figure A**). All strain relief plates for iCon Series modules fasten directly to the receiver instead of the module.
2. Torque screws to 2 in-lbs [0.23 Nm].
3. Use the zip ties included with the strain relief plate to attach wiring to the plate.

NOTE: Two 2-56 nuts are included with the strain relief plate; however, they are not required for this application. The screws will enter the tapped mounting screw holes instead.

NOTE: If using 8 AWG or 10 AWG wire, the iCon Strain Relief Stand-Off Kit, p/n 310113582, will be required. Install patchcords into module before attaching strain relief.

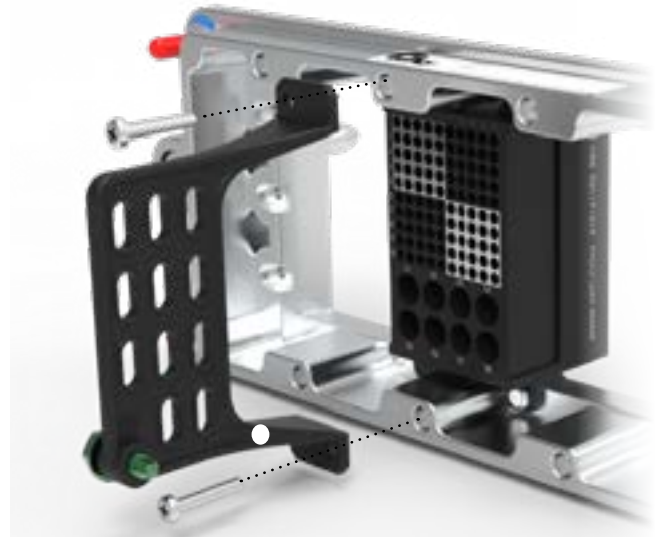

Figure A.

REVERSE MODULE FUNCTIONALITY

PART # 410131101

TOOLS REQUIRED

9/64" Allen wrench or balldriver

NOTE: In some specific applications or system builds, using VPC modules in reverse functionality can be helpful. Reverse functionality is defined as using ITA modules in a receiver frame and vice versa. This page provides instructions for swapping the guide pins on the ITA frame of the D3/D4. This adjustment is necessary if using the iDock D3/D4 with reverse functionality and 90 Series modules only. If using the D3/D4 with reverse functionality with iSeries modules, this adjustment is not needed.

INSTRUCTIONS

1. Locate the guide pin screws on the D3/D4 ITA frame (**Figure A**) and use a 9/64" Allen wrench or balldriver to loosen the guide pin screws.
2. Remove the guide pins, screws, and washers from the ITA (**Figure B**) and flip direction of hardware. The guide pin screws should now be facing the same direction as the mounting screws (**Figure C**). Make sure the guide pins are fully seated to properly reattach them to the frame.
3. Tighten the guide pin screws while pushing lightly against the face of the frame until the screws are seated.
4. Torque both screws to 1.5 in-lbs [0.16 Nm].
6. Now the ITA frame is ready to be loaded with the 90 Series receiver modules for your application. Follow the instructions on page 5 of this manual for module installation.

NOTE: Be sure to use the correct contacts in the corresponding modules. For example, ITA contacts in ITA modules.

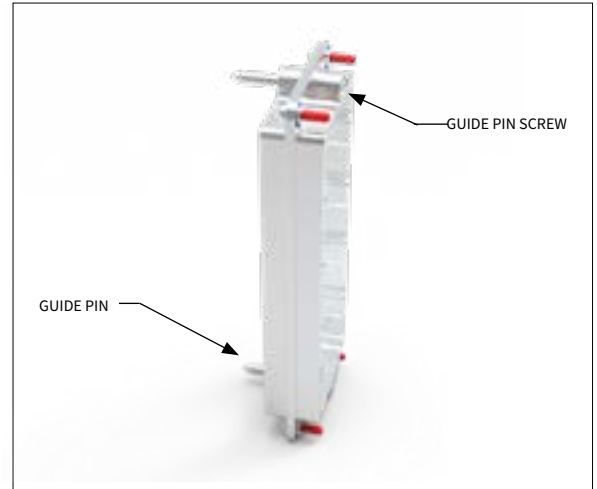

Figure A. D3/D4 ITA.

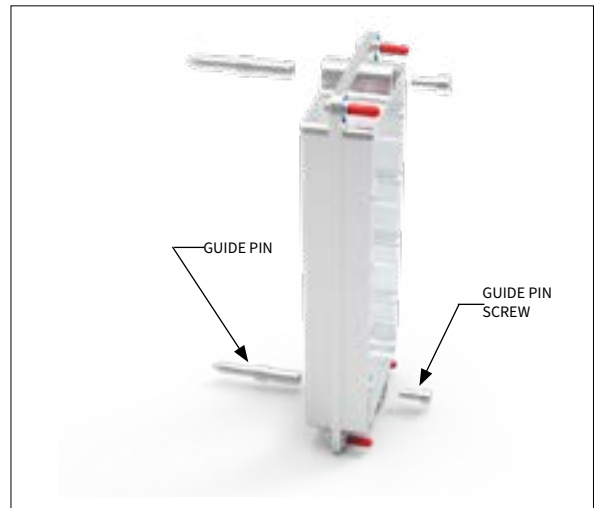

Figure B. D3/D4 ITA with guide pins and guide pin screws removed.

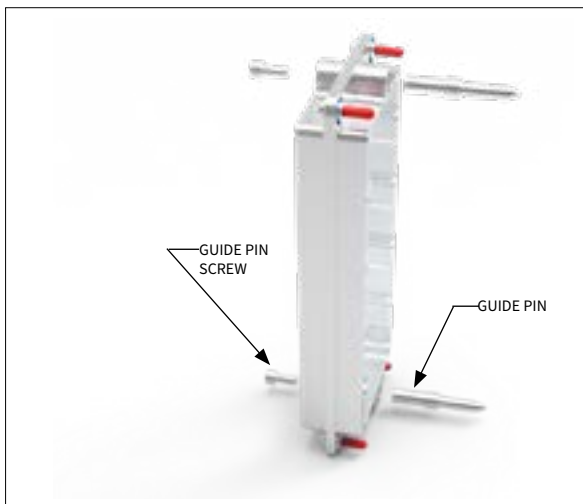

Figure C. D3/D4 ITA with guide pins and guide pin screws flipped, removed and ready to insert and tighten.

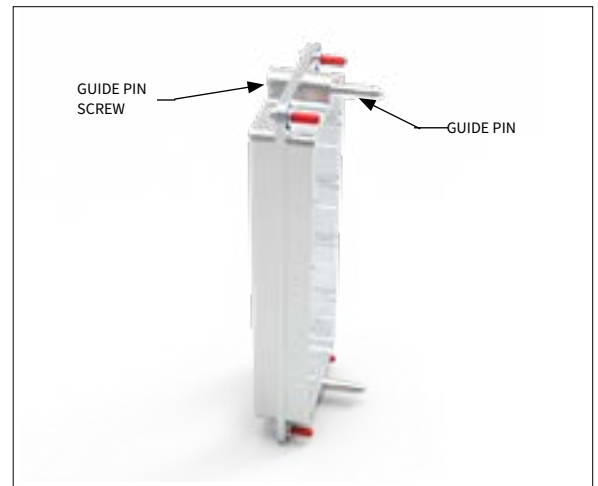

Figure D. D3/D4 ITA with reversed guide pins.

[RETURN TO INDEX](#)