



G2, G6(X) & G10(X) USER MANUAL

**PLEASE NOTE:* Although the specific part number for your model of G2, G6/G6x or G10/G10x ITA or receiver may not be referenced on an instruction page in this manual, many of the instructions are universally applicable across most models. If you have further questions, please consult that part number's drawing via its part page on our website, or [contact us](#).

INDEX ([CLICK TO NAVIGATE TO PAGE](#))

PAGE

- 2 [LOCATING RECEIVER/ITA MODULE POSITION 1](#)
- 3 [REMOVING ITA BACKSHELL](#)
- 4 [ENGAGING ITA WITH RECEIVER](#)
- 5 [KEYING PIN KIT USAGE](#)
- 6 [CABLE BUNDLE WIRE INFORMATION](#)
- 7 [VERTICAL HINGED MOUNTING FRAMES](#)
- 8 [G2 RECEIVER PANEL CUTOUT SPECIFICATIONS](#)
- 9 [G6 RECEIVER PANEL CUTOUT SPECIFICATIONS](#)
- 10 [G10 RECEIVER PANEL CUTOUT SPECIFICATIONS](#)
- 11 [G10X RECEIVER PANEL CUTOUT SPECIFICATIONS](#)
- 12 [SLIDE MOUNT NOTATION REGARDING U HEIGHT](#)
- 13 [PRECAUTIONARY NOTES/ TROUBLESHOOTING](#)
- 14 [MICROSWITCH REPLACEMENT](#)
- 15 [REMOVAL AND REPLACEMENT OF DOWEL/ALIGNMENT PINS](#)

*Please note that any printed or downloaded User Manual may not reflect the most current revisions.
The information contained herein is subject to change.
For the most current information available, visit vpc.com.*

LOCATING RECEIVER/ITA MODULE POSITION 1

G2 PART # RECEIVER 310120110, -112 / ITA 410120110,-112,-120

G6 PART # RECEIVER 310104318, -336, -344, -419/ ITA 410104273, -288, -331, -732

G10 PART # RECEIVER 310104317, -335 / ITA 410104123, -272, -375

Module position 1 in either the G2, G6 or G10, is located on the far left in the receiver. For proper mating, the mating module/ ITA position 1 should be loaded on the far right in the ITA.

To ensure proper mating of ITA and receiver, each model is equipped with keying pins labeled A-D (**Figures A and B**). For more information regarding keying pin usage refer to page 5 in this manual.

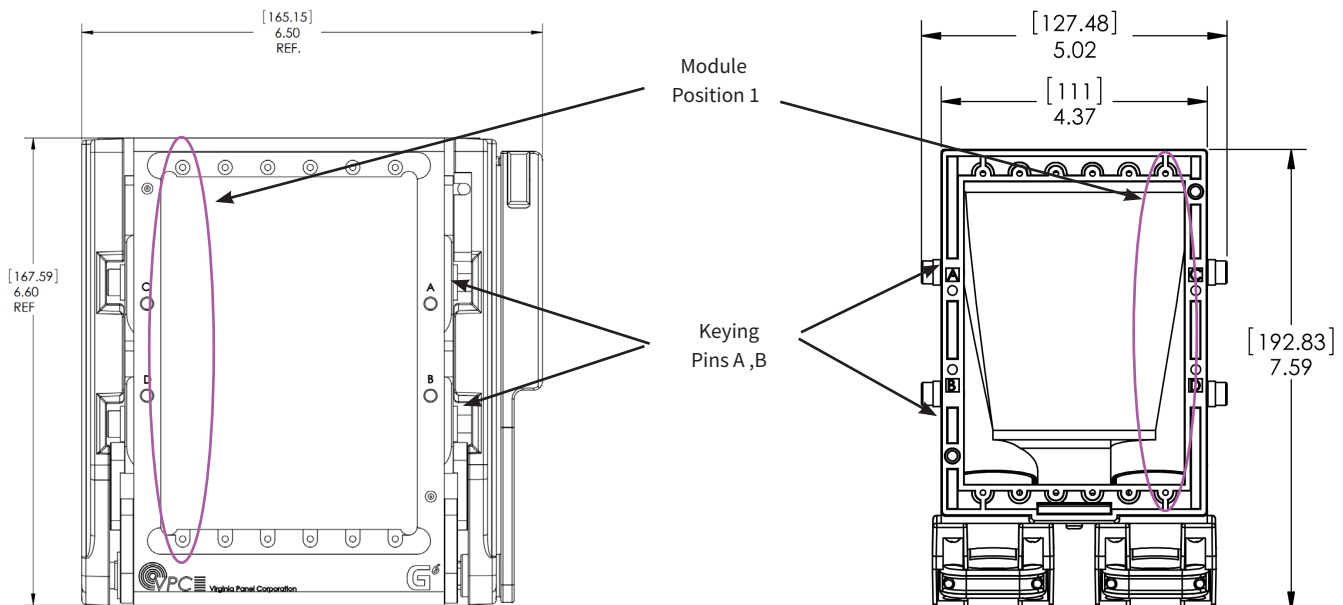

Figure A. G6 Receiver front/mating face

Figure B. G6 ITA front/mating ITA face

REMOVING ITA BACKSHELL

PART # 410120110, 410104273, 410104288, 410104272

Several G2, G6, and G10 ITAs are equipped with removable EMI-shielded backshells. The backshells slide up to provide access to wires and connectors. To slide the backshell up, be sure to first remove the screw(s) located at the base of the ITA. The G2 and G10 have two screws at the base, and the G6 has one. Once the backshell is put back into place, be sure to secure the screw(s) back in place, as the EMI shielding provided by the backshell will not take effect otherwise.

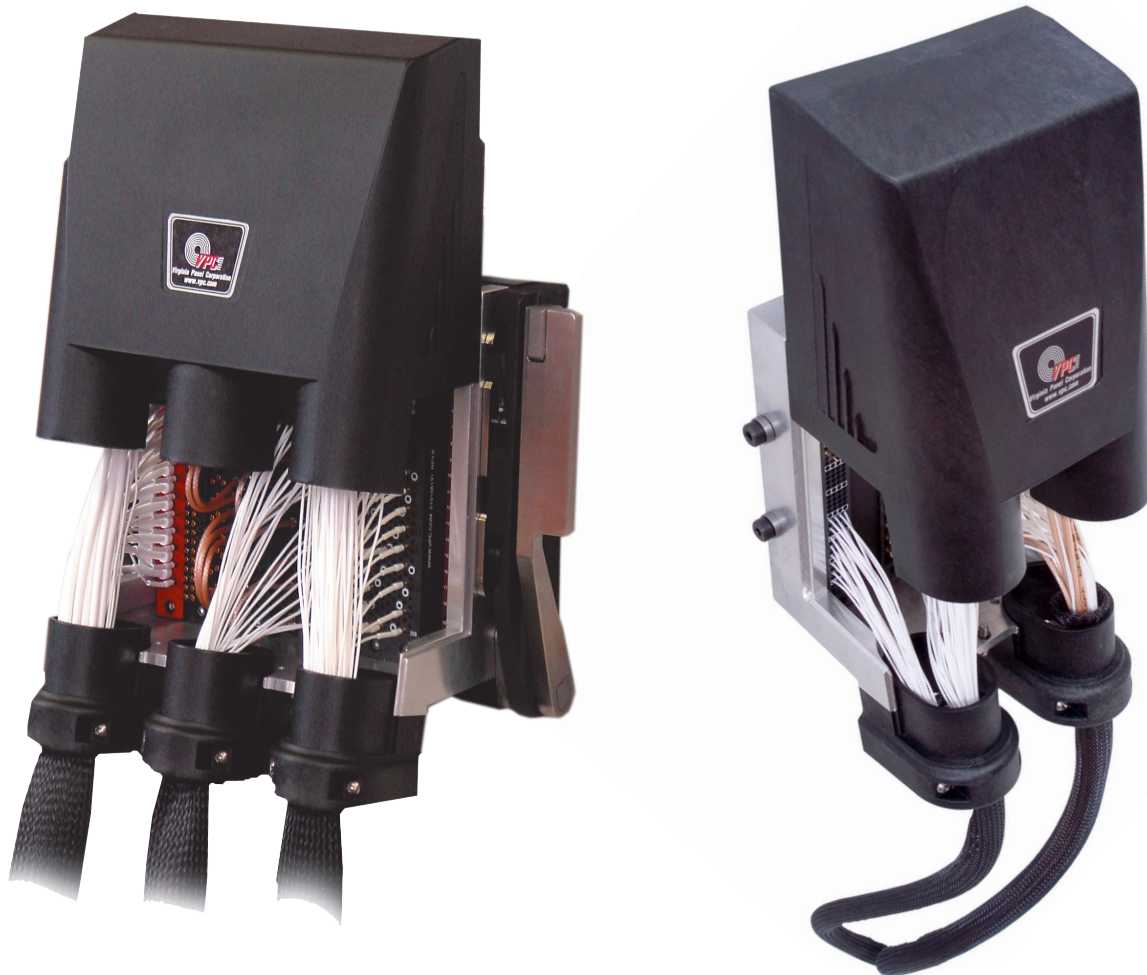

For drawings, specs and more information on the G2, G6 and G10 - please visit vpc.com.

[RETURN TO INDEX](#)

ENGAGING ITA WITH RECEIVER

RECEIVERS PART #s 310120110, 310120112, 310104317, 310104318, 310104335, 310104336

ITA PART#s 410104272, 410104273, 410104331, 410104375, 410120110, 410120112



WHEN ENGAGING ITA WITH RECEIVER, ENSURE THAT ITA IS PARALLEL WITH RECEIVER AND THAT ITA GUIDE PINS ARE ENGAGED AT THE SAME TIME. ALL POWER SUPPLIES FOR THE SYSTEM SHOULD BE DISCONNECTED PRIOR TO HANDLING. WHEN ENGAGING, BE SURE THAT ALL FOREIGN OBJECTS AND DEBRIS ARE CLEARED FROM THE SYSTEM.

1. Prior to engaging an ITA with the receiver for the first time, it is good practice to check that all modules (ITA and receiver) have been installed properly. This involves inspection of module ends to ensure even height relative to one-another. While checking this, the user should also verify the positioning of the modules. Pin 1 should always be at the top of both ITA and receiver modules. It is crucial for all modules to be installed properly. Improper installation will cause damage to modules, and possibly to the ITA and/or receiver. All ITA modules must match receiver module locations. Upon engagement, ITA modules will mate with their respective receiver modules.
2. With the ITA in the upright position and the receiver handle open, align guide pins with bushings on the ITA and mate.
3. The handle may now be moved to the upright/ closed position to engage contacts.
4. If there is any resistance when engaging, double-check module alignment and check for debris. If still experiencing difficulty engaging, contact VPC and speak to a VPC Engineer for assistance. Proceeding or using force may cause damage to the system that voids any warranty.



G10 ITA and Receiver

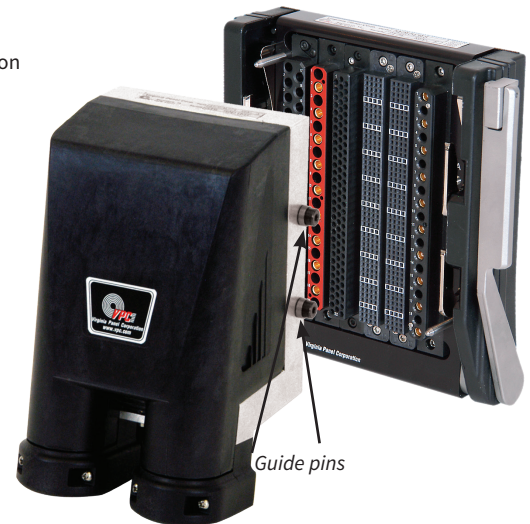

G6 ITA and Receiver

KEYING PIN KIT USAGE

PART # 310118112

The keying pin kit uses pins and screws that allow isolation of connectors to prevent operational mismatch. By design, pins are to be used in the receiver, and the screws are to be used in the ITA. If the pins are used in the ITA, other accessories such as protective covers will not function properly. Unless otherwise noted, VPC products that include the keying feature require purchase of the keying pin kit separately.

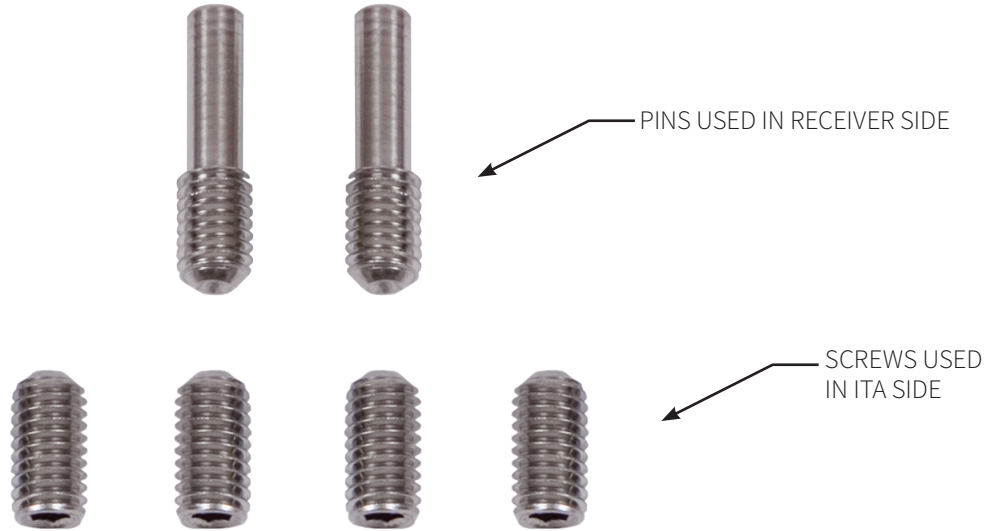

Use this table as a guide for keying pin locations.

PATTERN 1				PATTERN 4			
RECEIVER		ITA		RECEIVER		ITA	
PIN A INSTALLED	PIN C INSTALLED	SCREW A OPEN	SCREW C OPEN	PIN A OPEN	PIN C OPEN	SCREW A INSTALLED	SCREW C INSTALLED
PIN B OPEN	PIN D OPEN	SCREW B INSTALLED	SCREW D INSTALLED	PIN B INSTALLED	PIN D INSTALLED	SCREW B OPEN	SCREW D OPEN
PATTERN 2				PATTERN 5			
RECEIVER		ITA		RECEIVER		ITA	
PIN A INSTALLED	PIN C OPEN	SCREW A OPEN	SCREW C INSTALLED	PIN A OPEN	PIN C INSTALLED	SCREW A INSTALLED	SCREW C OPEN
PIN B INSTALLED	PIN D OPEN	SCREW B OPEN	SCREW D INSTALLED	PIN B INSTALLED	PIN D OPEN	SCREW B OPEN	SCREW D INSTALLED
PATTERN 3				PATTERN 6			
RECEIVER		ITA		RECEIVER		ITA	
PIN A OPEN	PIN C INSTALLED	SCREW A INSTALLED	SCREW C OPEN	PIN A INSTALLED	PIN C OPEN	SCREW A OPEN	SCREW C INSTALLED
PIN B OPEN	PIN D INSTALLED	SCREW B INSTALLED	SCREW D OPEN	PIN B OPEN	PIN D INSTALLED	SCREW B INSTALLED	SCREW D OPEN

Additional details can be found by accessing the drawing for this part number online at vpc.com.

[RETURN TO INDEX](#)

CABLE BUNDLE WIRE INFORMATION

PART# 410120110, 410104273, 410104272

Max Oblong Cable Opening Diameter= 1.59"

Formula

1. The formula below can be used to calculate the maximum number of wires recommended for a cable bundle used with a max cable exit of 1.59".

2. The table below shows a sampling of the maximum number of wires that will fit in: the single cable exit on the G2; each of the two oblong cable exits on the G6; or three oblong cable exits on the G10. For example, each exit will hold a maximum of 683 signal (20 AWG) wires **OR** 202 coax (RG316) wires.

$N = \left\{ \frac{D}{d} - 1 \right\}^2 (.907)$		
N=Number of Wires	D=Diameter of Converted Oblong Bushing	d=Outside Diameter of Wire

Calculations

Wire Type	Outside Diameter of Wire (d)	Number of Wires (N)
20 AWG Signal - Teflon	.056	683
10 AWG Power - PVC	.160	72
RG316 Coax - 50 OHM	.100	202

NOTE: Addition of shrink tubing or braid will reduce maximum number of wires through cable exit.

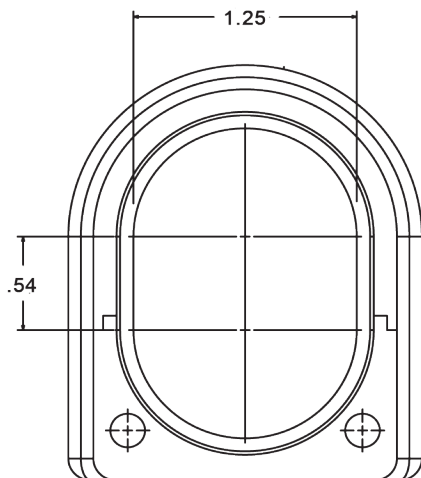

G2, G6 & G10 VERTICAL HINGED MOUNTING FRAME (VHMF)

PART # 310113391, 310113341, 310113342

*Note: a VHMF is not available for the G6x or G10x

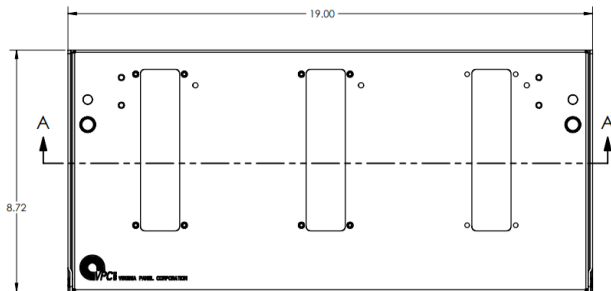

G2 • PART # 310113391

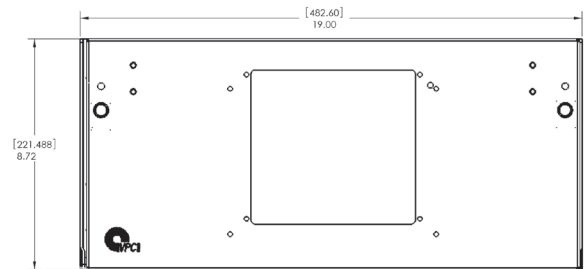

G10 • PART # 310113342

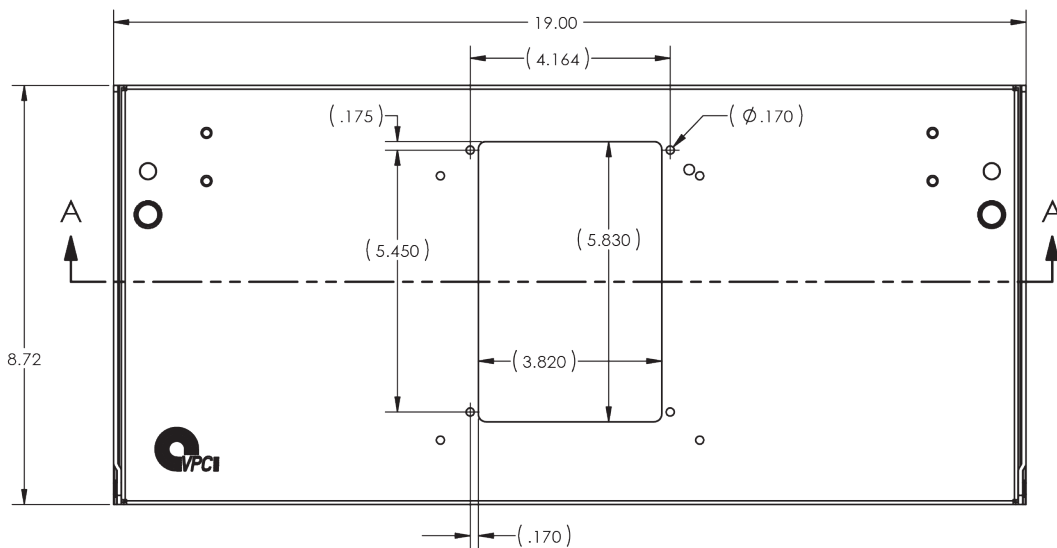

G6 • PART # 310113341

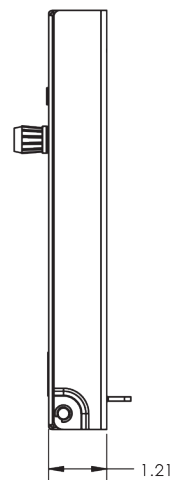

RECEIVER MOUNTING CUTOUTS

G2 PART #'S 310120110, 310120112

*For the most up-to-date and detailed information consult the product drawing available at vpc.com

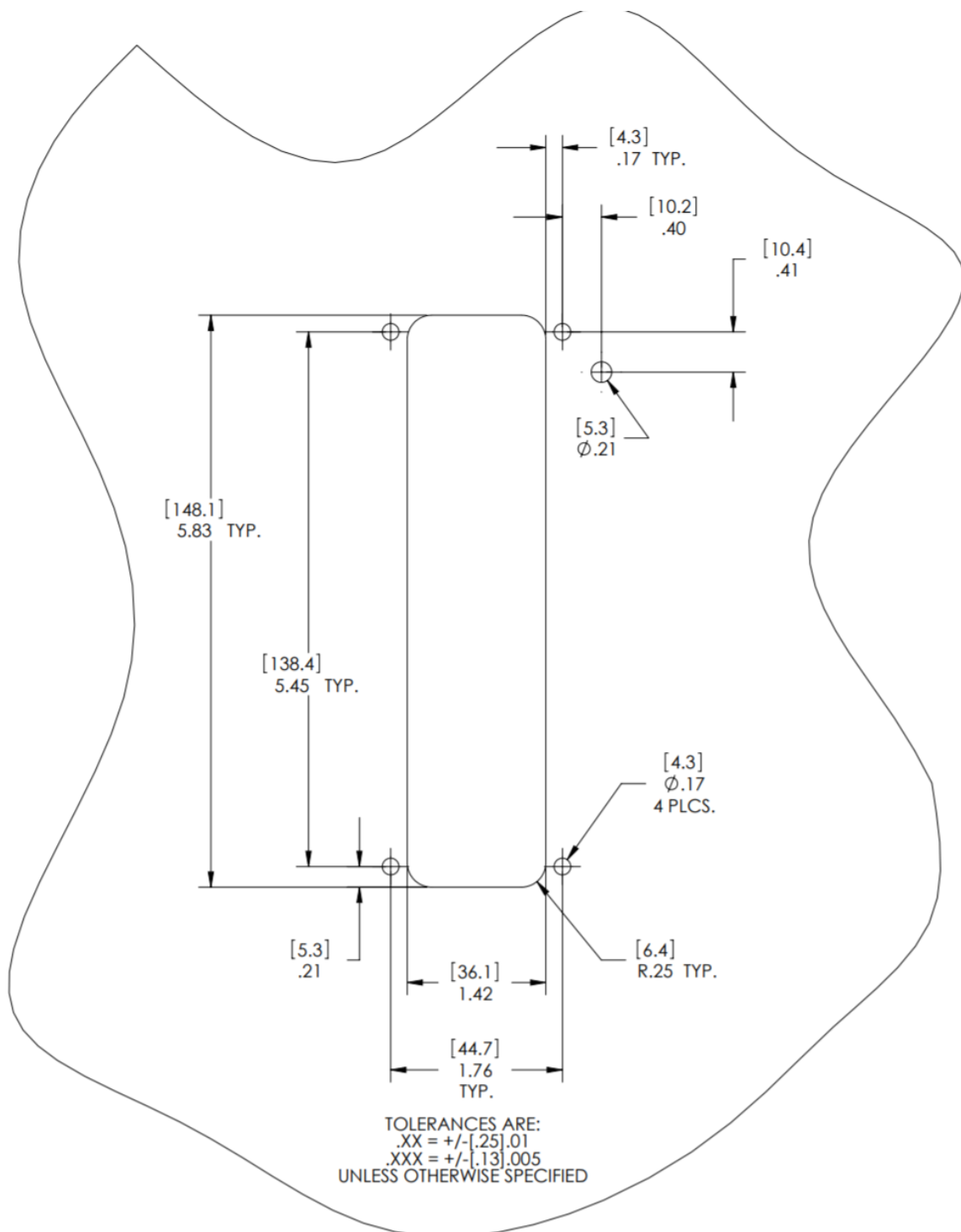
[RETURN TO INDEX](#)

RECEIVER MOUNTING CUTOUTS

G6 PART #'S 310104318, 310104336

*For the most up-to-date and detailed information consult the product drawing available at vpc.com

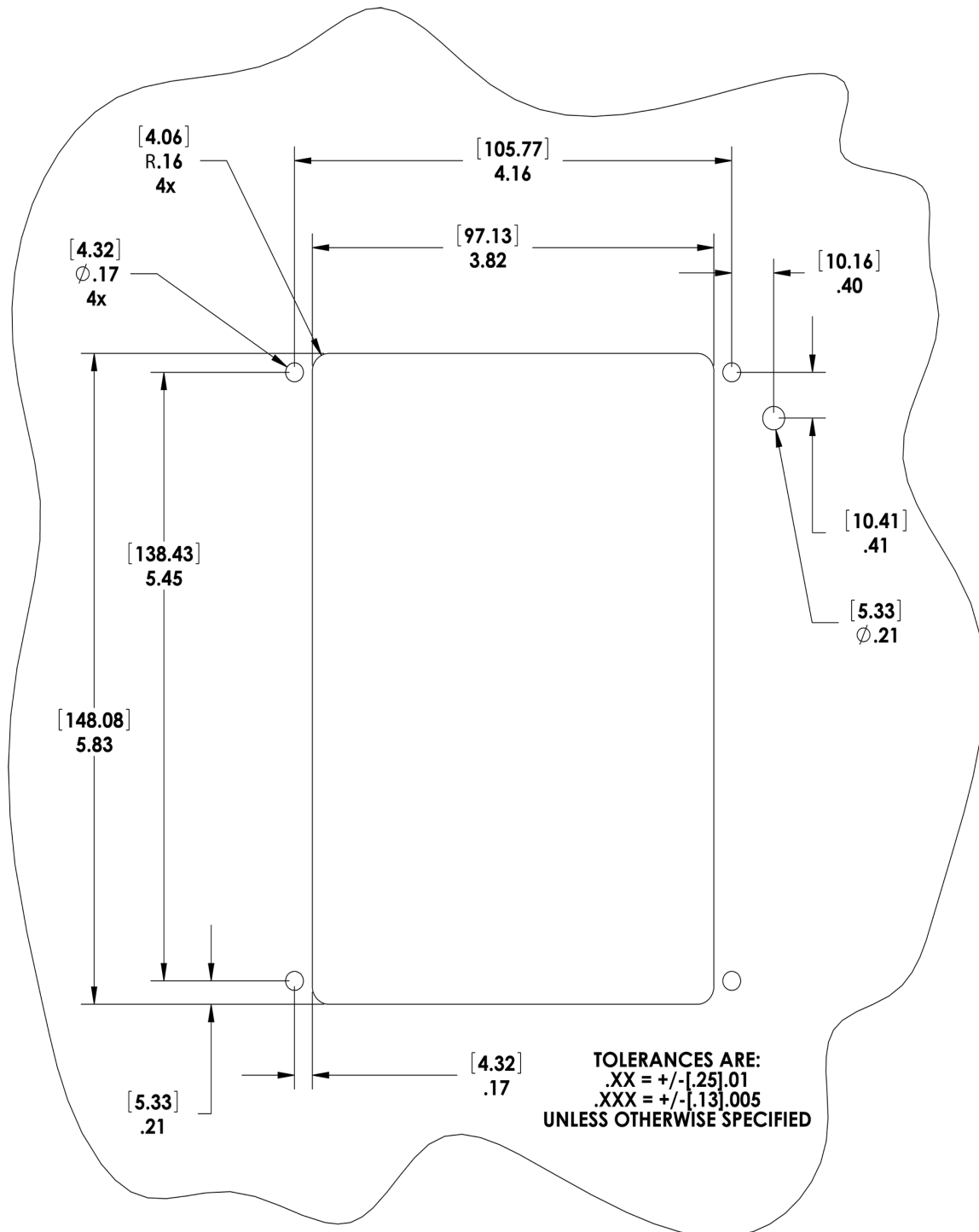
[RETURN TO INDEX](#)

RECEIVER PANEL CUTOUT

G10 PART #'S 310104317, 310104335

**For the most up-to-date and detailed information consult the product drawing available at vpc.com*

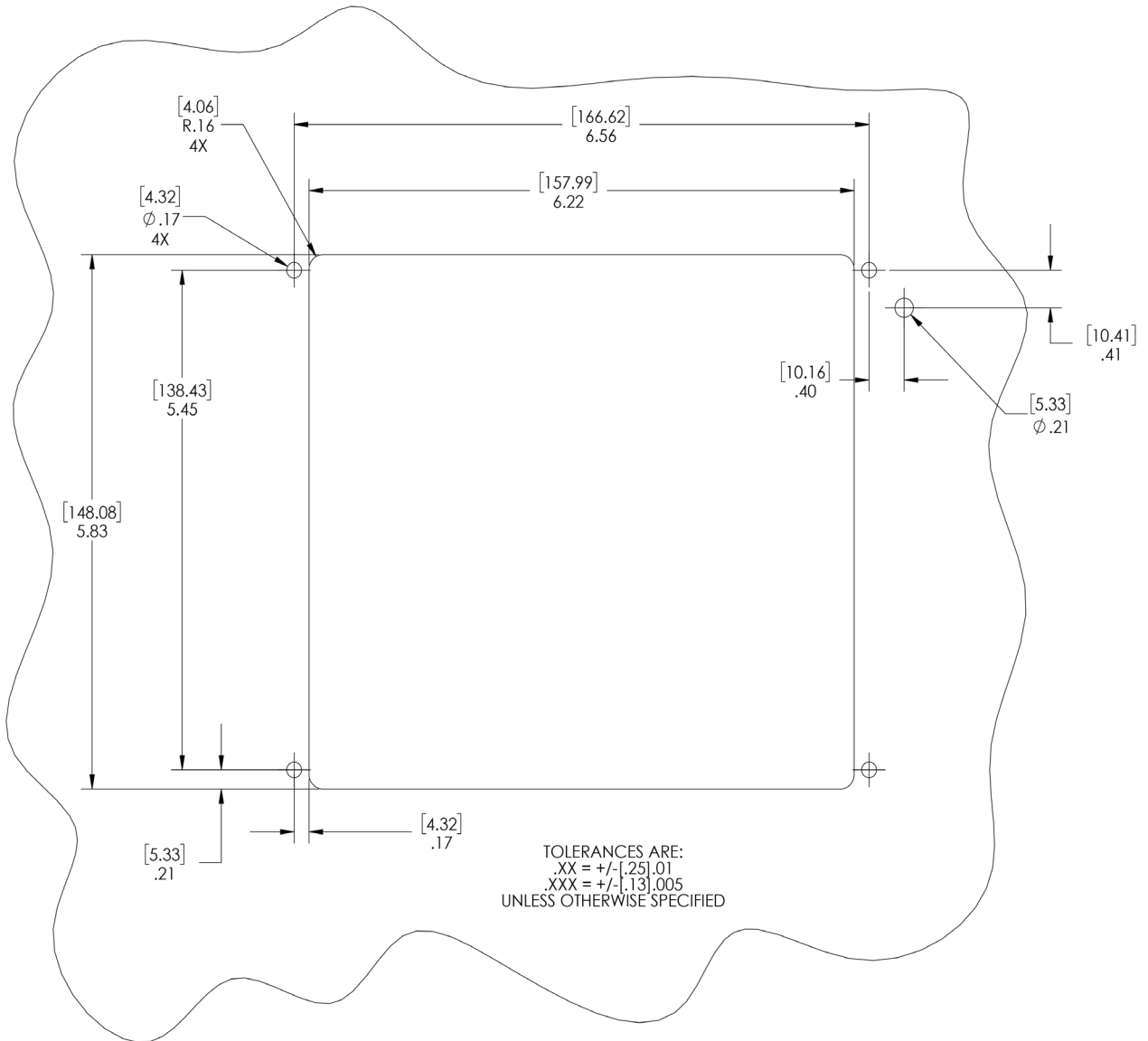

RECEIVER PANEL CUTOUT

G10X PART #'S 310104482

**For the most up-to-date and detailed information consult the product drawing available at vpc.com*

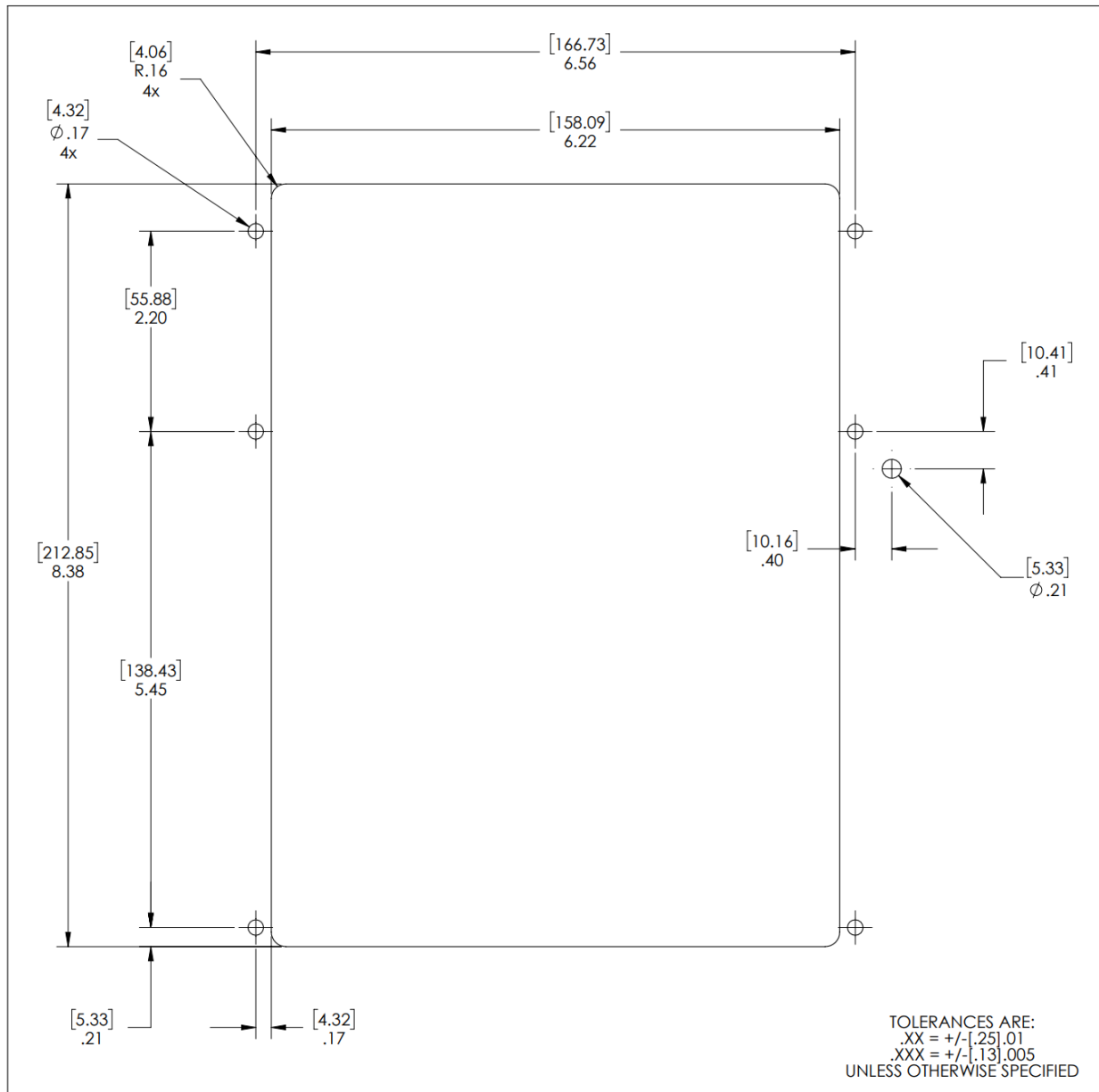

SLIDE MOUNT NOTATION REGARDING U HEIGHT

PART # 310104419, 310120100, 310120146, 310120158, 310120208

The slide mechanism protrudes downward into the next U height on both sides of the receiver.

Measurements can vary per receiver.

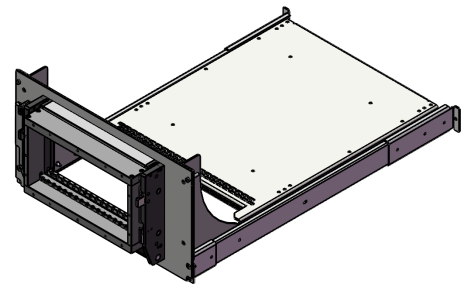
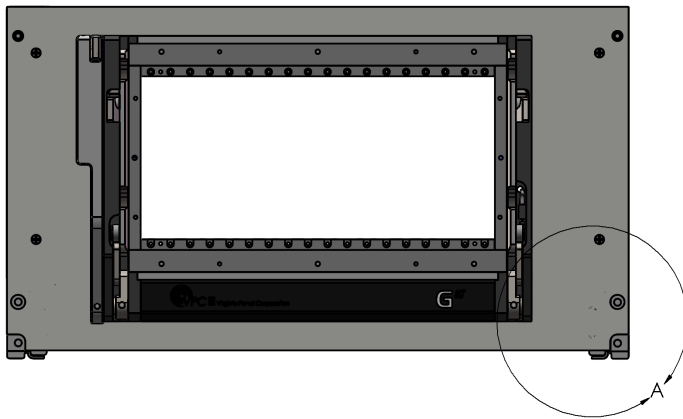

Part Number	DIM A
310 104 419	.25 [6.4]
310 120 100	.25 [6.4]
310 120 146	.25 [6.4]
310 120 158	.25 [6.4]
310 120 208	.25 [6.4]

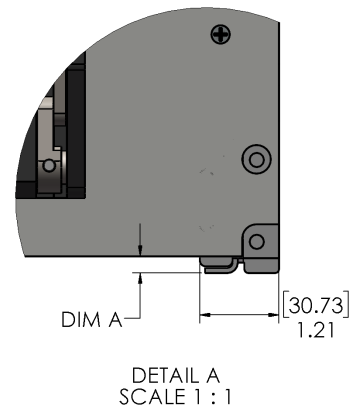

PRECAUTIONARY NOTES

- It is advisable that power to the interface system be disconnected prior to handling and maintenance.
- Never probe a contact without using a mating patchcord as a test lead.
- Never forcefully engage a system if there is an excessive amount of resistance on the handle.
- Never allow an ITA to drop as this may cause misaligned engagement and/or irreparable damage.
- When engaging the ITA with the receiver, caution must be taken to ensure that the ITA is parallel with the receiver upon engagement and that the ITA rollers are engaged **at the same time!**
- Caution should always be used when engaging, making sure that all foreign objects and debris are removed from the system.
- Use care when hinging a receiver down. Always maintain hand contact to prevent receiver from dropping suddenly, resulting in damage to the system.

TROUBLESHOOTING

ITA engagement bearings/studs are not lining up with the engagement slots of the receiver

- Check the alignment of the ITA Frame. There is a possibility that the ITA Frame will have misaligned itself if it was dropped. Contact VPC - user adjustments to system, unless authorized, will void warranty.
- Forceful engagement of the receiver and the ITA will result in serious damage to multiple parts of the system (modules, receiver, ITA and contacts).

ITA frame is not lined up when engaging with receiver

- May indicate ITA was dropped and is out of alignment or a module is not mating properly. Remove and inspect the ITA for damage. Contact VPC - user adjustments to system, unless authorized, will void warranty.
- Check for foreign objects/tools that may be obstructing proper engagement.
- Verify the orientation of the receiver and ITA modules.
- Inspect the mating modules to ensure they match. Power ITA module is mating with power receiver module, etc.
- Forceful engagement of the receiver and the ITA will result in serious damage to multiple parts of the system (modules, receivers, ITA and contacts).

Excessive force is needed upon engaging the handle

- Damaged contact(s) can cause noticeable resistance when trying to engage and mate. Inspect all contacts for damage. If a contact is replaced, the mating contact on the opposite side should also be inspected and replaced if necessary.
- Follow all steps above for an unaligned ITA frame, if force is still needed please contact VPC for assistance.

ITA will not engage with the receiver after diagnosing the above problems

- Contact VPC - user adjustments to the system, unless authorized, will void the warranty.

No continuity upon engagement

- If replacing a contact on the ITA, the mating contact on the receiver side should also be inspected and replaced if necessary.
- Check wiring - replace if necessary.
- Check that all contacts are secured in modules.
- Verify that any 50 OHM ITA contacts are not engaged with 75 OHM receiver contact. This will damage the 75 OHM contact.
- Any 75 OHM ITA contact engaged with 50 OHM receiver contact will not create continuity/contact.

A "short" in the wiring upon engagement

- A damaged contact(s) can cause noticeable resistance when trying to engage and mate. Inspect all contacts for damage. If a contact is replaced, the mating contact on the opposite side should also be inspected and replaced if necessary.
- Check wiring - replace if necessary.

Receiver and ITA will not disengage

- This may indicate that the engagement mechanism within the receiver is faulty - contact VPC immediately. User adjustments to system, unless authorized, will void the warranty.

MICROSWITCH REPLACEMENT

PART # 310113180

This microswitch is compatible with some G2, G6 and G10 receivers. A microswitch alerts users as to the presence of an engaged ITA in the system.

This microswitch (p/n 310113180) is intended for sale and use as a replacement only. G2, G6, and G10 receiver models originally sold without the microswitch installed, cannot have a microswitch added following purchase. While holes are located in the correct position on the receiver frame for the possible addition of a microswitch, these holes are not configured correctly to accommodate microswitch installation. Use of a microswitch requires a receiver model that includes a microswitch pre-installed at the time of purchase.

Receiver Model	G2	G6	G10
Cannot Use Microswitch*	310120110	310104318, 310104344, 310104419	310104317, 310120146
Include Microswitch*	310120112	310104336	310104335

* please note: This is not intended to be a complete list of part numbers and is not a guarantee of part availability or life cycle status. More information is available on vpc.com.

1. There are four slots machined into the receiver beside the two engagement slides that accept the ITA rollers. Locate the large slot along the top of the right engagement slide (**Figure A**).
2. Place the microswitch in the slot, feeding the wires through the hole provided (**Figure B**).
3. Attach the microswitch using the two screws provided. The mounting holes are located in the side of the receiver. One can be accessed with the handle in the open position, and the other with the handle in the closed position.
4. Wire the microswitch, as desired. Wire color codes included on the receiver drawing.



DISCONNECT ALL ELECTRICAL SUPPLIES TO THE SYSTEM PRIOR TO INSTALLATION OF MICROSWITCH.

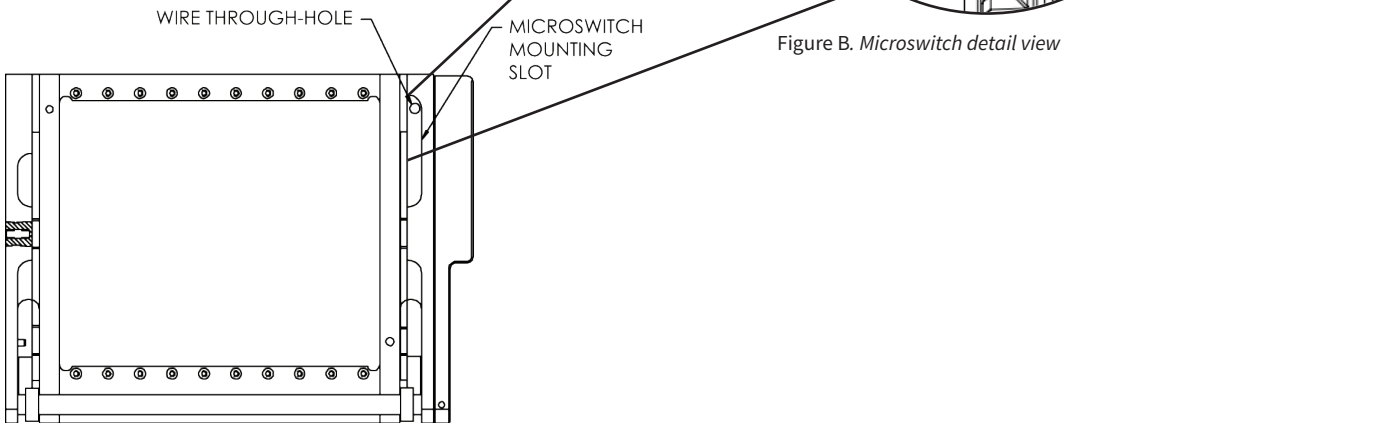

Figure A. Front of receiver.

Figure B. Microswitch detail view

REMOVAL AND REPLACEMENT OF DOWEL/ ALIGNMENT PINS

KIT PART# 310118000

Parts/ Tools Required:

Dowel Pin Replacement Kit p/n 310118000, includes:

- Loctite Primer
 - Loctite Adhesive
 - Two $\frac{5}{32}$ " Dowel Pins
 - Dimension Block
- $\frac{1}{8}$ " Drive Pin Punch**

NOTE: Figures shown represent VPC's G6 receiver. The dowel pin locations for the G2 and G10 are similar.

REMOVAL

1. Remove all modules from the receiver.
2. Turn over the receiver to the back side.
3. Place supports under the receiver's front face so that the dowel pins may be pushed out past the face of the receiver.
4. Using a $\frac{1}{8}$ " drive pin punch, press the dowel pins out of each hole.
5. Return the receiver to the face-up position.

REPLACEMENT

6. Spray the provided Loctite primer onto one of the dowel pins.
7. Cover the bottom $\frac{3}{8}$ " of the pin with the provided Loctite adhesive.
8. Begin to insert that dowel pin into one of the dowel pin insertion holes on the front of the receiver (**Figure B**).
9. Place the supplied dimension block over the dowel pin and press the pin until it is flush with the dimension block.
10. Wipe off any excess Loctite.
11. Repeat steps 6-10 using the second dowel pin.

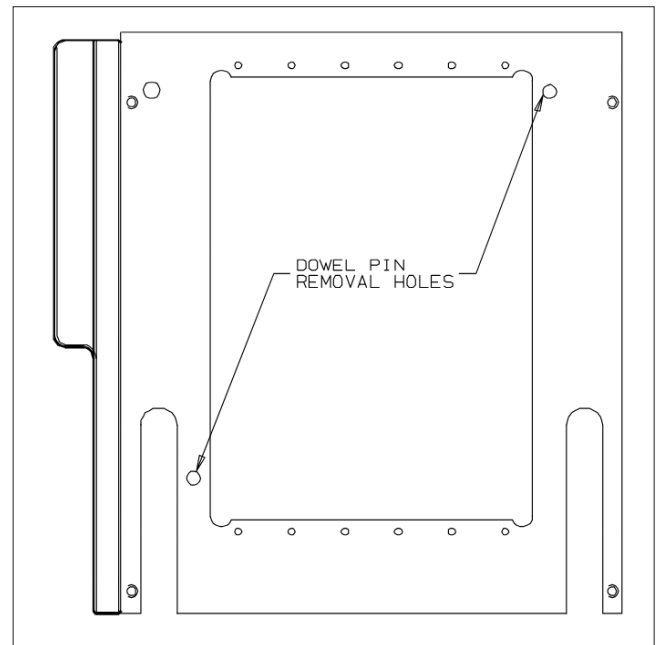

Figure A. Back side of receiver

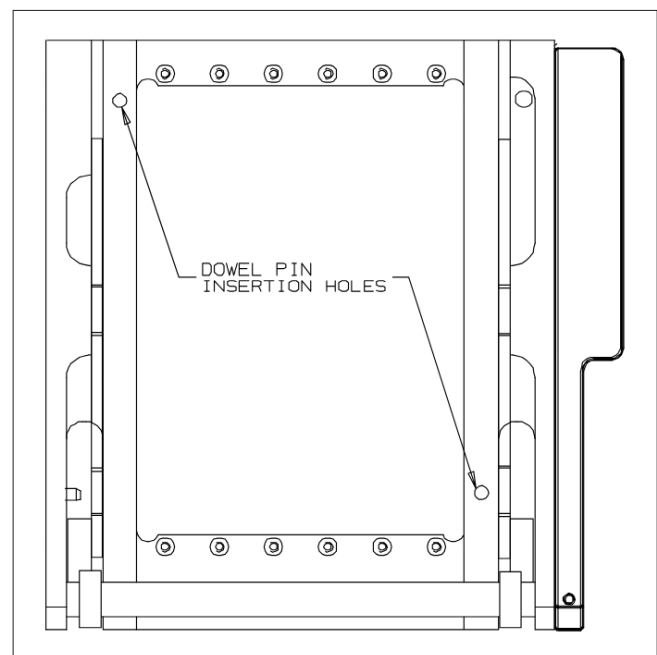

Figure B. Front side of receiver.

[RETURN TO INDEX](#)