



i2 MICRO iCON USER MANUAL

INDEX *(CLICK TO NAVIGATE TO PAGE)*

PAGE

- 1 [RECEIVER PART IDENTIFICATION](#)
- 2 [ITA PART IDENTIFICATION](#)
- 3 [RECEIVER/ITA ENGAGEMENT & DISENGAGEMENT](#)
- 4 [RECEIVER MOUNTING](#)
- 5 [ITA COVER REMOVAL](#)
- 6 [ITA COVER INSTALLATION](#)
- 8 [CABLE CLAMP REMOVAL & INSTALLATION](#)
- 9 [CONTACT REMOVAL](#)
- 10 [RECEIVER STRAIN RELIEF ASSEMBLY](#)
- 11 [RECEIVER PROTECTIVE COVER INSTALLATION](#)
- 12 [ITA PROTECTIVE COVER INSTALLATION](#)
- 13 [KEYING PIN KIT, RECEIVER & ITA ASSEMBLY](#)
- 14 [PCB ASSEMBLY W/ TWO HEADERS](#)
- 15 [PCB LAYOUT W/ HEADER](#)
- 16 [STANDARD PCB LAYOUT](#)
- 17 [HYBRID PCB LAYOUT W/ HEADER](#)
- 18 [HYBRID STANDARD PCB LAYOUT](#)
- 19 [TROUBLESHOOTING](#)

*Please note that any printed or downloaded User Manuals may not reflect the most current revisions.
The information contained in this material is subject to change.
The most current information available will be on vpc.com.*

RECEIVER PART IDENTIFICATION

PART # 310130XXX

(**Figure A**) notes distinguishing features of the i2 Micro iCon receiver for identification of the top and bottom of the receiver. Features to look for are the numeric keying receptacle on the top side and the alpha keying receptacle on the bottom.

The front and rear of the receiver are shown in (**Figure B**). The front has a polarizing feature which prevents the i2 Micro iCon ITA and receiver from being engaged upside down. The front of the receiver can be identified as the side with the latching feature.

NOTE: The i2 Micro iCon is the only product in VPC's iSeries product line that features a receiver that acts as the module. All other products feature modules that are independent from the receiver or ITA.

The front side mates with the ITA. Wires exit the receiver from the rear side.

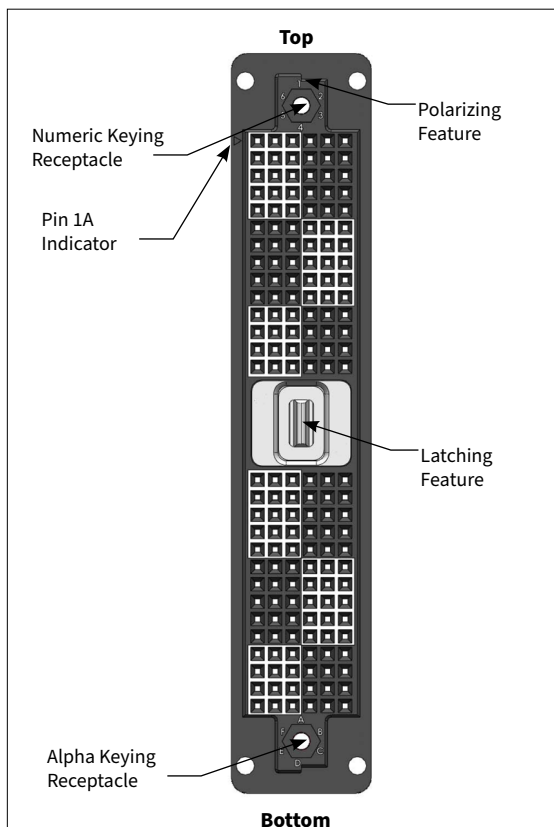

Figure A. i2 Micro iCon receiver front view.

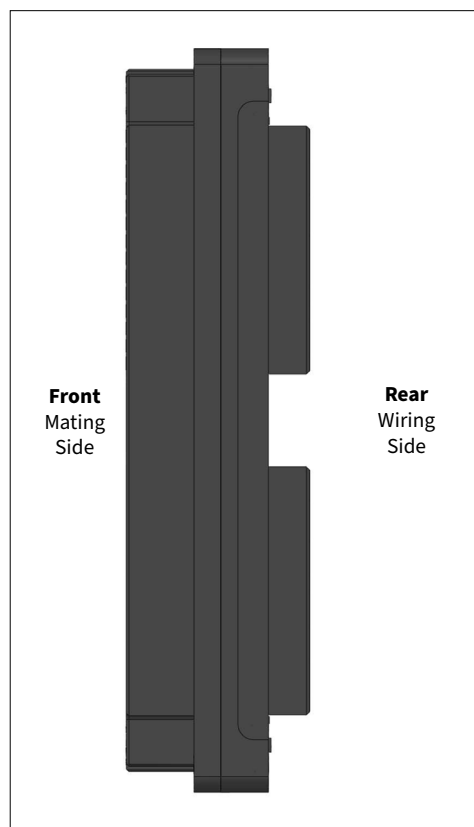

Figure B. i2 Micro iCon receiver side view.

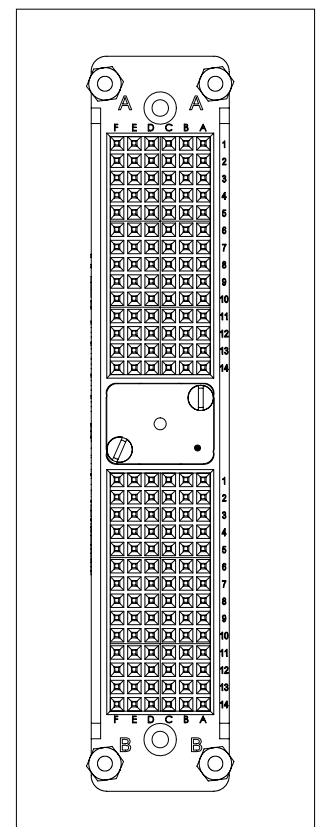

Figure C. Pin location layout.

[RETURN TO INDEX](#)

ITA PART IDENTIFICATION

PART # 410130XXX

(**Figure A**) points out distinguishing features of the i2 Micro iCon ITA so that the top and bottom can be identified. Features to look for are the numeric keying receptacle on the top side and the alpha keying receptacle on the bottom.

The front and rear of the ITA are easily distinguished as shown in (**Figure B**). The front has a protruding guide plate with locking tabs and the rear has the knob.

The front side mates with the i2 Micro iCon receiver. The front has a polarizing feature which prevents the ITA and receiver from being engaged upside down. Wires exit the ITA through the 30° cable exit.

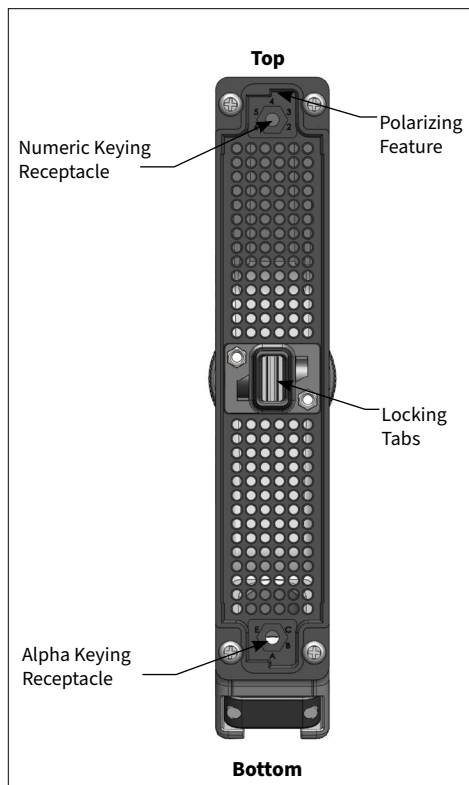

Figure A. i2 Micro iCon ITA front view.

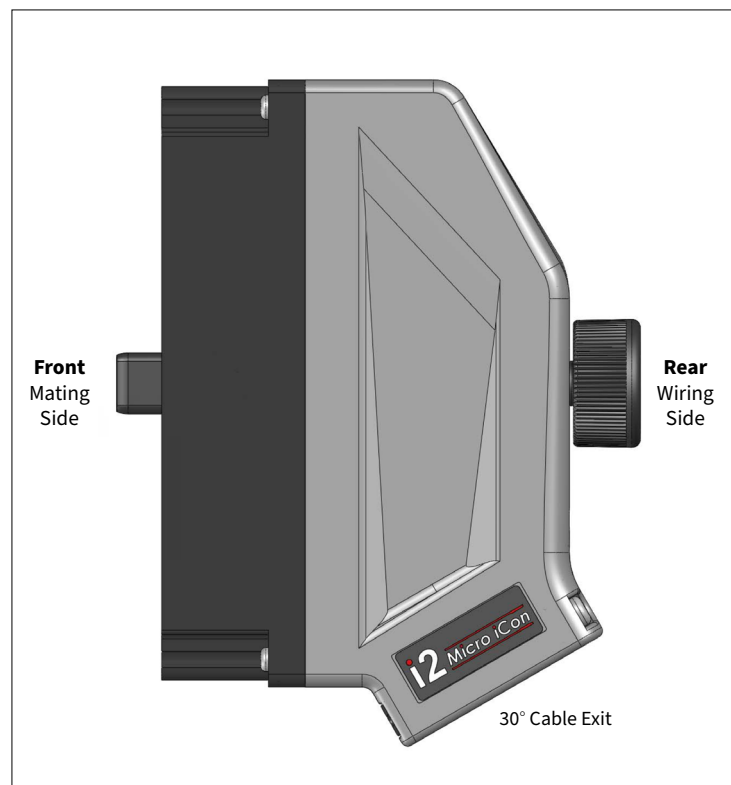

Figure B. i2 Micro iCon ITA side view.

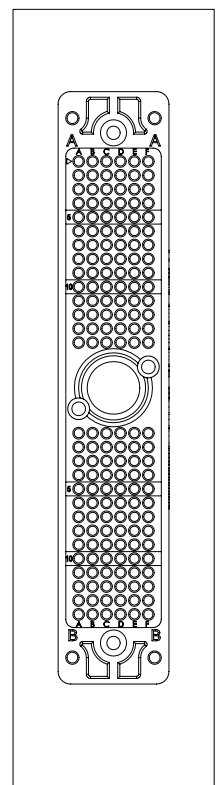

Figure C. Pin location layout.

[RETURN TO INDEX](#)

RECEIVER/ITA ENGAGEMENT AND DISENGAGEMENT

RECEIVER • PART # 310130XXX

ITA • PART # 410130XXX

ENGAGEMENT INSTRUCTIONS

1. Turn the engagement knob counter-clockwise to the open/disengaged position (**Figure A**).
2. Align the i2 Micro iCon ITA with the receiver and gently push the ITA onto the receiver. There will be about a 0.25" [6.35 mm] gap.

NOTE: The ITA is polarized and will not align if it is upside down.

NOTE: The ITA can be left in this position without engaging the system.

3. Rotate the engagement knob clockwise to engage (**Figure B**).

NOTE: For optimum performance and system longevity, distribute the contact load evenly. Two-hand support during engagement is recommended.

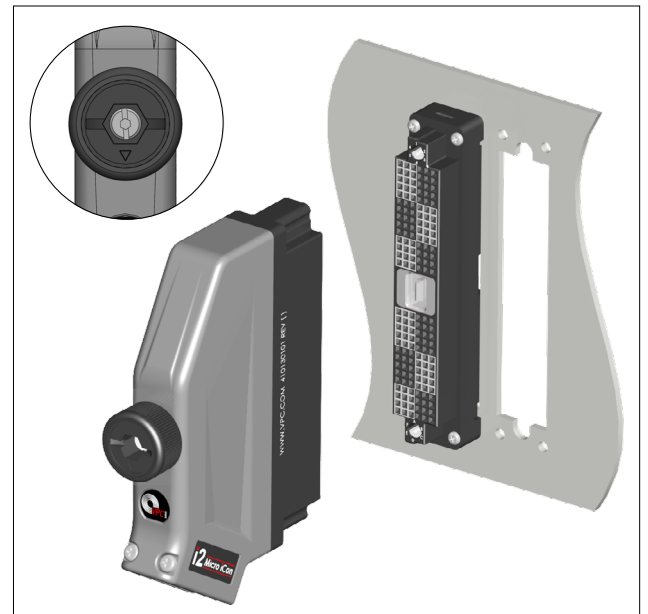

Figure A. Disengaged ITA and receiver.

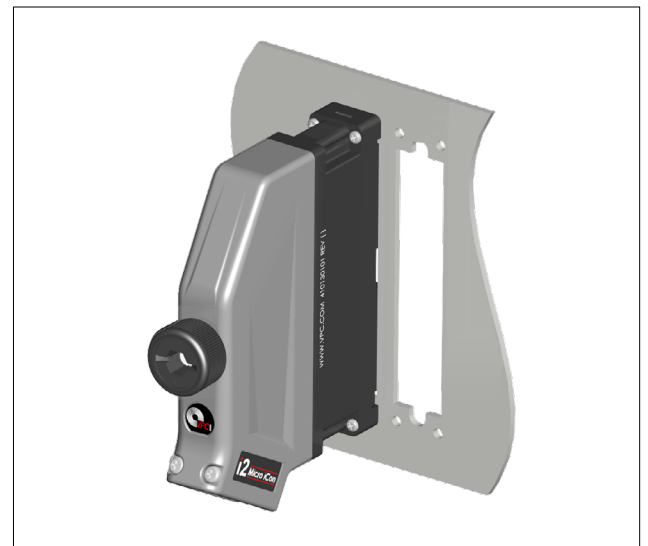

Figure B. Engaged ITA and receiver.

DISENGAGEMENT INSTRUCTIONS

1. Turn the engagement knob counter-clockwise to the open/disengaged position (**Figure A**).
2. Remove the ITA by gently pulling backwards.

NOTE: For unbalanced loads, add force to the lower pin load during disengagement to prevent binding.

[RETURN TO INDEX](#)

RECEIVER MOUNTING

PART # 310130XXX

TOOLS REQUIRED

Phillips Head Screwdriver

MOUNTING INSTRUCTIONS

1. Prepare the mounting surface using the dimensions provided in **(Figure A)**.
2. Attach the i2 Micro iCon receiver to the panel with the provided 2-56 Phillips head screws and nuts **(Figure B)**. Torque screws to 2 in-lbs [0.23 Nm].

NOTE: If the mounting surface is thicker than 0.125" [3.18 mm], longer screws may be needed.

NOTE: If the mounting surface has threaded holes, the nuts will not be needed.

NOTE: M2 hardware can be used in place of the provided 2-56 hardware.

5

NOTE: The dimensions shown reflect use of a laser cutting or punch press process. If using conventional machining processes the 3.49" [88.65] dimension will be 3.69" [93.73] and a .09" [2.29] radius needs to be added to the corners.

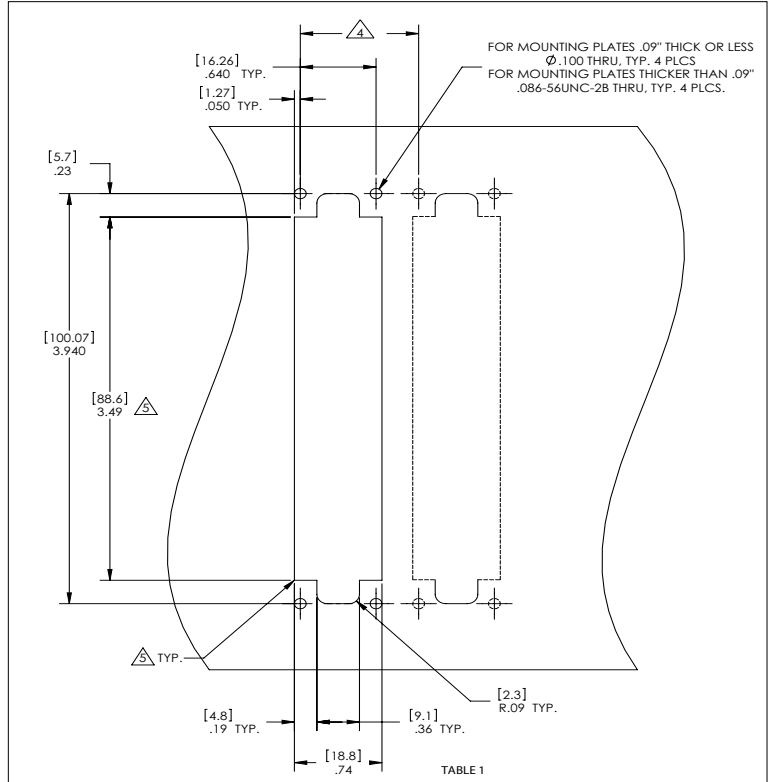

Figure A. Recommended panel cutout.

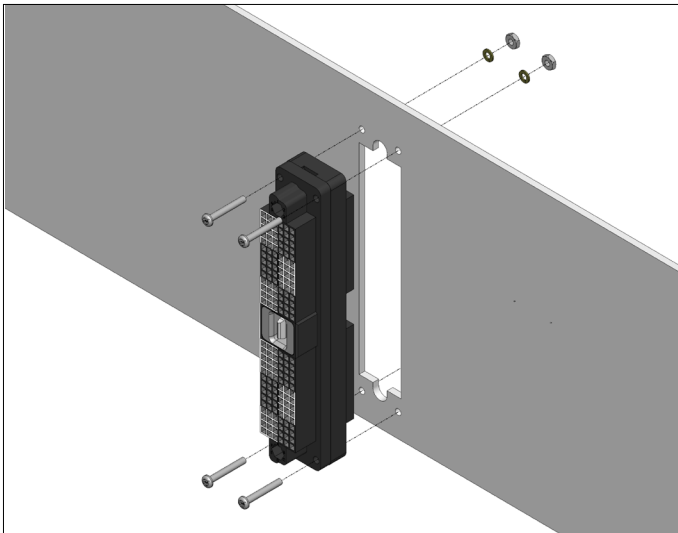

Figure B. If metric hardware is preferred, the supplied 2-56 hardware can be replaced with M2 hardware.

PART NUMBER	DESCRIPTION	RECOMMENDED RECEIVER CUT-OUT SPACING	MINIMUM RECEIVER CUTOUT SPACING
410130101	ITA, i2 Micro iCon, 168 Position	1.75 [44.45]	1.00 [25.40]
410130104	ITA, i2 Micro iCon, 120/12 Position Hybrid	1.75 [44.45]	1.00 [25.40]
410130106	ITA, i2 Micro iCon, 168 Position with Oversized Backshell	1.75 [44.45]	1.75 [44.45]
410130109	ITA, i2 Micro iCon Quadrax/TP	1.75 [44.45]	1.00 [25.4]
410130115	ITA, i2 Micro iCon, 120/12 Position Hybrid with Over-sized Backshell	1.75 [44.45]	1.75 [44.5]
410130118	ITA, i2 Micro iCon Quadrax/TP	1.75 [44.45]	1.00 [25.4]
410130124	ITA, i2 Micro iCon 168 Position	1.75 [44.45]	1.00 [25.4]

[RETURN TO INDEX](#)

ITA COVER REMOVAL

PART # 410130XXX

TOOLS REQUIRED

Phillips Head Screwdriver
Flat Head Screwdriver

REMOVAL INSTRUCTIONS

1. Disengage the i2 Micro iCon ITA from the receiver.
2. If the ITA is wired, remove the cable clamp/strain relief bar (see page 8 of this user manual).
3. Using a flat head screwdriver, remove the engagement knob screw and engagement knob (**Figure A**).
4. Using a Phillips head screwdriver, loosen the four screws (captive) that secure the cover to the ITA/module (**Figure B**).
5. Slide the cover down (**Figure C**) so that the insert clears the bottom of the ITA/module.
6. Remove the insert from the cover by sliding it toward the mating face of the ITA/module (**Figure C**).
7. Remove the cover from the ITA/module (**Figure D**).

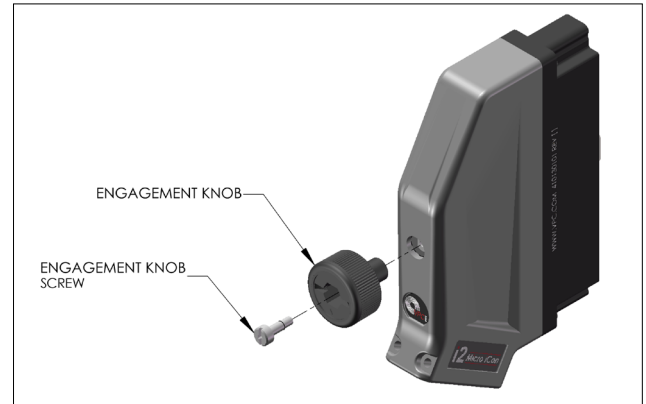

Figure A. Remove engagement knob.

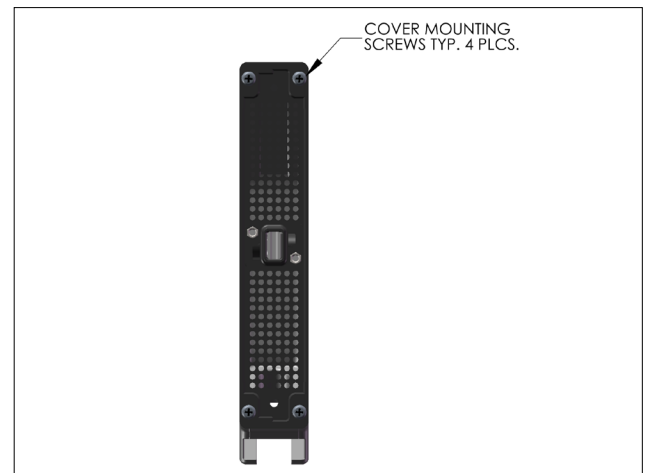

Figure B. Loosen cover mounting screws.

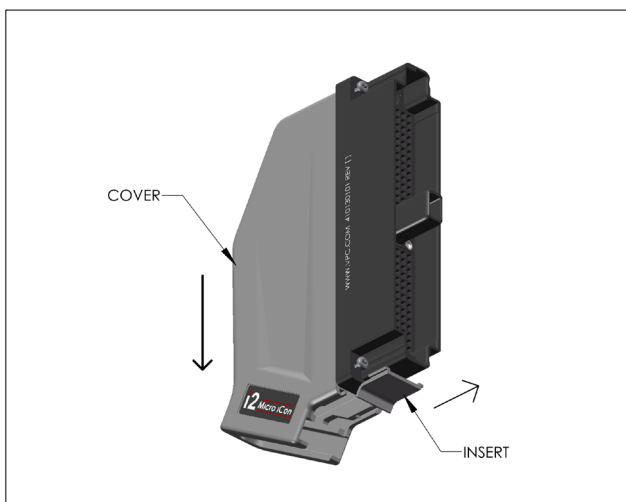

Figure C. Remove insert from cover.

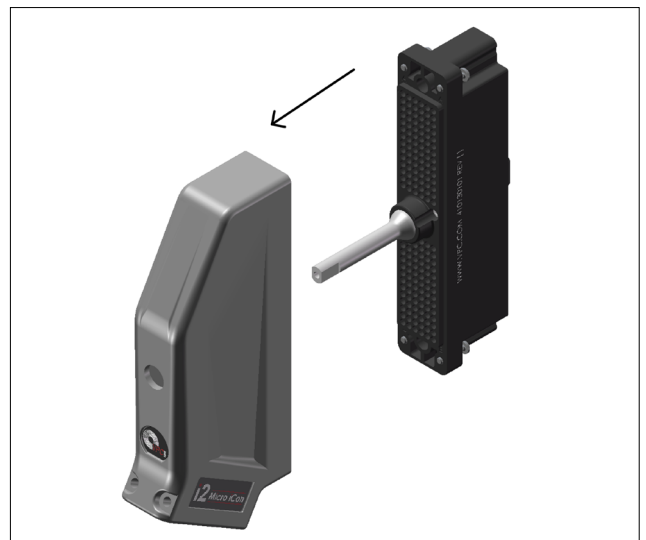

Figure D. Remove cover.

[RETURN TO INDEX](#)

ITA COVER INSTALLATION

PART # 410130XXX

TOOLS REQUIRED

Phillips Head Screwdriver
Flat Head Screwdriver

INSTALLATION INSTRUCTIONS

1. With the needed wires/contacts installed in the i2 Micro iCon ITA/module, distribute the wires evenly around the drive shaft (**Figure A**).
2. Place the cable bundle in the U-shaped cable clamp portion of the cover and position the cover against the wiring side of the ITA/module (**Figure B**).
3. With the cover against the wiring side of the ITA/module, slide the cover down so that the slot for the cover insert clears the bottom of the ITA/module (**Detail A in Figure C**).
4. Slide the insert into the cover in the orientation shown (**Figure C**).

Continued on next page...

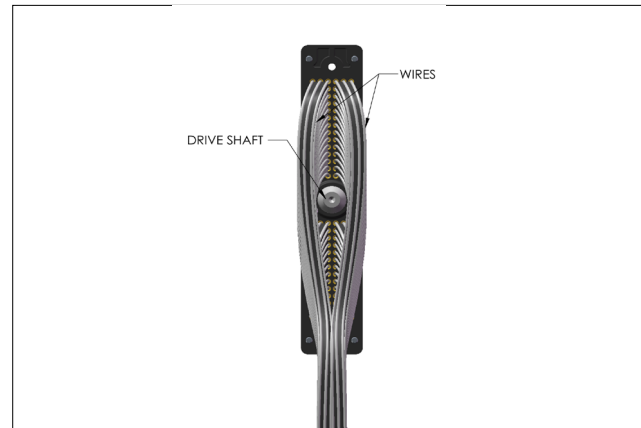

Figure A. Distribute wires evenly around drive shaft.

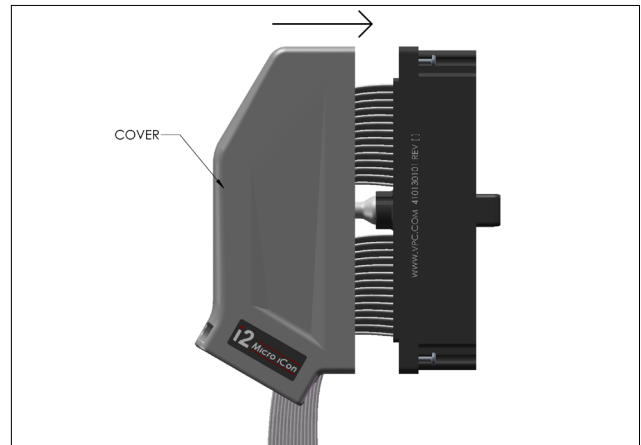

Figure B. Position cover.

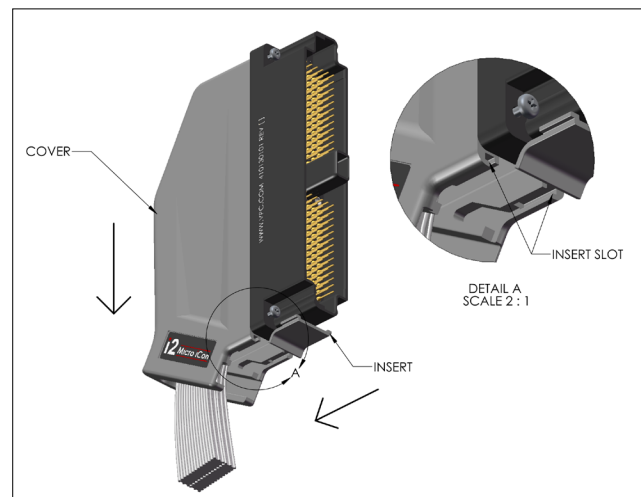

Figure C. Slide cover down and install insert.

[RETURN TO INDEX](#)

ITA COVER INSTALLATION

PART # 410130XXX

INSTALLATION INSTRUCTIONS (CONT'D)

5. Secure the cover to the i2 Micro iCon ITA/module by tightening the four Phillips head screws (**Figure D**) in a criss cross pattern using a Phillips head screwdriver. Torque to 2 in-lbs [0.23 Nm].
6. Install the engagement knob and tighten the engagement knob screw using a flat head screwdriver (**Figure E**). Torque to 4 in-lbs [0.46 Nm].
7. Secure the cable bundle using the strain relief bar. (See page 8 of this user manual for more information.)

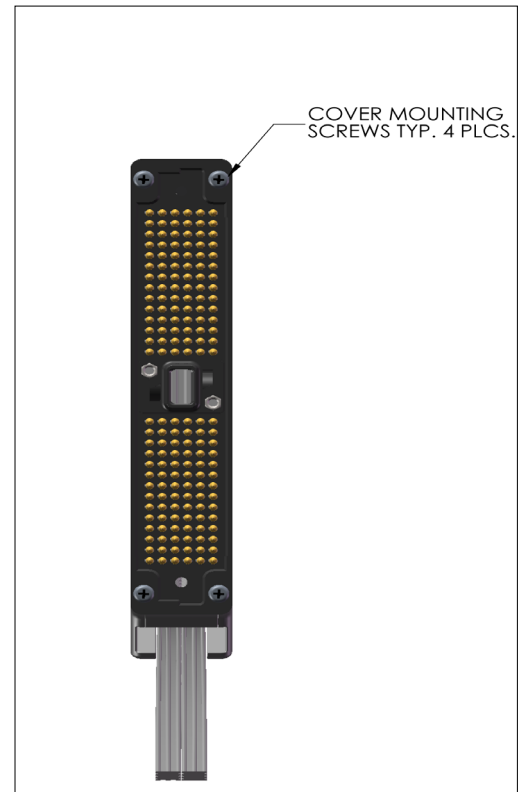

Figure D. Secure cover to ITA/module.

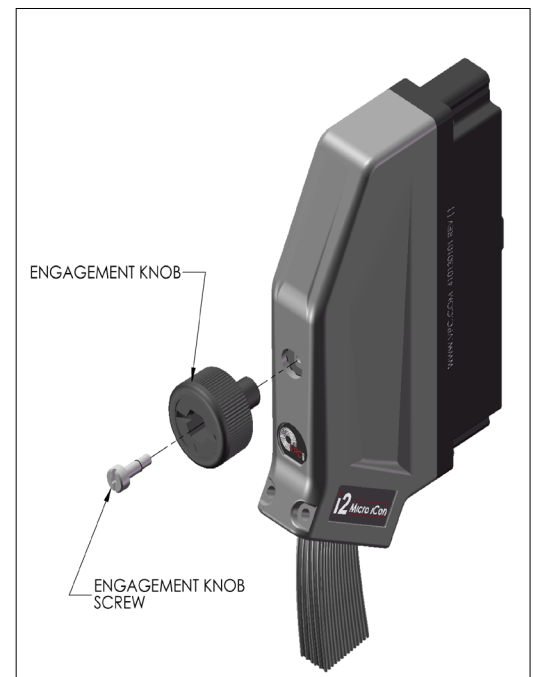

Figure E. Reinstall engagement knob.

[RETURN TO INDEX](#)

CABLE CLAMP REMOVAL AND INSTALLATION

PART # 410130XXX

TOOLS REQUIRED

Phillips Head Screwdriver

REMOVAL INSTRUCTIONS

1. Remove the two 4-40 x 1.5" screws and strain relief bar from the i2 Micro iCon ITA cover (**Figure A**).

INSTALLATION INSTRUCTIONS

1. Install the two 4-40 x 1.5" screws and strain relief bar from the ITA cover (**Figure A**).
2. Slowly alternate tightening the 4-40 x 1.5" screws until the strain relief bar is snugly against the cable bundle (**Figure B**).

NOTE: Reverse the orientation of the strain relief bar to accommodate smaller cable bundles.

FORMULA TO CALCULATE THE MAXIMUM NUMBER OF WIRES IN A CABLE BUNDLE

$$B = 1.2 \sqrt{(N_1 d_1^2 + N_2 d_2^2 \dots + N_n d_n^2)}$$

B = Wire Bundle Diameter	N_1 = Quantity of first wire type	d_1 = Outside Diameter of first wire type
	N_2 = Quantity of second wire type	d_2 = Outside Diameter of second wire type
	N_n = Quantity of n^{th} wire type	d_n = Outside Diameter of n^{th} wire type

WIRE TYPE	Ø [in]	# WIRES	BUNDLE Ø [in]
26AWG 16878/4	0.043	221	0.77
24AWG 16878/4	0.048	177	0.77
22AWG 16878/4	0.054	141	0.77
M27500-26m12t08	0.114	31	0.76
M27500-24m12t08	0.126	26	0.77
M27500-22m12t08	0.140	21	0.77
M27500-22m11t08	0.087	54	0.77
22AWG 16878/4 T/P	0.108	35	0.77
24AWG 16878/4 T/P	0.096	44	0.76

NOTE: Acceptable bundle dimension must be reduced when using sleeving and shrink tubing.

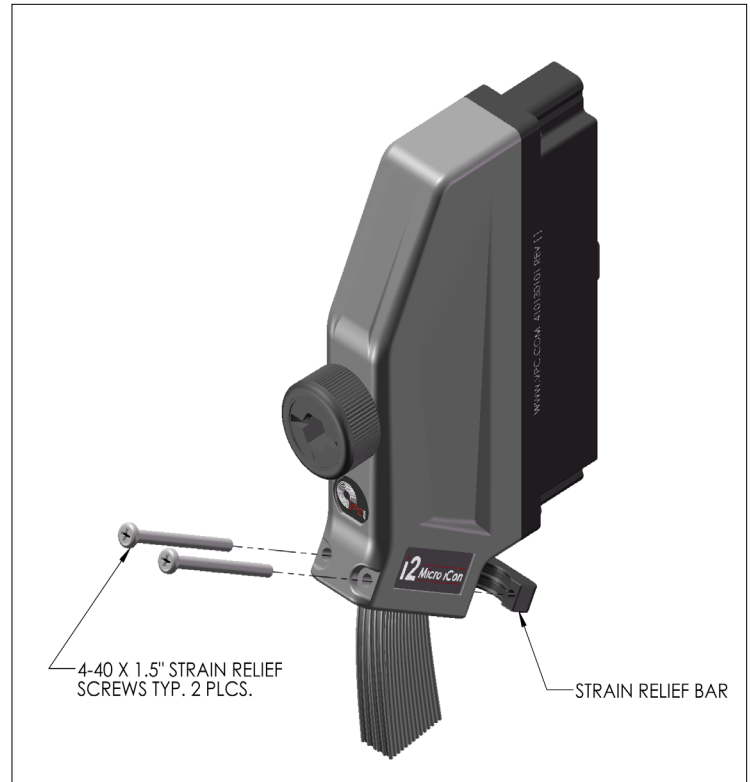

Figure A. Removal/Installation of the strain relief bar.



Figure B. Cable clamp exit area.

[RETURN TO INDEX](#)

CONTACT REMOVAL

PART # 310130XXX / 410130XXX / 610138109 / 610138112 / 610138200 / 610138216 / 610140XXX / 610141XXX / 610142101 / 610143101

TOOLS REQUIRED

Phillips Head Screwdriver
Flat Blade Screwdriver

RECEIVER INSTRUCTIONS

1. Remove the strain relief or keying pins (refer to page 11 of this user manual) if needed.
2. Using the Phillips head screwdriver, remove the four panel mounting screws from the top and bottom of the i2 Micro iCon receiver (**Figure A**).
3. Using the flat head screwdriver, remove the two flat head assembly screws from the back of the receiver (**Figure A**).
4. Insert the flat blade screwdriver into the slot on the top of the receiver and pry the end of the receiver using a twisting motion until visible separation is indicated. Repeat on the opposite end of the receiver.
5. Grasp the receiver halves and apply force in opposite directions, rocking the ends of the receiver while slightly pulling the front of the receiver away from the mating back section. Be sure to open both sides of the receiver simultaneously or contacts could be damaged.
6. Extract the signal contact per the QuadraPaddle User Manual. Reference contact part # 610138200 for receiver part # 310130101 or contact part # 610138216 for receiver part # 310130102.

For Hybrid Receivers (Part # 310130104 or 310130105):

7. Extract the power contact per the Micro Power User Manual. Reference contact part # 610142101.
8. Extract the Coax contact per the Micro Coax User Manual. Reference contact part # 610140XXX.

ITA INSTRUCTIONS

1. Refer to page 5 for i2 Micro iCon ITA cover removal instructions.
2. Extract the signal contacts per the QuadraPaddle User Manual. Reference contact part # 610138109 or 610138112.

For Hybrid ITA (Part # 410130104):

3. For extraction, use the Micro Power/Micro Coax extraction tool part # 910112127. Extract the power contact per the Micro Power User Manual. Reference contact part # 610143101.
4. For extraction, use the Micro Power/Micro Coax extraction tool part # 910112127. Extract the coax contact per the Micro Coax User Manual. Reference contact part # 610141XXX.

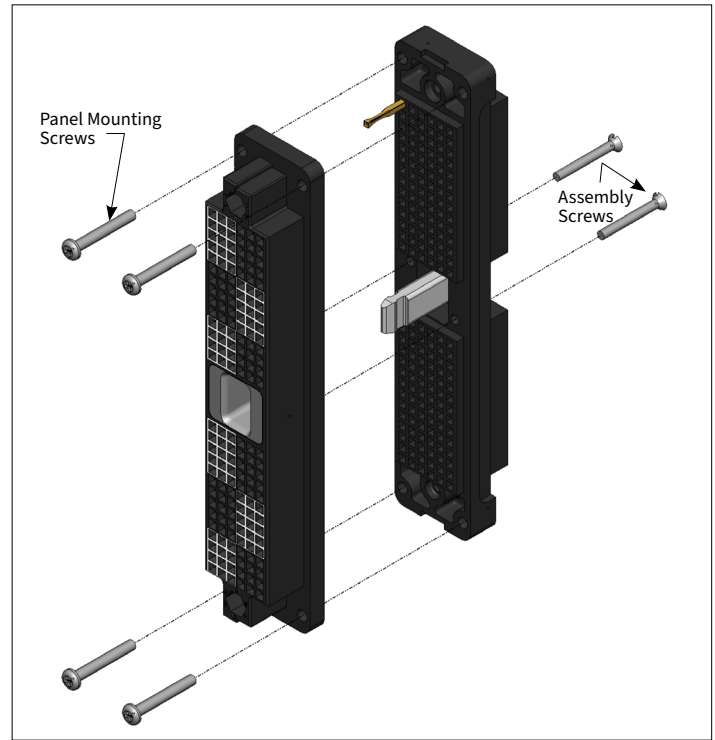

Figure A. i2 Micro iCon Receiver separation.

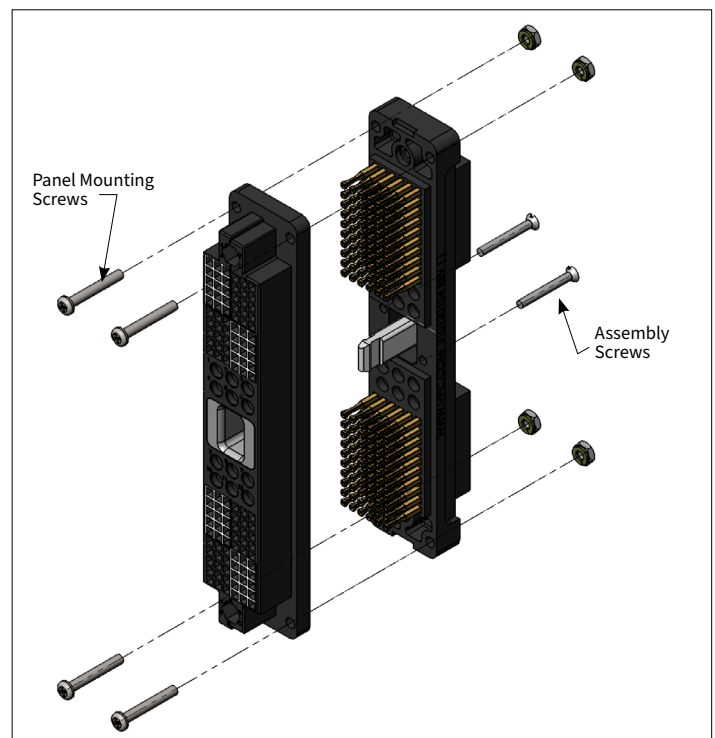

Figure B. i2 Micro iCon Hybrid receiver separation.

[RETURN TO INDEX](#)

RECEIVER STRAIN RELIEF ASSEMBLY

PART # 310113559

TOOLS REQUIRED

Phillips Head Screwdriver

ASSEMBLY INSTRUCTIONS

1. Using the Phillips head screwdriver, fasten the strain relief to the back (wiring) side of the i2 Micro iCon receiver with the 2-56 screws and nuts provided (**Figure A**). Place the nuts in the keying positions from the front side of the receiver.

NOTE: If using the keying features, replace the 2-56 nuts with the keying pins (**Figure B**).

2. Torque screws to 2 in-lbs [0.23 Nm].

NOTE: Four wiring ties are included with the strain relief for restraining wires.

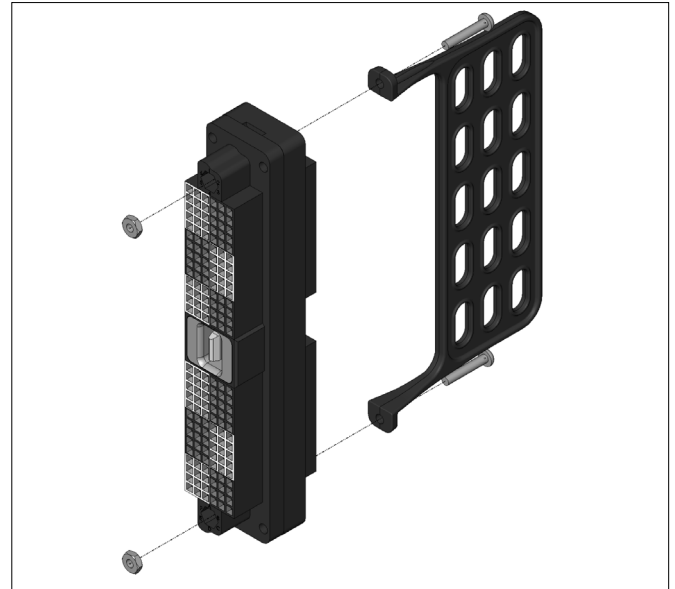

Figure A. i2 Micro iCon receiver strain relief.

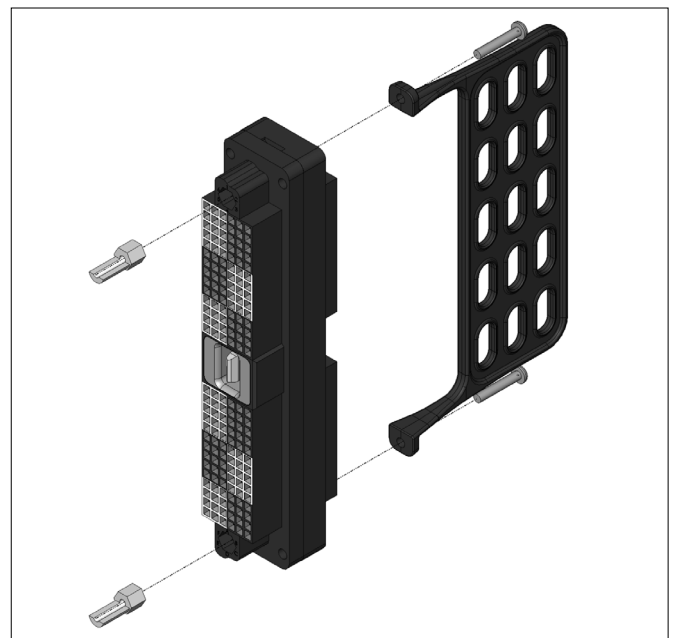

Figure B. i2 Micro iCon receiver strain relief with keying pins.

[RETURN TO INDEX](#)

RECEIVER PROTECTIVE COVER INSTALLATION

PART # 310113667

INSTALLATION INSTRUCTIONS

1. To attach the i2 Micro iCon receiver protective cover to the receiver, you may discard the mounting screw that is supplied with the cover.
2. Use the eyelet coupling on the cover's chain lanyard to attach the cover to the receiver. Place the 2-56 bottom right mounting screw used to mount the receiver to the panel, through the eyelet coupling.
3. Secure the mounting screw and nuts to the receiver. The eyelet should now be securely mounted between the screw head and receiver. (**Figure B**).

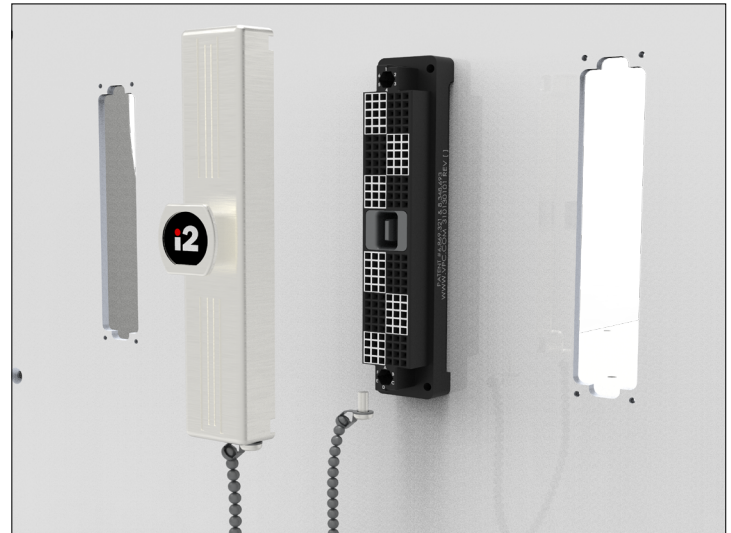

Figure A.

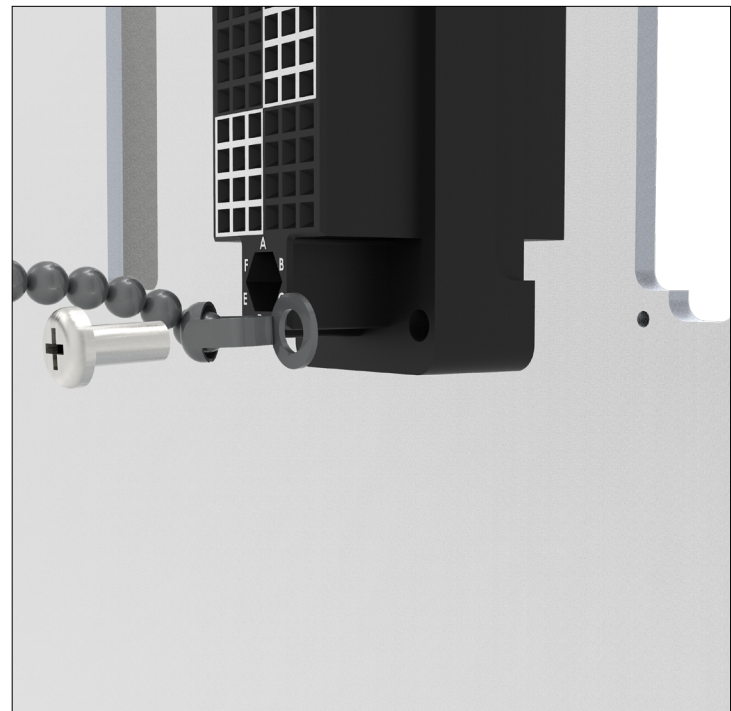

Figure B.

[RETURN TO INDEX](#)

ITA PROTECTIVE COVER INSTALLATION

PART # 410113208

INSTALLATION INSTRUCTIONS

1. To attach the i2 Micro iCon ITA protective cover to the ITA you may discard the mounting screw that is supplied with the cover.
2. Use the eyelet coupling on the cover's chain lanyard to attach the cover to the ITA. Place one of the 4-40 x 1.5" screws through the eyelet and insert into the ITA.
3. Follow the instructions for "Cable Clamp Installation" on page 8 of this User Manual to properly tighten and install the cable clamp.
4. When properly installed the eyelet should be securely mounted between the screw head and ITA housing. **(Figure A)**.



Figure A.

[RETURN TO INDEX](#)

KEYING PIN KIT, RECEIVER AND ITA ASSEMBLY

PART # 310113461

The iSeries keying kit includes two pins and screws which provide six different keying options. The i2 Micro iCon is designed to accept two kits which increase the keying options to 36.

TOOLS REQUIRED

Phillips Head Screwdriver

ASSEMBLY INSTRUCTIONS

1. Determine the keying pin's desired orientation (**Figure A**).
2. Using a Phillips head screwdriver, secure a keying pin in the i2 Micro iCon receiver with the 2-56 screws provided (**Figure B**). Torque screws to 2 in-lbs [0.23 Nm].

NOTE: If the strain relief plate, Part # 310113559 is being used, replace the screws used to secure the keying pins with the screws included with the strain relief plate.

3. Remove the i2 Micro iCon ITA cover (see page 5 of this user manual).
4. Using a Phillips head screwdriver, secure a keying pin in the ITA with the 2-56 screws provided (**Figure C**). Torque screws to 2 in-lbs [0.23 Nm].
5. Replace the ITA cover (see page 5 of this user manual).

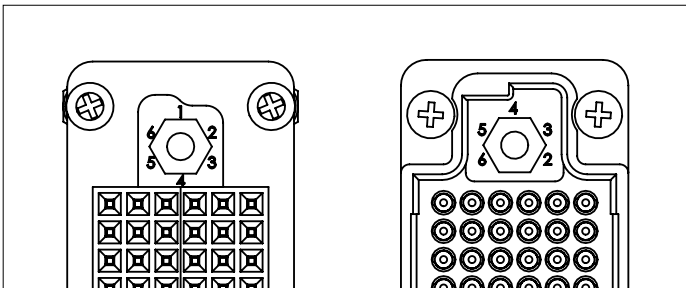

Figure A. i2 Micro iCon receiver and ITA mating faces. In order to mate the connector, the keying pin must be in the same numeric position in both the receiver and ITA.

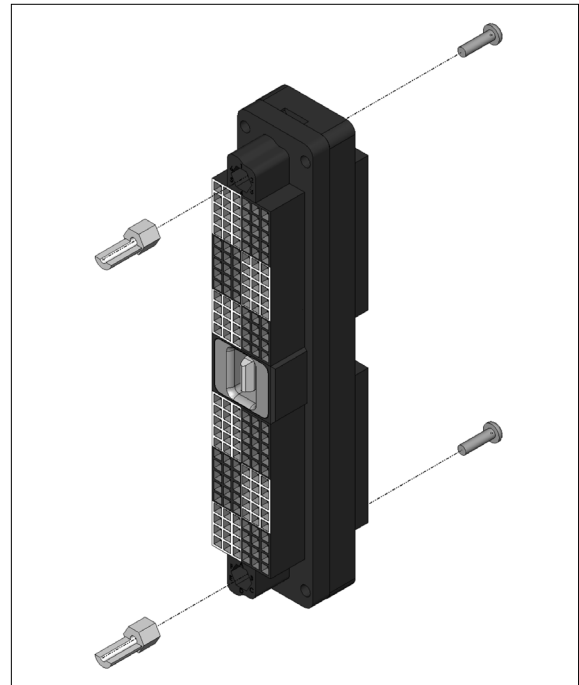

Figure B. i2 Micro iCon receiver with keying pins.

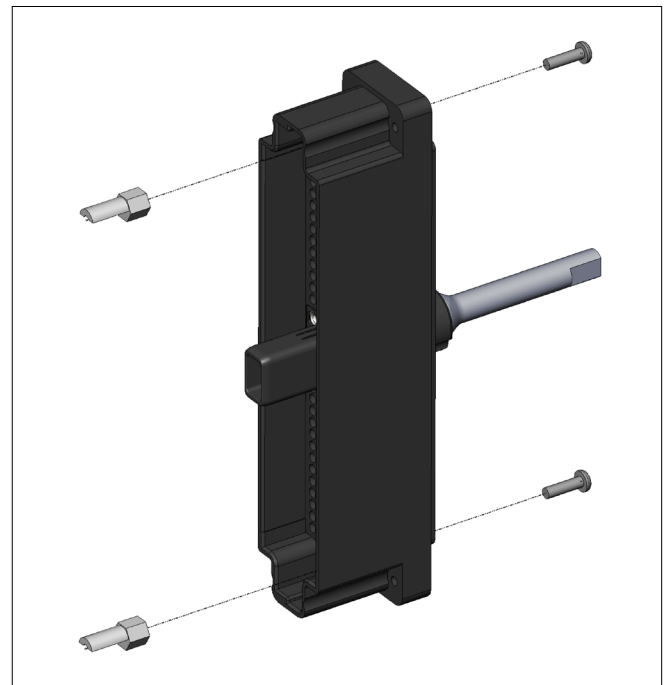

Figure C. i2 Micro iCon ITA with keying pins.

[RETURN TO INDEX](#)

PCB ASSEMBLY

84 PIN HEADER, PART # 510109204 • 60 PIN HEADER, PART # 510109206

MOUNTING BRACKET, PART # 310113562

TOOLS REQUIRED

Phillips Head Screwdriver

ASSEMBLY INSTRUCTIONS

1. Assemble two headers to the PCB. See next page for recommended PCB layout.

NOTE: To ensure a secure connection without damaging the PCB, the board must be properly supported between the mounting holes to distribute pressure evenly. Otherwise, the insertion force may be high enough to damage or break the board. Reference VPC part # 910121199 if a tool is needed.

2. Using the Phillips head screwdriver, secure the headers and mounting bracket (Part # 310 113 562) to the PCB using the supplied 2 mm screws (**Figure A**).
3. Secure the receiver to the mounting panel (**Figure B**) following the recommended panel cutout (see page 4 of this user manual).
4. Using the Phillips head screwdriver, press the PCB and headers onto the receiver and secure the mounting bracket to the receiver using the supplied captive 2-56 screw (**Figure C**).

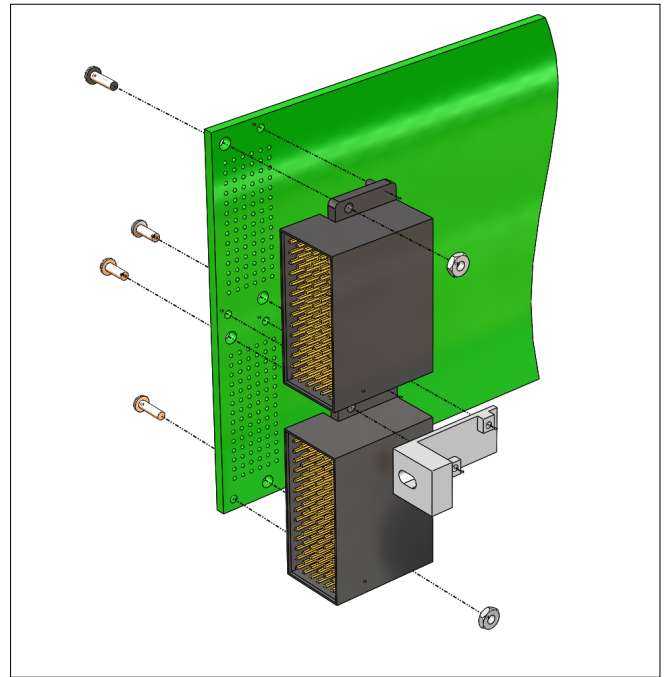

Figure A. Secure headers and mounting bracket to PCB.

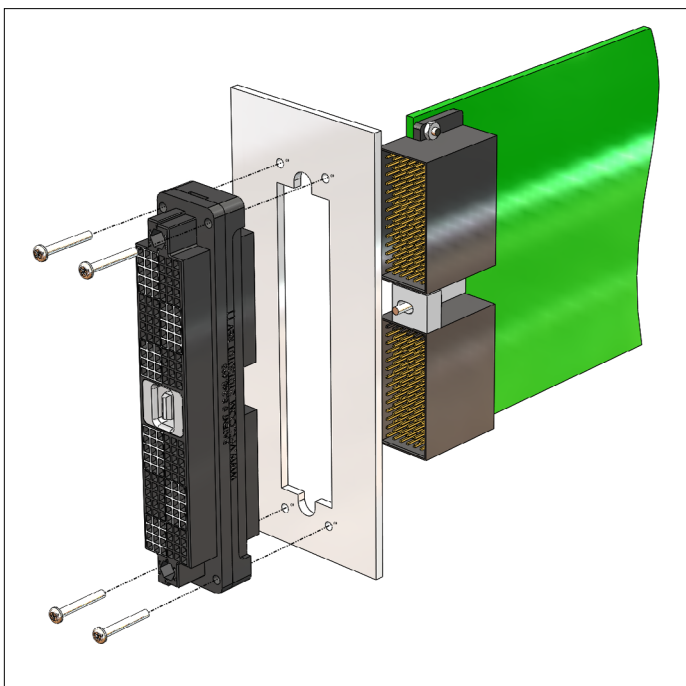

Figure B. Secure receiver to mounting panel.

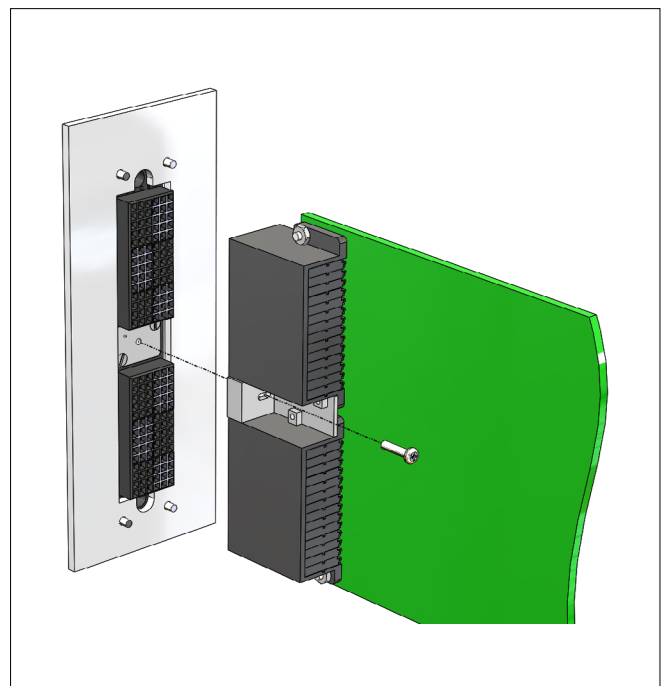
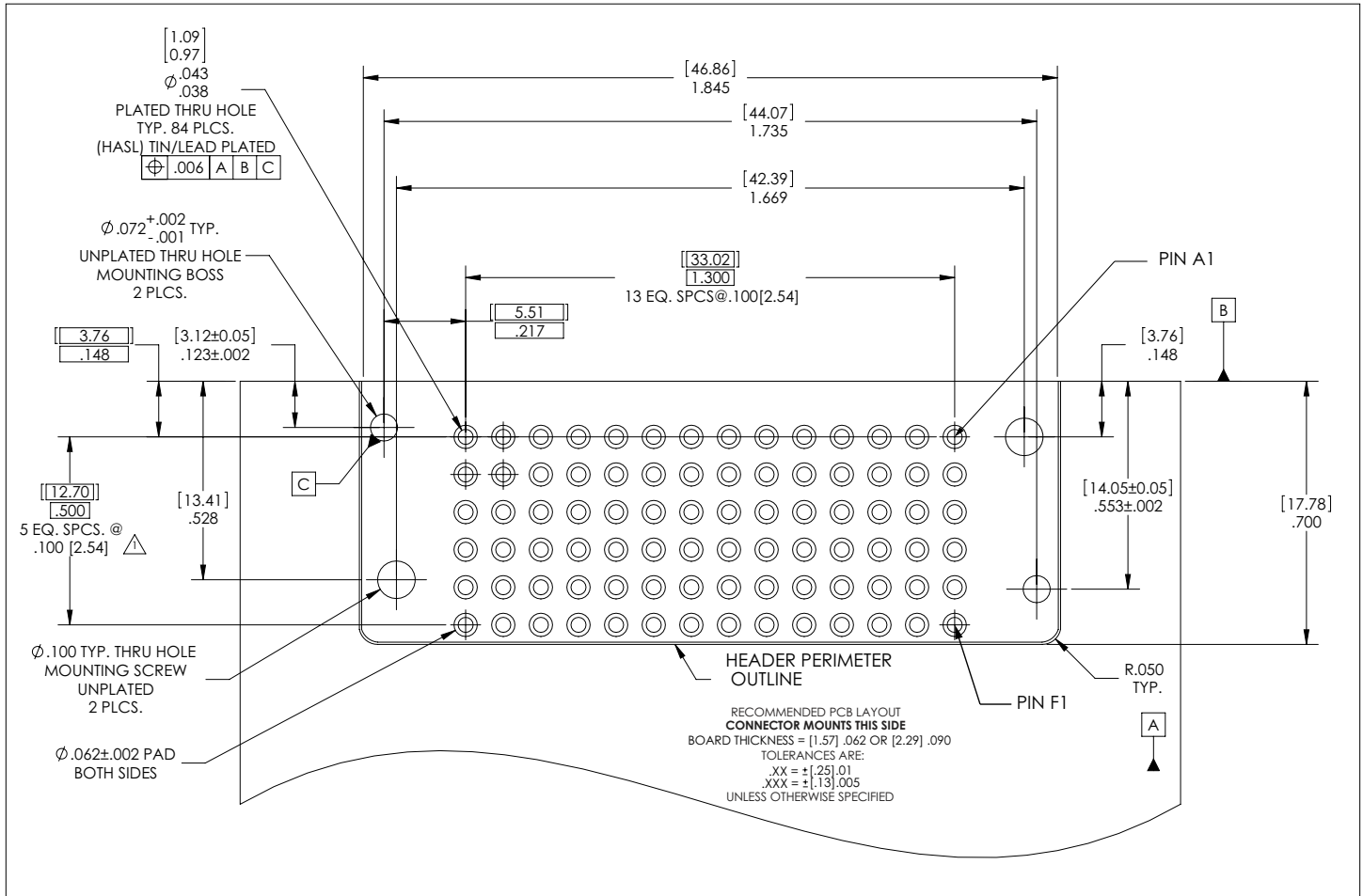

Figure C. Secure mounting bracket to receiver.

[RETURN TO INDEX](#)

PCB LAYOUT

HEADER, 84 POSITION RIGHT ANGLE WITH COMPLIANT PIN • PART # 510109204



(Figure A.) PCB layout. Connector mounts this side.
Board thickness = [1.57] .062 or [2.29] .090

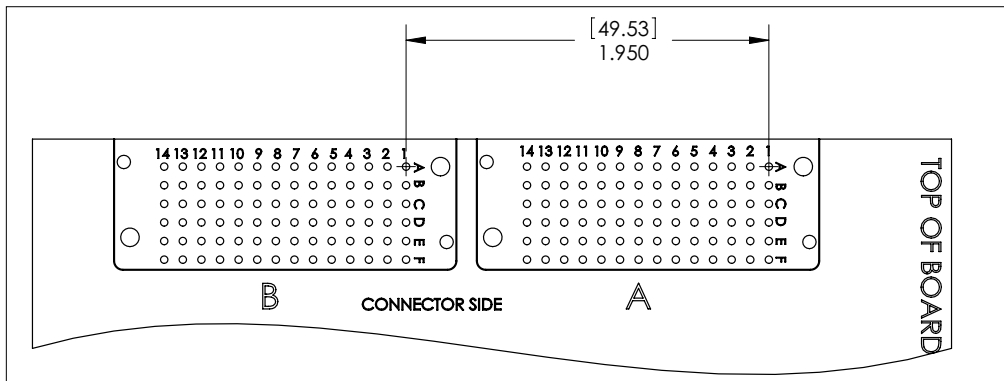

(Figure B.) Two header layout for 310130101 receiver.

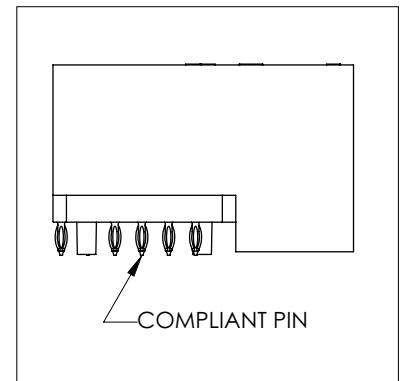

(Figure C.) Compliant header pin.

[RETURN TO INDEX](#)

STANDARD PCB LAYOUT

i2 RECEIVER • PART # 310130101

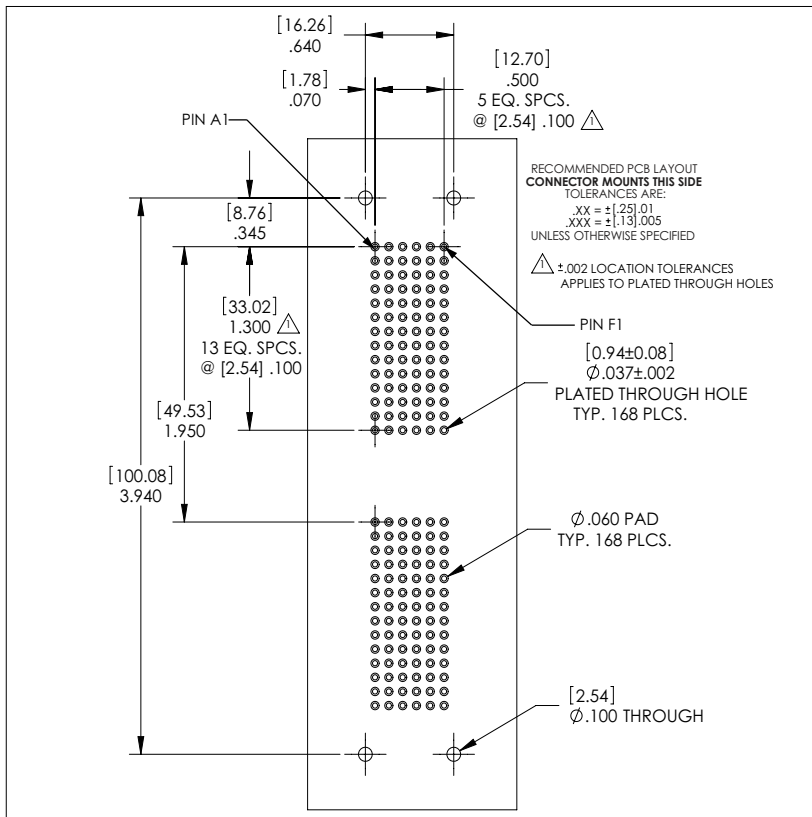

(Figure A) PCB layout for i2 receiver, Part # 310130101. Through hole and pad diameters are for VPC QuadraPaddle male Adapter Contact, Part # 610138117. The size of these holes may be different if a header from a different manufacturer is used. Connector mounts this side.

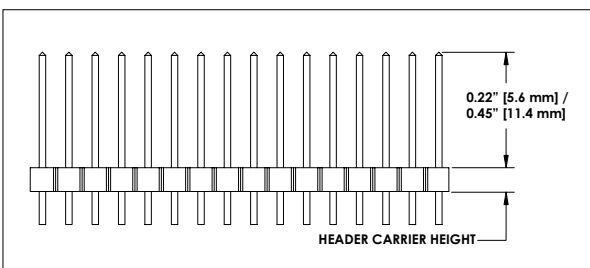

(Figure C). Twin male header.

NOTE: (Figure C) details 0.22" [5.59 mm]/0.45" [11.43 mm] min/ max engagement.
NOTE: Minimum spacer height = 0.24" + header carrier height - panel thickness (if used). Any additional height beyond this minimum must be added to the header post limits shown in **(Figure C)**.
NOTE: Several manufacturers offer the twin male header: Samtec, TE, MultiComp, Molex. The specific part number required is dependent on the distance the i2 will be located from the PCB, the thickness of the PCB, and the plating type required.

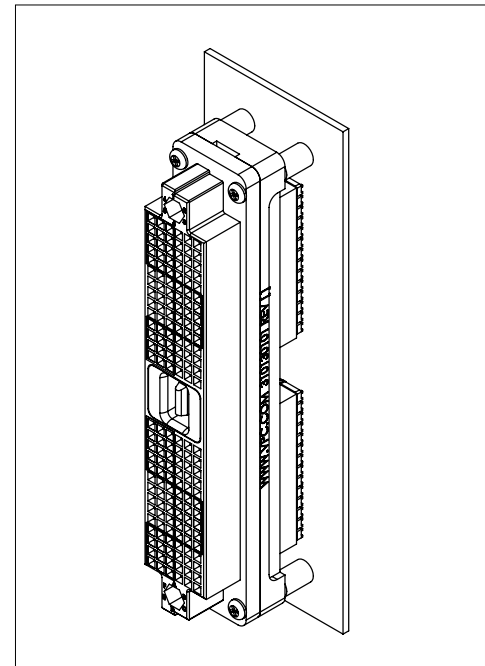

(Figure B) i2 receiver, Part # 310130101, loaded with twin female contacts, Part # 610138200. Twin male headers are used to connect the female contacts to the PCB plated through holes.

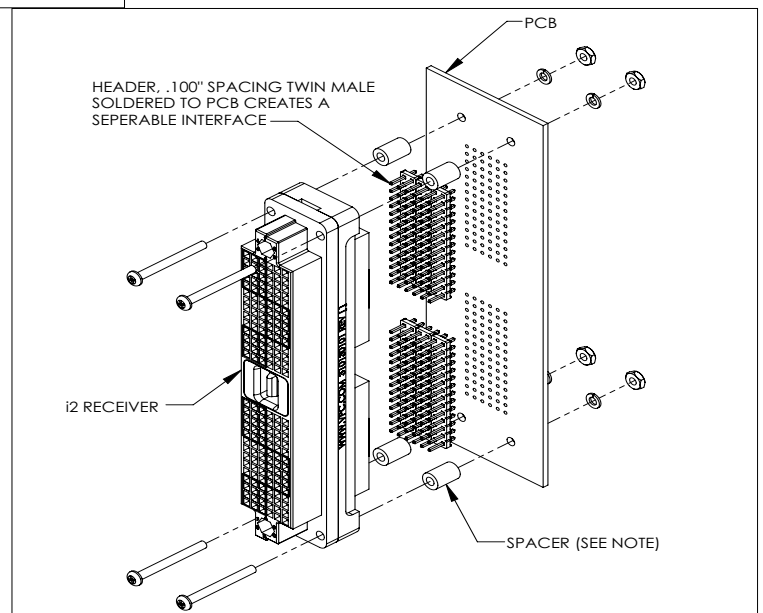

(Figure D) For Planar PCB applications similar to above, longer screws (qty 4) will be required than the .62" length screws that are supplied for wired panel mounting applications. These screws must be supplied by the customer and can be M2 or 2-56. If using M2, corresponding M2 nuts will need to be procured also. Screw length may vary depending on PCB and insulator thickness, but a 1" [25mm] length is typically sufficient. Spacers are also recommended to prevent unwanted stress on the PCB assembly.

[RETURN TO INDEX](#)

HYBRID PCB LAYOUT

HEADER, 60 POSITION RIGHT ANGLE WITH COMPLIANT PIN • PART # 510109206

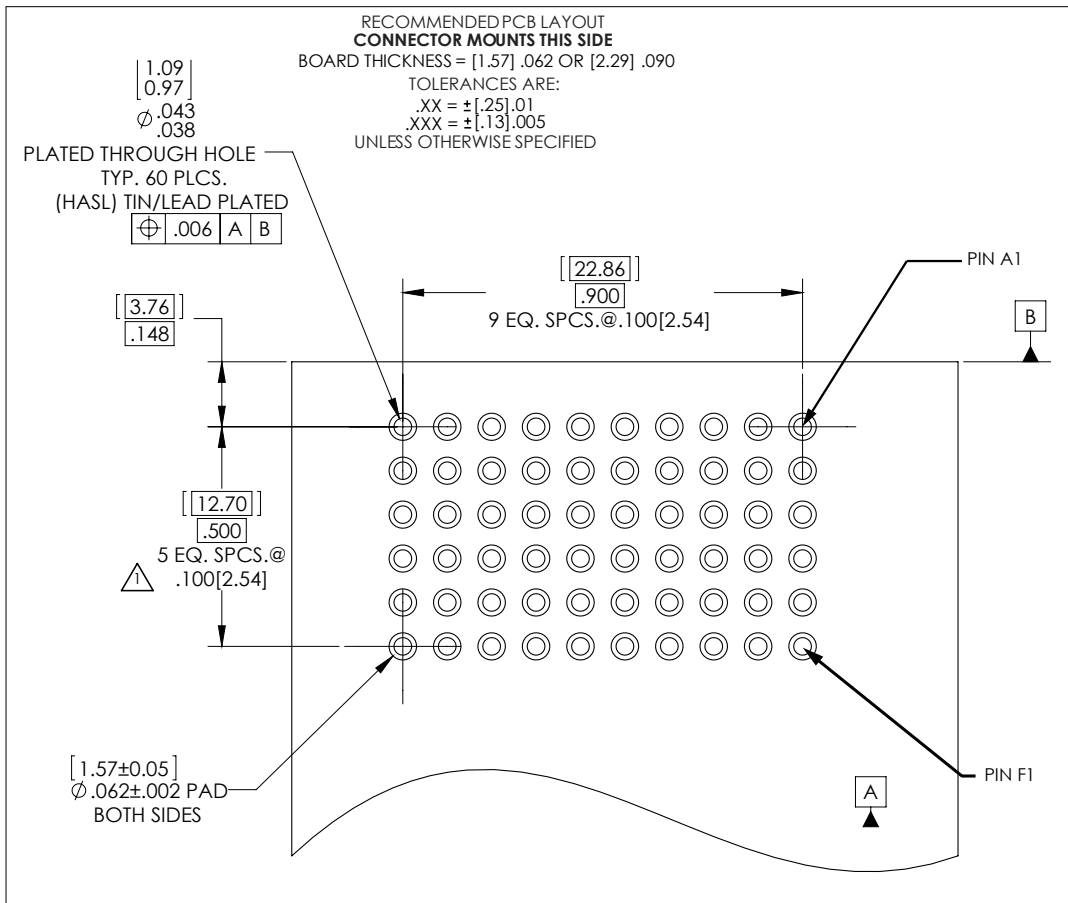

(Figure A) PCB layout. Connector mounts this side.
Board thickness = [1.57] .062 or [2.29] .090

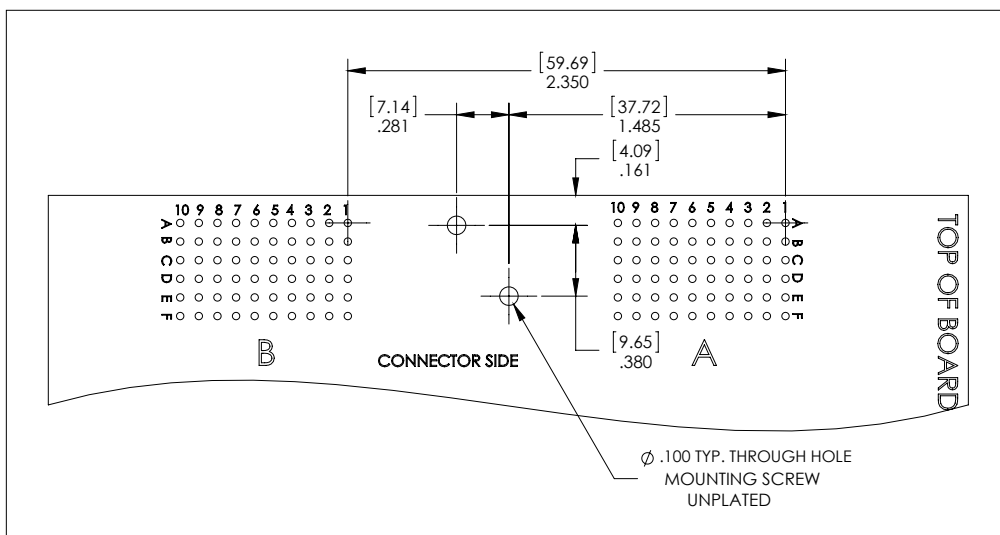

(Figure B) Two header layout for 310130104 receiver.

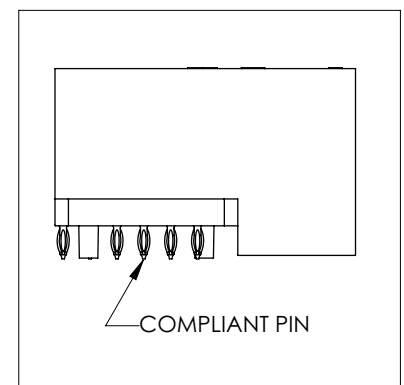

(Figure C) Compliant header pin.

[RETURN TO INDEX](#)

TROUBLESHOOTING

ITA frame is not lined up when engaging with the receiver.

This may indicate that the ITA was dropped and is out of alignment or that a module is not mating with its intended module.

- Remove and inspect the ITA for alignment.
- Check for foreign objects/tools.
- Inspect the matching of modules - signal ITA module mating with signal receiver module, etc.
- The keying pin locations mate.
- Make sure engagement knob is installed incorrectly.



Forceful engagement when attempting to mate the receiver and the ITA will result in serious damage to multiple parts of the system (modules, receiver, ITA and contacts)

[RETURN TO INDEX](#)