



i2 MX USER MANUAL

INDEX ([CLICK TO NAVIGATE TO PAGE](#))

PAGE

- 2** [RECEIVER PART DIAGRAM](#)
- 3** [ITA PART DIAGRAM](#)
- 4** [RECEIVER & ITA ENGAGEMENT & DISENGAGEMENT](#)
- 5** [RECEIVER MOUNTING](#)
- 6** [ITA BACKSHELL REMOVAL](#)
- 8** [ITA CABLE ASSEMBLY & BACKSHELL INSTALLATION](#)
- 11** [CONTACT REMOVAL](#)
- 12** [MODULE INSERT INSTALLATION & REMOVAL](#)
- 13** [VTAC RAIL INSTALLATION & REMOVAL](#)
- 14** [RECEIVER STRAIN RELIEF ASSEMBLY](#)
- 15** [PROTECTIVE COVER USE](#)
- 16** [KEYING PIN KIT ITA & RECEIVER INSTALLATION](#)
- 17** [STANDARD PCB LAYOUTS](#)
- 20** [RIGHT ANGLE VTAC PCB LAYOUT](#)
- 21** [TROUBLESHOOTING](#)

Please note that any printed or downloaded User Manuals may not reflect the most current revisions. The information contained in these materials is subject to change. For the most current information available, visit vpc.com.

RECEIVER PART IDENTIFICATION

PART # 310130113, 310130114, 310130202, 310130203, 310130204, 310130205, 310130206, 310130212

Figure B points out distinguishing features of the i2 MX receiver so that the top and bottom can be identified. Features to look for are the numeric keying receptacle at the top and the alpha keying receptacle on the bottom.

When holding the i2 MX receiver, the top can be determined when the letters and numbers are oriented as shown in **Figure B**. The top position is designated by a black marking around the upper slot in Tier A and Tier B module locations (**Figure B**).

The front and rear of the i2 MX receiver are shown in **Figure C**. The front has a polarizing feature which prevents the ITA and receiver from being engaged in the incorrect orientation. The front of the i2 MX receiver can be identified as the side with the latching feature (**Figure A**).

Figure D shows the rear silkscreen that aides in indicating positions.

The front side mates with the i2 MX ITA. Wires exit the i2 MX receiver from the rear side.

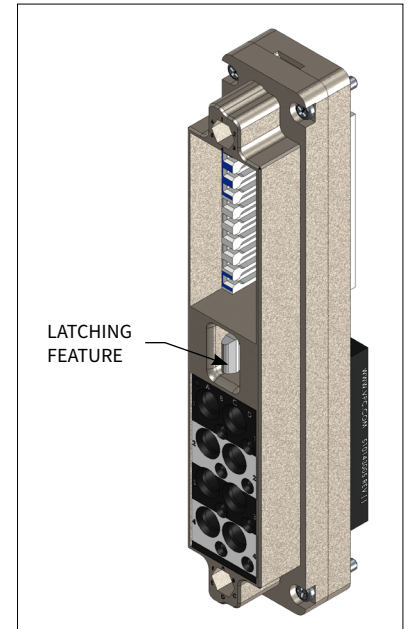

Figure A. i2 MX receiver.

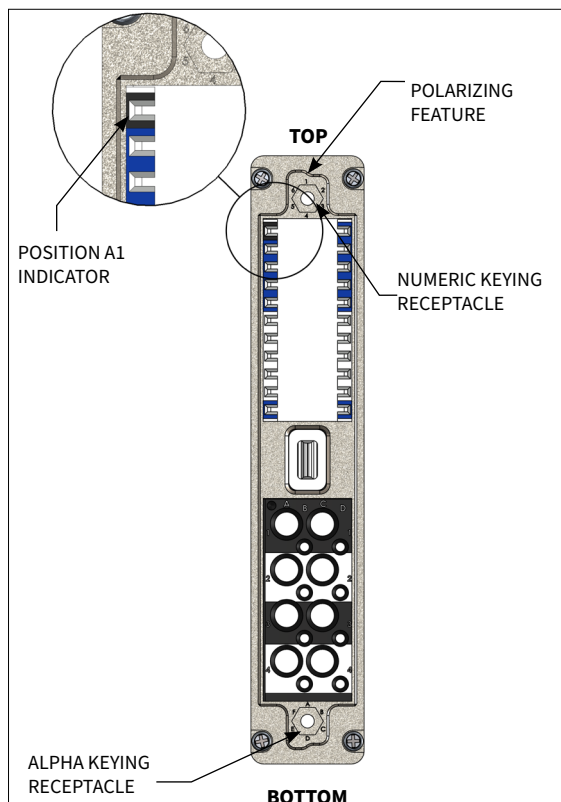

Figure B. i2 MX receiver front view.

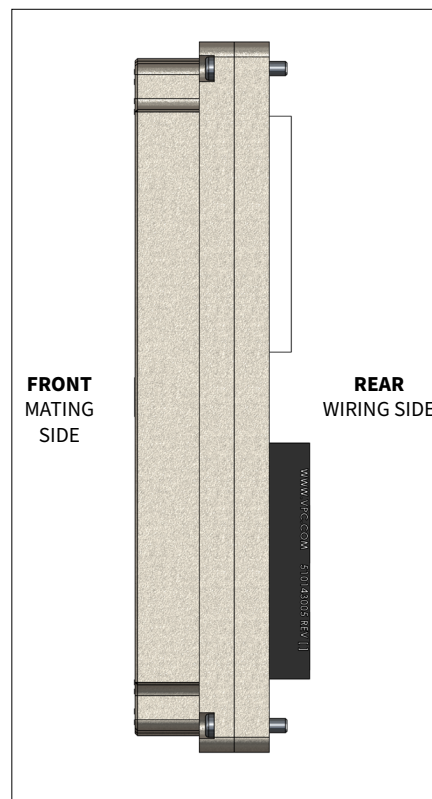

Figure C. i2 MX receiver side view.

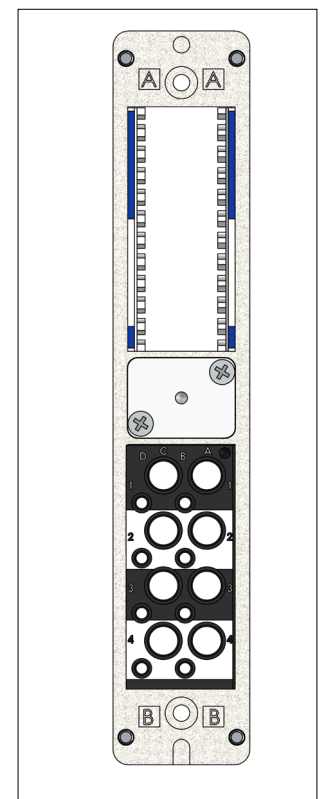

Figure D. i2 MX receiver rear view.

[RETURN TO INDEX](#)

ITA PART IDENTIFICATION

PART # 410130116, 410130202, 410130203, 410130204, 410130205, 410130206

Figure B points out distinguishing features of the i2 MX ITA so that the top and bottom can be identified. Features to look for are the numeric keying receptacle at the top and the alpha keying receptacle on the bottom.

When holding the i2 MX ITA, the top can be determined when the letters and numbers are readable. The top position is designated by a black marking around the upper slot in Tier A and Tier B module locations (**Figure B**).

The front and rear of the i2 MX ITA are easily distinguished as shown in **Figure C**. The front has a protruding guide plate with locking tabs (**Figure A**) and the rear has the knob.

Figure D shows the rear silkscreen that aides in indicating positions.

The front side mates with the i2 MX receiver. The front has a polarizing feature which prevents the ITA and receiver from being engaged in the incorrect orientation. Wires exit the i2 MX ITA through the 30° cable exit (**Figure C**).

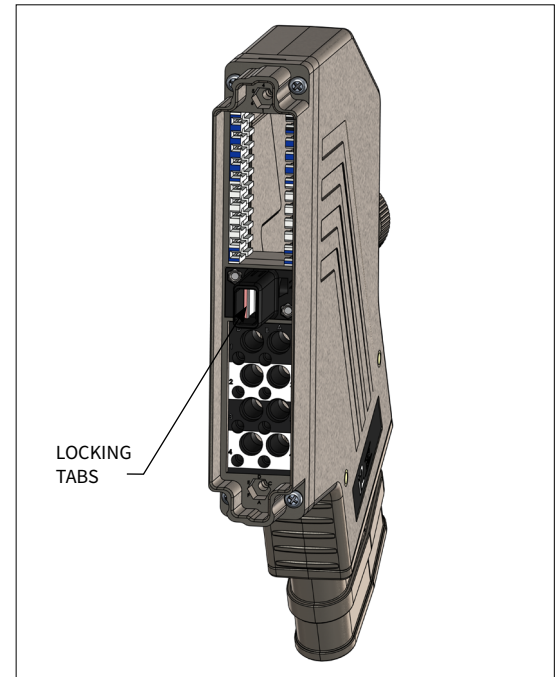

Figure A. i2 MX ITA.

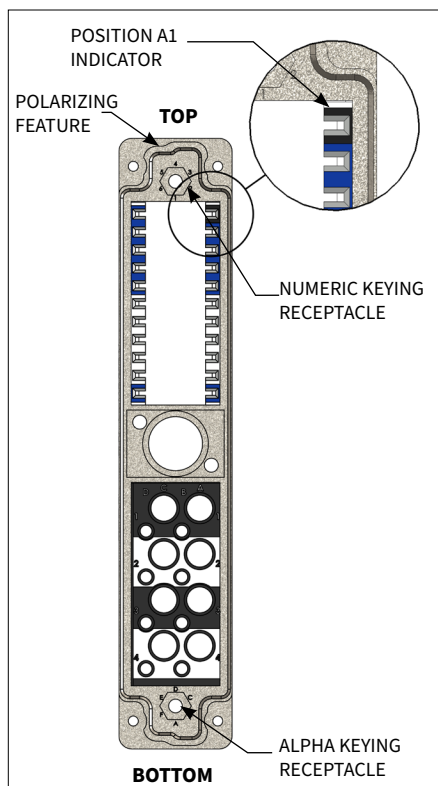

Figure B. i2 MX ITA front view.

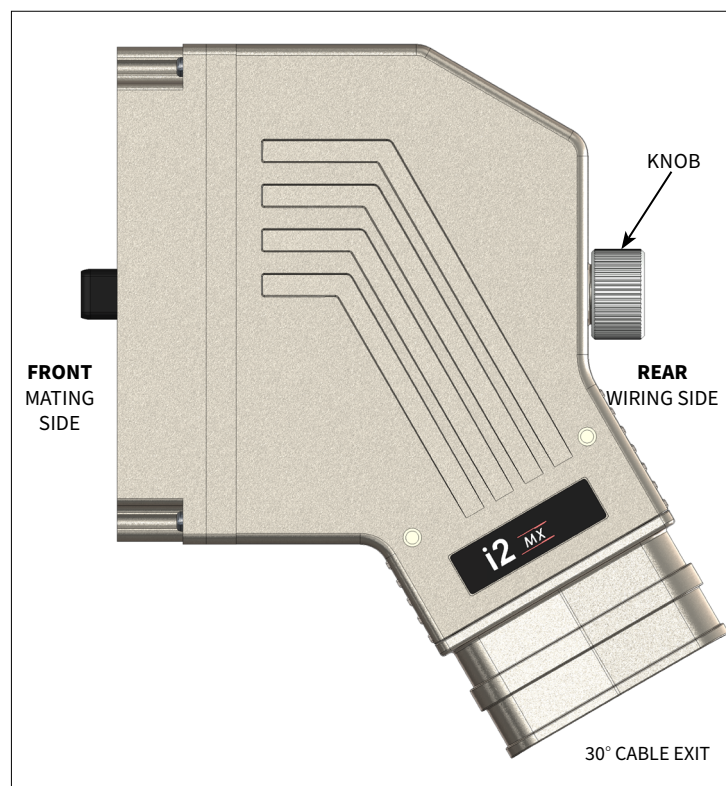

Figure C. i2 MX ITA side view.

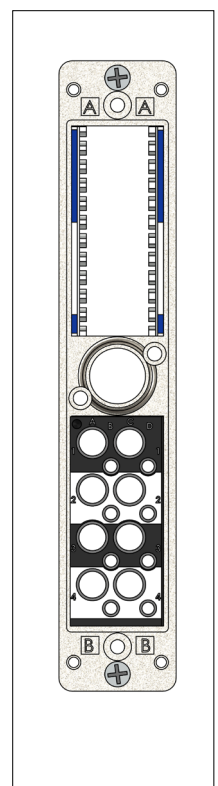

Figure D. i2 MX ITA rear view.

[RETURN TO INDEX](#)

RECEIVER AND ITA ENGAGEMENT/ DISENGAGEMENT

PART # 310130113, 310130114, 310130202, 310130203, 310130204, 310130205, 310130206, 310130212
410130116, 410130202, 410130203, 410130204, 410130205, 410130206

ENGAGEMENT

1. Rotate the knob counter-clockwise to the open, disengaged position.
2. Align the ITA with the receiver and push the ITA onto the receiver. There will be about a 0.25" [6.35 mm] gap (**Figure A**).

NOTE: The i2 MX connector is polarized; the ITA will not align if it is upside down.

NOTE: The i2 MX ITA can be left in this position without engaging the system.

3. Rotate the knob clockwise to engage (**Figure B**).

NOTE: For optimum performance and system longevity, distribute the contact load evenly. Two-hand support during engagement is recommended.

DISENGAGEMENT

1. Turn the engagement knob counter-clockwise to the open, disengaged position (**Figure A**).
2. Pull ITA straight back and remove.

NOTE: For unbalanced load, add force to the lower pin load during disengagement to prevent binding.

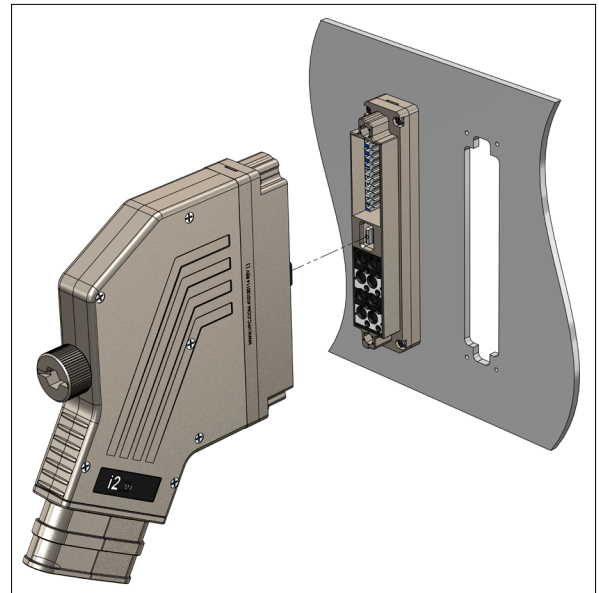

Figure A. Disengaged i2 MX ITA and receiver.

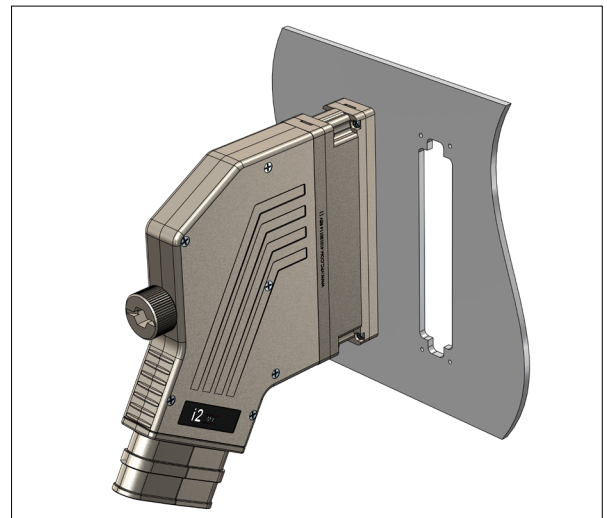

Figure B. Engaged i2 MX ITA and receiver.

RECEIVER MOUNTING

PART # 310130113, 310130114, 310130202, 310130203, 310130204, 310130205, 310130206, 310130212

TOOLS REQUIRED

Phillips Head Screwdriver

MOUNTING INSTRUCTIONS

1. Prepare the mounting surface using the dimensions provided in **Figure A**.
2. Attach the i2 MX receiver to the panel with the provided 2-56 Phillips head captive screws (**Figure B**). Torque screws to 3.5 in-lbs [0.4 Nm] into Aluminum and 2.5 in-lbs [0.28 Nm] into Steel.

NOTE: The dimensions shown reflect using a laser cutting or punch press process. If using conventional machining processes the 3.49" [88.65 mm] dimension will be 3.69" [93.73 mm] and a .09" [2.29 mm] radius needs to be added to the corners.

MATING ITA PART NUMBER	DESCRIPTION	RECOMMENDED RECEIVER CUTOUT SPACING Ø in. [mm]	MINIMUM RECEIVER CUTOUT SPACING Ø in. [mm]
410130114	ITA, i2 MX, EMI MODULAR	1.75 [44.45]	1.00 [25.40]
410130116	ITA, i2 MX, HSD EMI	1.75 [44.45]	1.00 [25.40]
410130117	ITA, i2 MX, MODULAR	1.75 [44.45]	1.00 [25.40]
410130121	ITA, i2 MX, ENH EMI MODULAR	1.75 [44.45]	1.00 [25.40]
410130122	ITA, i2 MX, ENH EMI MODULAR W/O CBL EXIT	1.75 [44.45]	1.00 [25.40]
410130126	ITA, i2 MX, XL EMI MODULATOR	1.75 [44.45]	1.75 [44.45]
410130132	ITA, i2 MX, XL EMI 16 MINI CX, 16 TRIPDL	1.75 [44.45]	1.75 [44.45]
410130133	ITA, i2 MX, XL HSD EMI	1.75 [44.45]	1.75 [44.45]
410130134	ITA, i2 MX, HSD, W/ STRN RLF	1.75 [44.45]	1.00 [25.40]
410130202	ITA, i2 MX, EMI 168 PN	1.75 [44.45]	1.00 [25.40]
410130203	ITA, i2 MX, EMI 18 MICRO CX, 16 TRIPDL	1.75 [44.45]	1.00 [25.40]
410130204	ITA, i2 MX, EMI 18 MICRO CX, 18 TRIPDL	1.75 [44.45]	1.00 [25.40]
410130205	ITA, i2 MX, EMI 84 QP, 9 MX, 9 TRIPDL	1.75 [44.45]	1.00 [25.40]
410130206	ITA, i2 MX, EMI 84 QP, HSD	1.75 [44.45]	1.00 [25.40]
410130212	ITA, i2 MX, ENH EMI 168 PN	1.75 [44.45]	1.00 [25.40]
410130220	ITA, i2 MX, XL EMI 168 PN	1.75 [44.45]	1.75 [44.45]

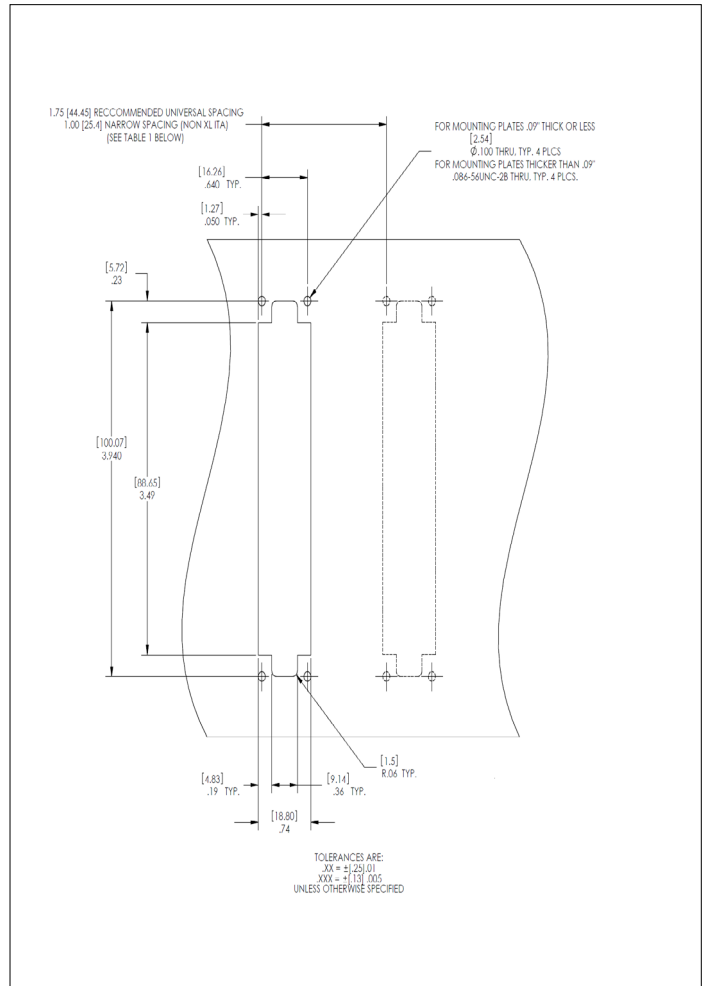

Figure A. Recommended panel cutout.

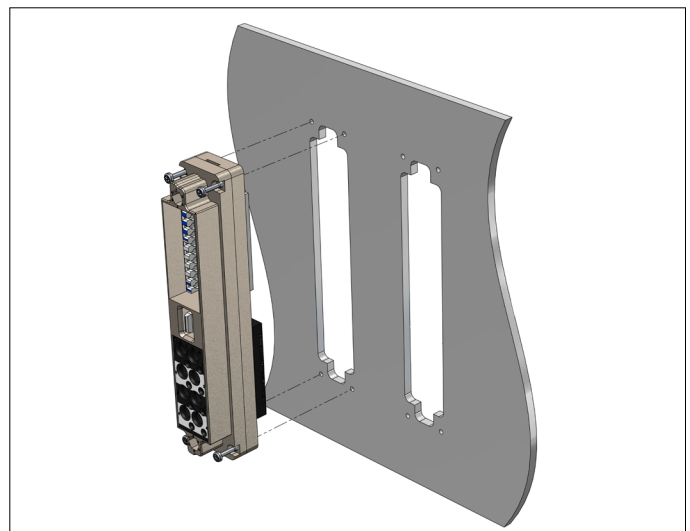

Figure B. Using the provided 2-56 Phillips head captive screws, attach the i2 MX receiver to the panel.

[RETURN TO INDEX](#)

ITA BACKSHELL REMOVAL

PART # 410130116, 410130202, 410130203, 410130204, 410130205, 410130206

TOOLS REQUIRED

Phillips Head Screwdriver
Flat Head Screwdriver
1/4" Nut Driver, hollow shaft

COVER REMOVAL INSTRUCTIONS

1. Disengage the ITA from the receiver.
2. Using a flat head screwdriver, remove the engagement knob screw and engagement knob (**Figure A**).
3. Using a Phillips head screwdriver, loosen the four screws (captive) that secure the backshell to the ITA frame (**Figure B**).

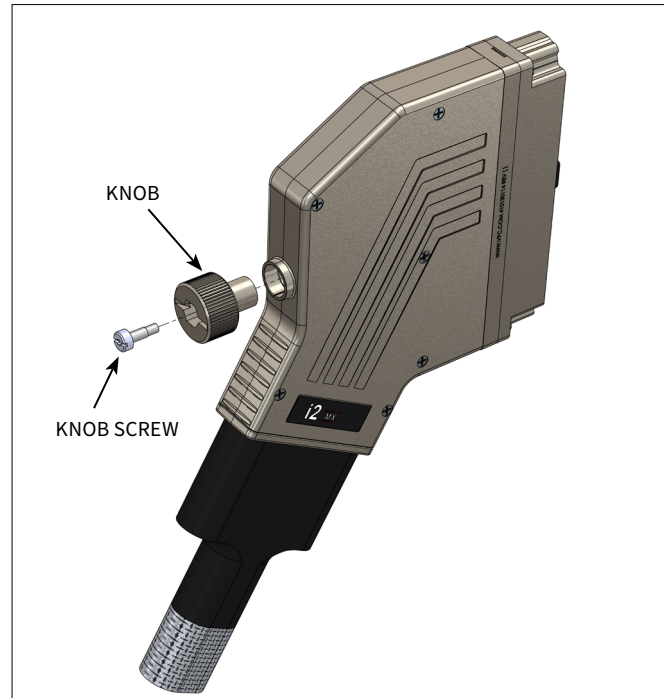

Figure A. i2 MX knob removal.

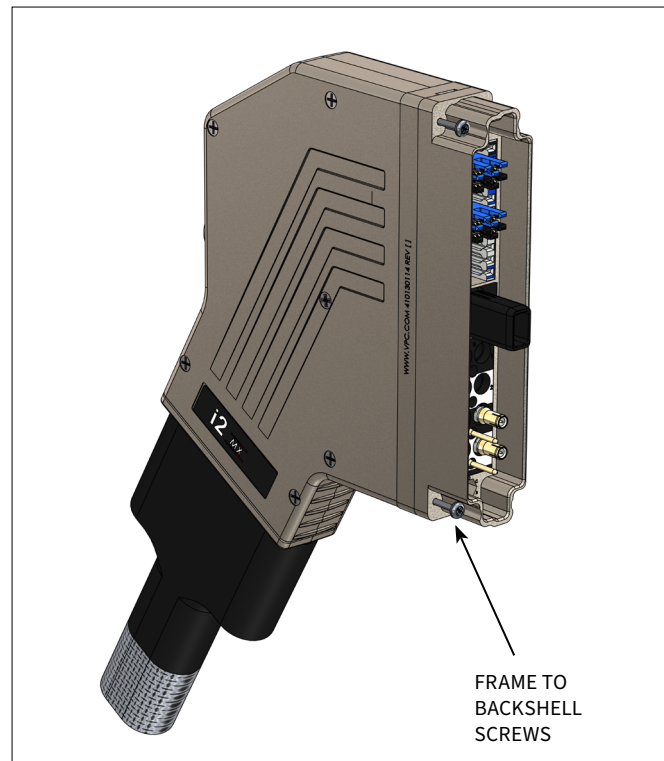

Figure B. i2 MX backshell screws removal.

[RETURN TO INDEX](#)

ITA BACKSHELL REMOVAL (CONT'D)

PART # 410130116, 410130202, 410130203, 410130204, 410130205, 410130206

- Using a Phillips head screwdriver, loosen the six screws (captive) that secure the backshell halves. Remove the half with the screws (**Figure C**).
- Using a nut driver, remove nuts on the strain relief clamp, then remove the clamp (**Figure D**).

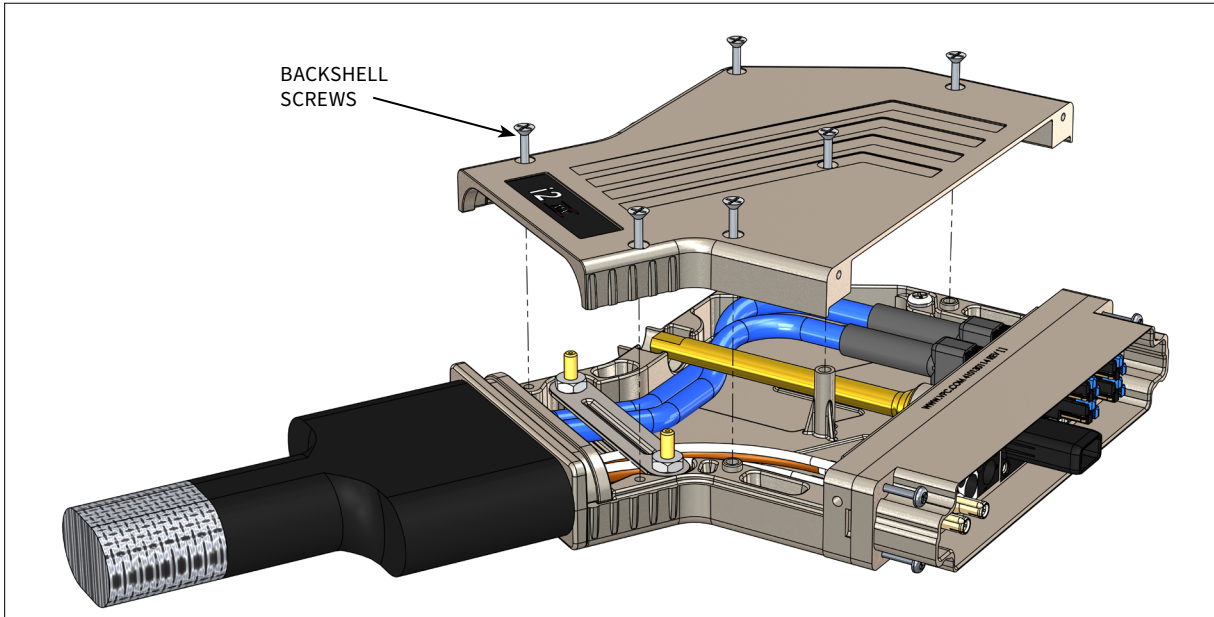

Figure C. i2 MX backshell cover removal.

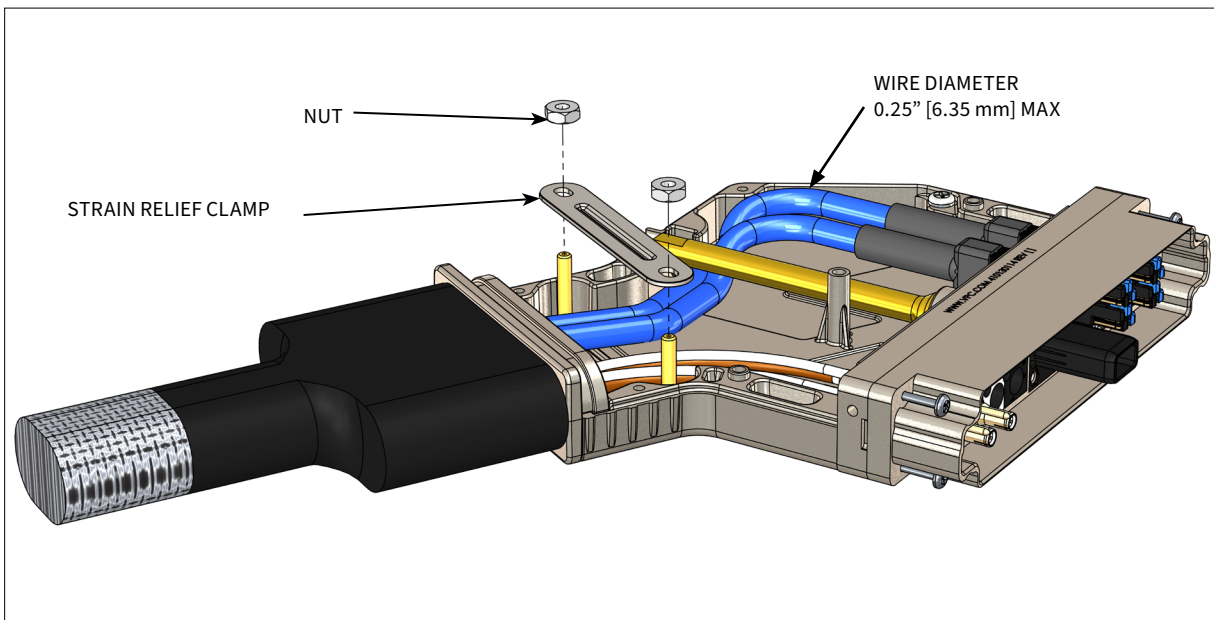

Figure D. i2 MX strain relief clamp removal.

[RETURN TO INDEX](#)

ITA CABLE ASSEMBLY AND BACKSHELL INSTALLATION

PART # 410130116, 410130202, 410130203, 410130204, 410130205, 410130206

TOOLS REQUIRED

- Phillips Head Screwdriver
- 1/4" Nut Driver, hollow shaft
- Banding Tool, Part # 910 121 202
- 1/8" band(s)
- Dull Needle
- Wax Lacing Tape
- Silicone Tape
- Sleeving
- Scissors

INSTALLATION INSTRUCTIONS

1. Plug Patchcords/contacts into module (**Figure A**).
2. Assemble first half of backshell on ITA frame by securing captive screws through bottom of frame into backshell (**Figure B**). Torque screws to 2 in-lbs [0.23 Nm].
3. If necessary, locate the internal ground screw positioned inside the backshell (**Figure C**).

FORMULA TO CALCULATE THE MAXIMUM NUMBER OF WIRES IN A CABLE BUNDLE

$$B = 1.2 \sqrt{(N_1 d_1^2 + N_2 d_2^2 + \dots + N_n d_n^2)}$$

B = Wire Bundle Diameter	N ₁ = Quantity of first wire type	d ₁ = Outside Diameter of first wire type
	N ₂ = Quantity of second wire type	d ₂ = Outside Diameter of second wire type
	N _n = Quantity of n th wire type	d _n = Outside Diameter of n th wire type

WIRE TYPE	Ø in. [mm]	# WIRES	MAX BUNDLE Ø in. [mm]
26AWG 16878/4	0.043 [1.09 mm]	375	1.0 [25.4 mm]
24AWG 16878/4	0.048 [1.22 mm]	301	1.0 [25.4 mm]
22AWG 16878/4	0.054 [1.37 mm]	238	1.0 [25.4 mm]
M27500-26ml2t08	0.114 [2.90 mm]	53	1.0 [25.4 mm]
M27500-24ml2t08	0.126 [3.20 mm]	43	1.0 [25.4 mm]
M27500-22ml2t08	0.140 [3.56 mm]	35	1.0 [25.4 mm]
M27500-22ml1t08	0.087 [2.21 mm]	91	1.0 [25.4 mm]
22AWG 16878/4 T/P	0.108 [2.74 mm]	59	1.0 [25.4 mm]
24AWG 16878/4 T/P	0.096 [2.44 mm]	75	1.0 [25.4 mm]

NOTE: Acceptable bundle dimension must be reduced when using sleeving and shrink tubing.
 NOTE: Wire diameter should be less than 0.25" [6.35 mm].

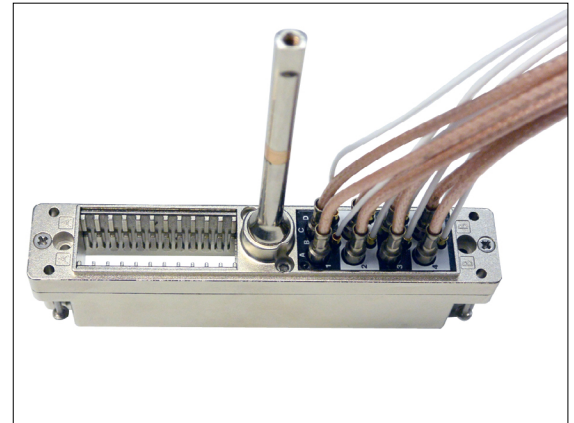

Figure A. Plug patchcords.

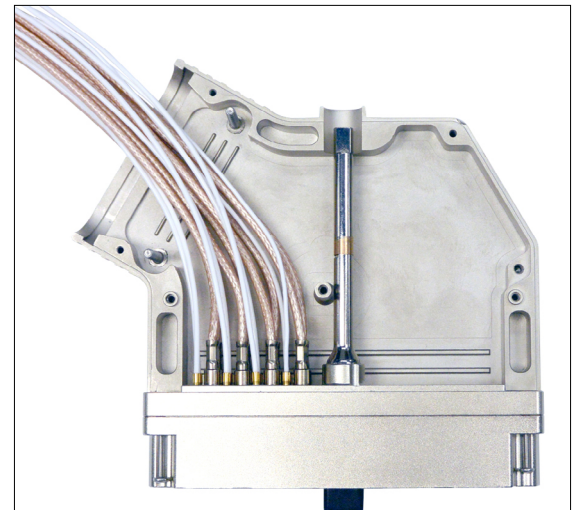

Figure B. Assemble first half of backshell.

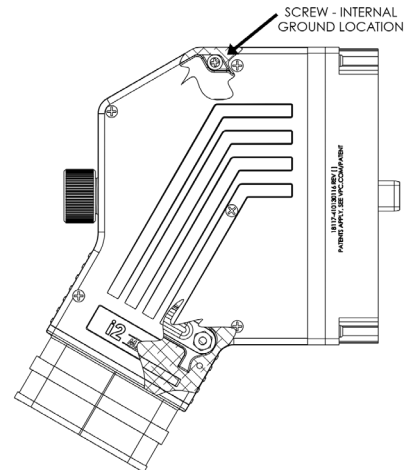

Figure C. Note the location of the Internal Ground Screw.

[RETURN TO INDEX](#)

ITA CABLE ASSEMBLY AND BACKSHELL INSTALLATION (CONT'D)

PART # 410130116, 410130202, 410130203, 410130204, 410130205, 410130206

- Build up cable bundle diameter with silicone tape as necessary. Capture cable exit in grooves of backshell (**Figure C, D, Section 5-1**). Flex wire bundle forward to create small service loop. Secure bundle by tightening strain relief clamp (**Figure C**).

CAUTION

Over tightening the strain relief clamp can damage the wire. Tighten only enough to secure the cable bundle, 5 in-lbs [0.56 Nm] is the maximum amount of torque that should be applied to the strain relief nuts.

- Place other half of backshell on ITA frame and secure with remaining two (2) pan head captive screws. Secure the six (6) flat head captive screws that hold the backshell together. Torque screws to 2 in-lbs [0.23 Nm]. Add engagement handle and screw (**Figure E**).

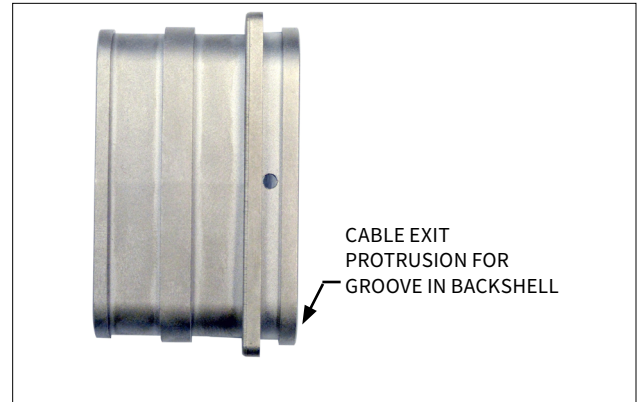

Figure D. Cable exit protrusion.

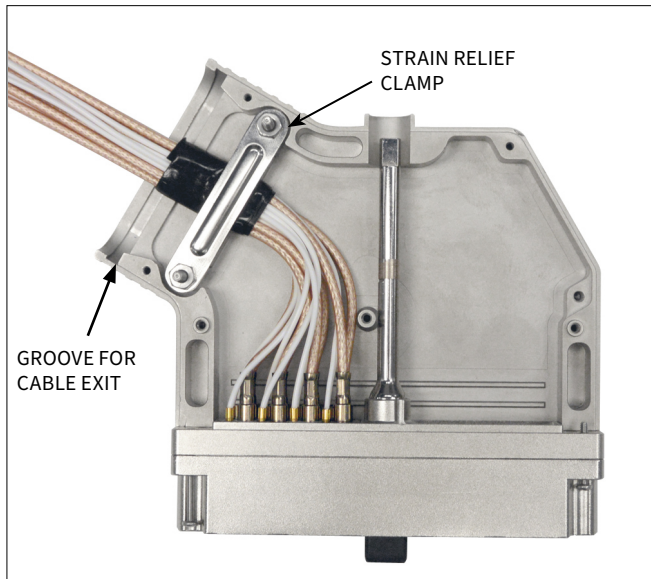

Figure C. Silicone tape and secure.

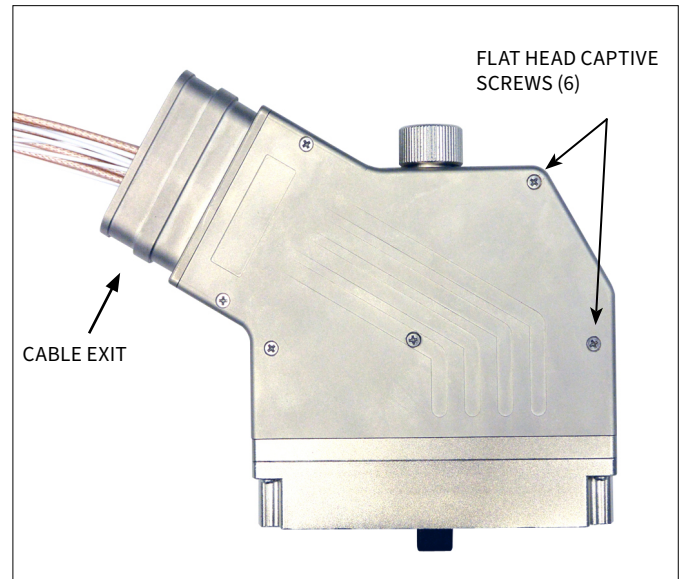

Figure E. Install Second half of backshell.

[RETURN TO INDEX](#)

ITA CABLE ASSEMBLY AND BACKSHELL INSTALLATION (CONT'D)

PART # 410130116, 410130202, 410130203, 410130204, 410130205, 410130206, 910121202

NOTE: ITA Cable Assembly build up should be no more than 0.800" width for mounting on 0.800" centers.

- Slide the metal EMI braid up to first lip of cable clamp area and secure the band with Banding Tool. Trim the metal braid back even with lip if necessary. **(Figure F & G).**

NOTE: For detailed instructions of Banding Tool use, refer to the Banding Tool, Part # 910121202, Procedure Sheet.

- Secure loose end of metal EMI braid with fiberglass tape to keep EMI braid from protruding through heat shrink tubing **(Figure H).**
- Slide sleeving up to wire exit end of cable clamp and secure with several passes of lacing tape woven through sleeving and metal braid. Slide heat shrink tubing up to front flange of cable clamp and shrink in place **(Figure I & J).**

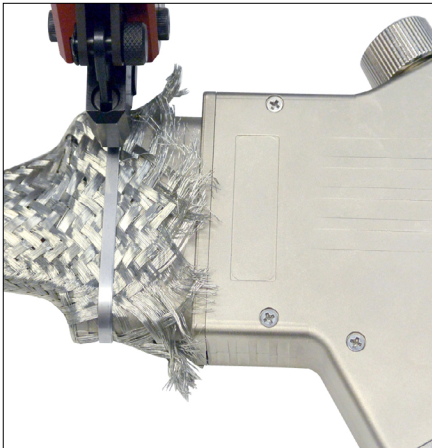

Figure F. EMI braid.

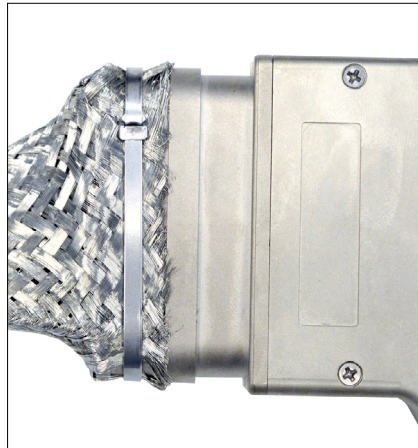

Figure G. EMI braid with band.

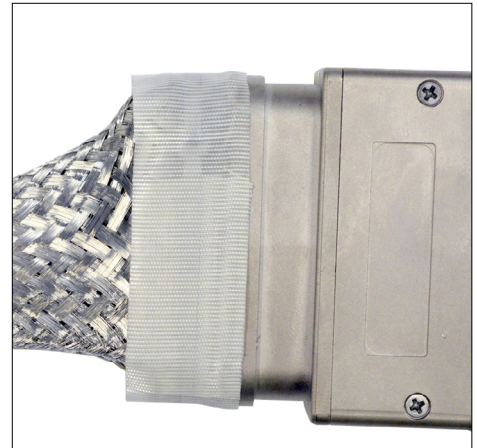

Figure H. Fiberglass tape.

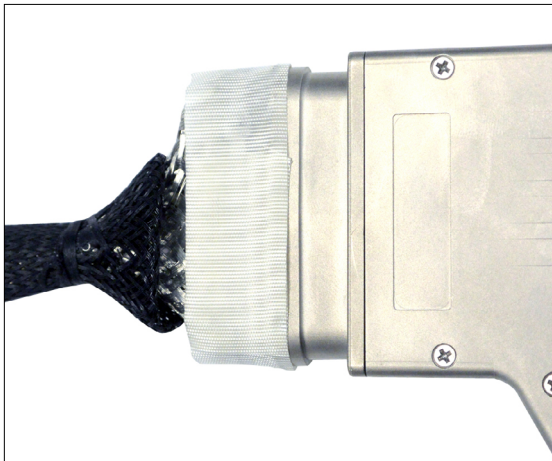

Figure I. Sleeving.

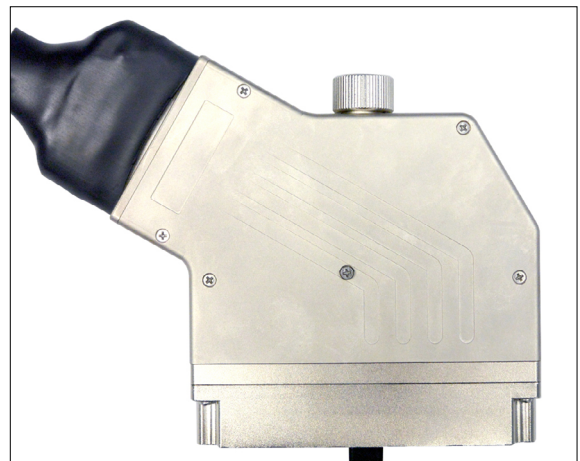

Figure J. Shrink tubing.

[RETURN TO INDEX](#)

CONTACT REMOVAL

PART # 310130XXX / 410130XXX / 610103XXX / 610104XXX / 610110101 / 610110108 / 610115124 / 610116112 / 610138109 / 610138112 / 610138200 / 610138216 / 610 140XXX / 610141XXX / 610142101 / 610143101

TOOLS REQUIRED

Phillips Head Screwdriver

RECEIVER INSTRUCTIONS

1. Remove strain relief or keying pins, if needed. See [page 16](#) for more information.
2. If mounted to a panel, using a Phillips head screwdriver, remove receiver from panel (**Figure A**).

NOTE: For VTAC patchcords skip steps 3, 4 and 5. Extract VTAC patchcords per the VTAC User Manual.

3. Using the Phillips head screwdriver, remove the two flat head assembly screws from the back of the receiver (**Figure A**).
4. Separate receiver frame halves.
5. Separate module insert halves.

NOTE: Install/Extract QuadraPaddle contacts per the QuadraPaddle User Manual. Reference contact Part # 610138200 or contact Part # 610138216. Install/Extract TriPaddle contacts, per TriPaddle User Manual. Reference contact Part # 610110101.

NOTE: Install/Extract Micro Power contacts per the Micro Power User Manual. Reference contact Part # 610142101. Install/Extract Micro Coaxial contacts per the Micro Coaxial User Manual. Reference contact Part # 610140XXX (substitute last 3-digits based on Micro Coaxial/Power contact being used).

NOTE: Install/Extract Mini Power contacts per the Mini Power User Manual. Reference contact Part # 610116112. Install/Extract Mini Coaxial contacts per the Mini Coaxial User Manual. Reference contact Part # 610104XXX (substitute last 3-digits based on Mini-Coaxial/Power contact being used).

ITA INSTRUCTIONS

1. Refer to ITA cover removal instructions in this manual to remove the backshell.

NOTE: Install/Extract QuadraPaddle contacts per the QuadraPaddle User Manual. Reference contact Part # 610138109 or 610138112. Install/Extract TriPaddle contacts, per TriPaddle User Manual. Reference Part # 610110108.

NOTE: For extraction, use the Micro Power/Micro Coaxial extraction tool Part # 910112127. Install/Extract Micro Power contacts per the Micro Power User Manual. Reference contact Part # 610143101. Install/Extract Micro Coaxial contacts per the Micro Coaxial User Manual. Reference contact Part # 610141XXX (substitute last 3-digits based on Micro Coaxial contact being used).

NOTE: Install/Extract Mini Power contacts per the Mini Power User Manual. Reference contact Part # 610115124. Install/Extract Mini Coaxial contacts per the Mini Coaxial User Manual. Reference contact Part # 610103XXX (substitute last 3-digits based on Mini-Coaxial contact being used).

NOTE: Install/Extract VTAC Patchcords per the VTAC User Manual.

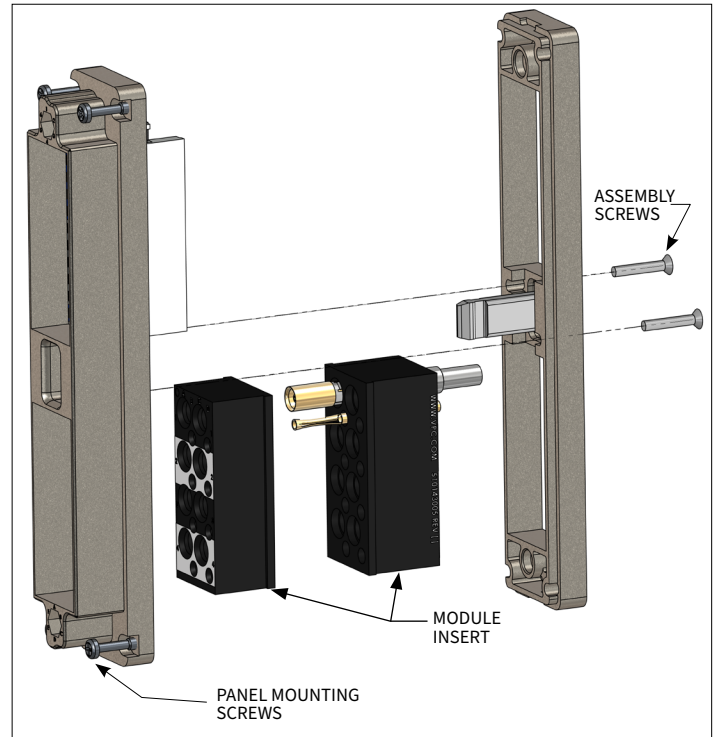

Figure A. i2 MX receiver separation.

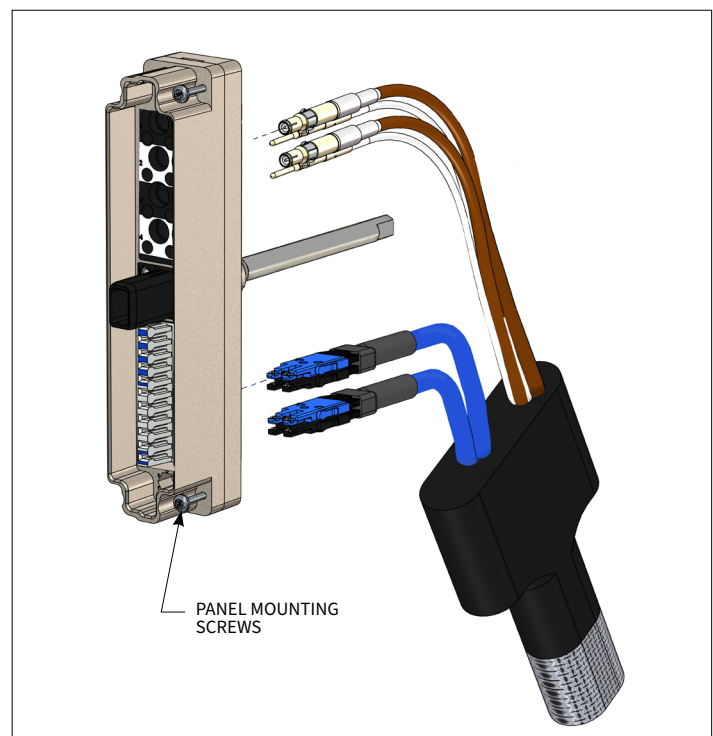

Figure B. i2 MX ITA contact extraction.

[RETURN TO INDEX](#)

MODULE INSERT INSTALLATION/REMOVAL

PART # 310130XXX AND 410130XXX

TOOLS REQUIRED

Phillips Head Screwdriver

i2 MX MODULE INSERT(S) REMOVAL INSTRUCTIONS

1. If working with a receiver, use a Phillips head screwdriver to remove strain relief by removing screws (**Figure A**).

The ITA will require removal of backshell first see **Section 4** of this User Manual.

2. Using a Phillips head screwdriver, remove the two Phillips flat head screws that are holding the frame halves together.

For ITA use a Phillips head screwdriver to loosen the two captive screws on the back of rear frame (**Figure B**).

3. Pull halves apart.
4. Remove module insert(s).

i2 MX MODULE INSERT(S) INSTALLATION INSTRUCTIONS

1. For installing module insert(s), orient insert(s) as shown in (**Figure A**) and (**Figure C**). Place insert(s) ledge on flat surface shown in (**Figure D**), then put halves together and tighten with flat head screws using a Phillips head screwdriver.

NOTE: Receiver/ITA frame halves are keyed to be placed together only one direction.

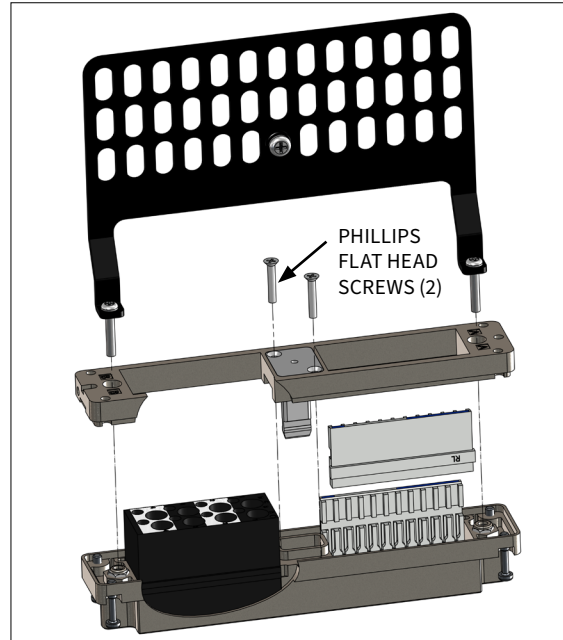

Figure A. Module insert install and removal (receiver shown).

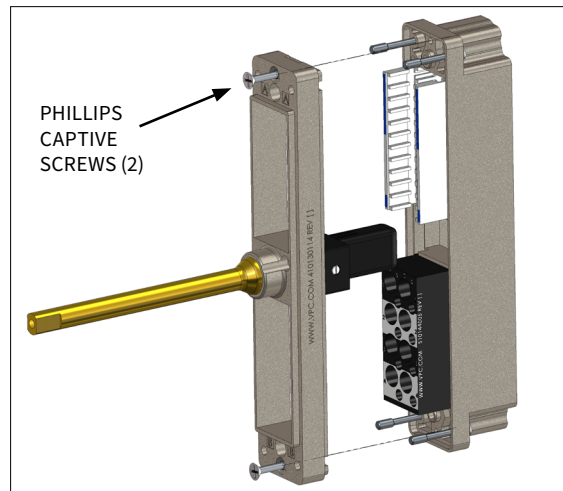

Figure B. ITA frame separation.

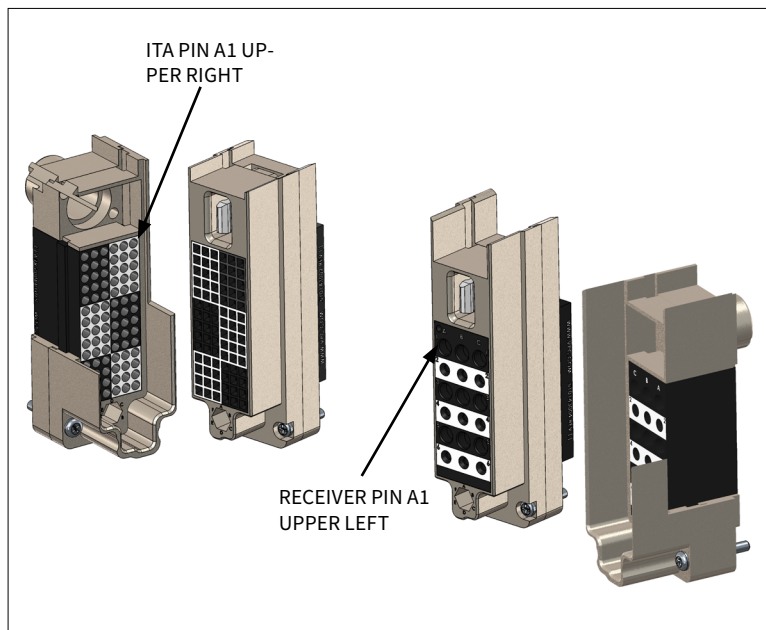

Figure C. Module insert install and removal (receiver shown).

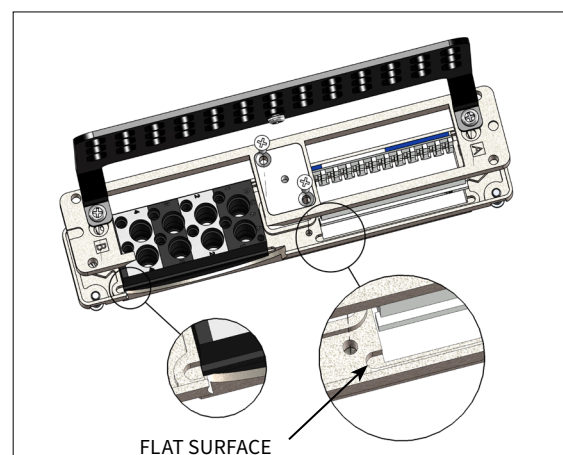

Figure D. Module insert install and removal (receiver shown).

[RETURN TO INDEX](#)

VTAC RAIL INSTALLATION/REMOVAL INSTRUCTIONS

PART # 310130XXX AND 410130XXX

TOOLS REQUIRED

Phillips Head Screwdriver

VTAC HSD RAIL(S) REMOVAL INSTRUCTIONS

1. If working with a receiver, use a Phillips head screwdriver to remove strain relief by removing screws (**Figure A**).

The ITA will require removal of backshell first. See **Section 2** of this User Manual for instructions.

2. After removing strain relief/backshell, use a Phillips head screwdriver to remove the two Phillips flat head screws that are holding the frame halves together (**Figure A**).

For ITA use Phillips head screwdriver to loosen the two captive screws on the back of the rear frame (**Figure B**).

3. Pull halves apart.
4. Remove VTAC HSD Rail(s).

VTAC HSD RAIL(S) INSTALLATION INSTRUCTIONS

1. To install VTAC HSD Rail(s), orient rail(s) as shown in (**Figure A**). **Figure C** illustrates the identifiers to aid in orientation (receiver rails shown). The receiver rails are marked with 'RR' (receiver right) and 'RL' (receiver left) when viewing from mating face. The ITA rails are marked with 'IR' (ITA right) and 'IL' (ITA left) when viewing from rear/wiring side.

2. Place rail(s) ledge on flat surface shown in (**Figure D**), then put halves together and tighten the two Phillips flat head screws using a Phillips head screwdriver.

NOTE: Receiver/ITA frame halves are keyed to be placed together only one direction.

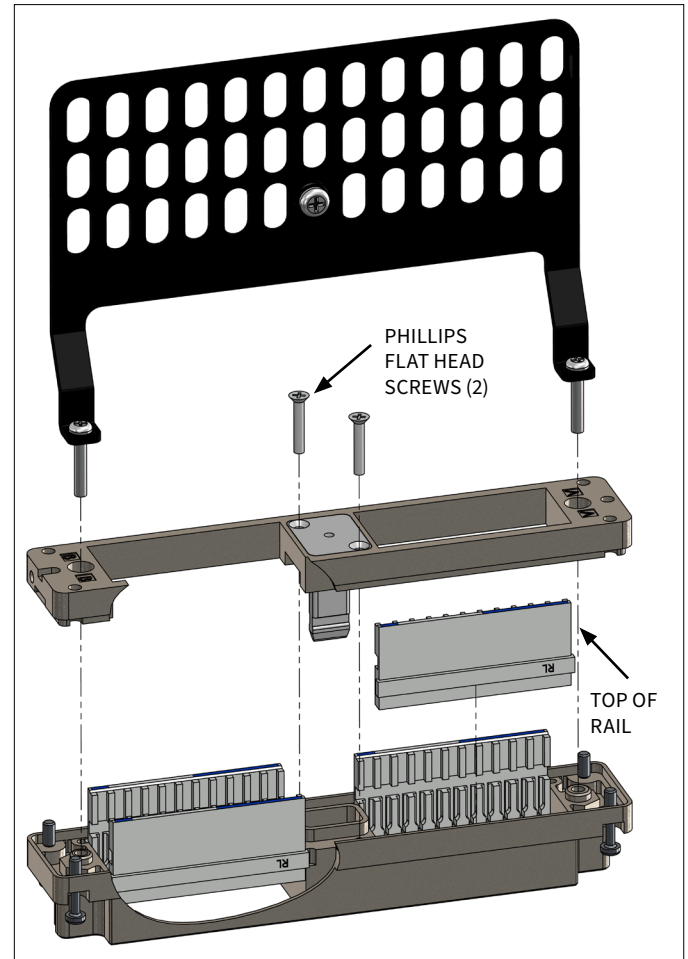

Figure A. VTAC HSD Rail(s) install/removal (receiver shown).

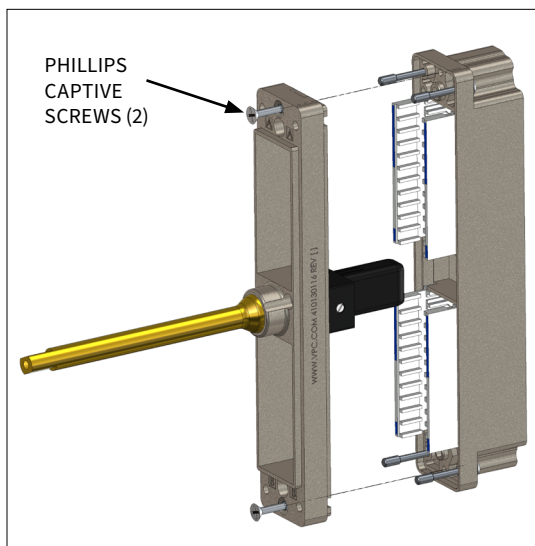

Figure B. ITA frame separation.

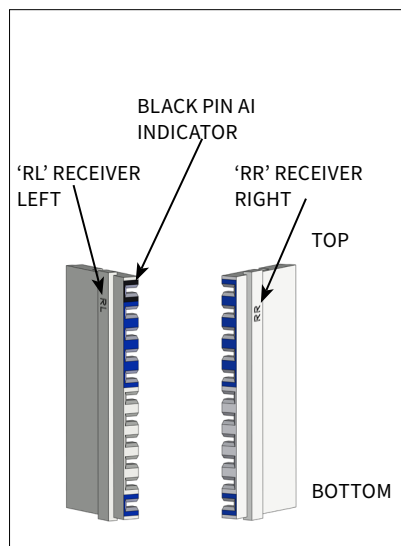

Figure C. VTAC HSD Rail(s) - Identifiers.

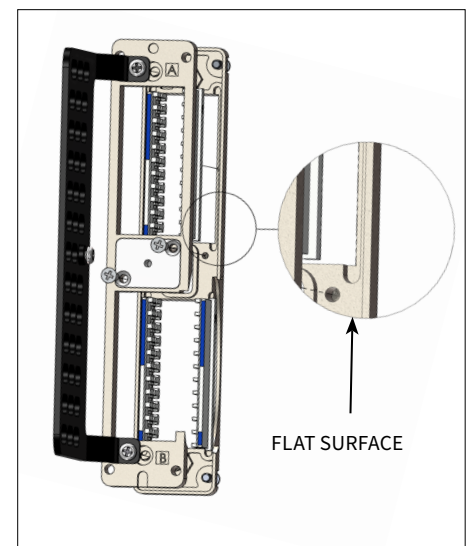

Figure D. VTAC HSD Rail(s) install/removal (receiver shown).

[RETURN TO INDEX](#)

RECEIVER STRAIN RELIEF ASSEMBLY

PART # 310113681

TOOLS REQUIRED

Phillips Head Screwdriver

ASSEMBLY INSTRUCTIONS

- Using the Phillips head screwdriver, fasten the strain relief to the back (wiring) side of the i2 MX receiver with the 2-56 screws and nuts provided (**Figure A**). Place the nuts in the keying positions from the front side of the receiver.

*NOTE: If using the keying features, replace the 2-56 nuts with the keying pins (**Figure B**).*

- Torque screws to 3.5 in-lbs [0.4 Nm] Strain Relief and 3.5 in-lbs [0.4 Nm] Keying.

NOTE: Four wiring ties are included with the strain relief for restraining wires.

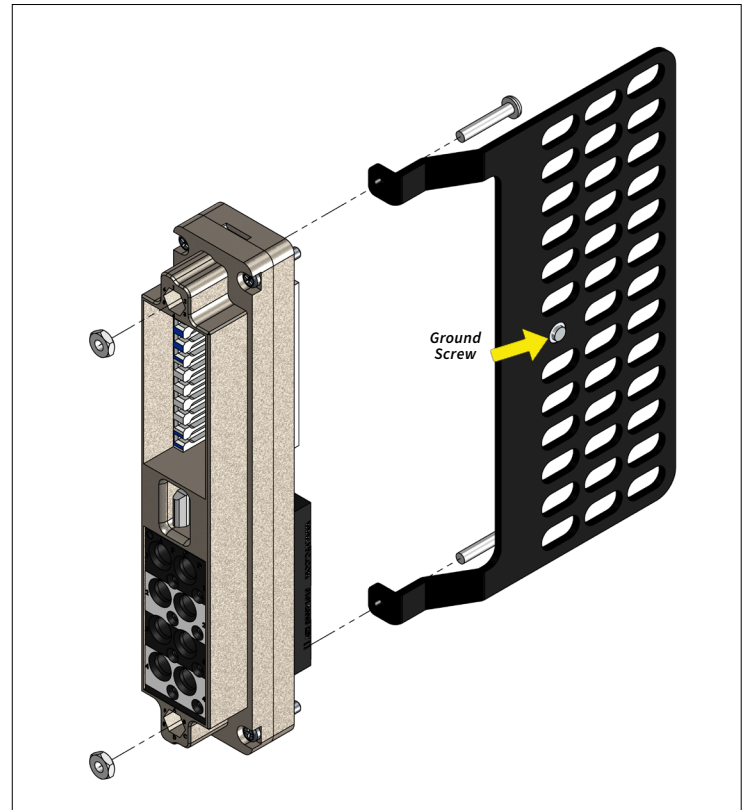

Figure A. i2 MX receiver strain relief.

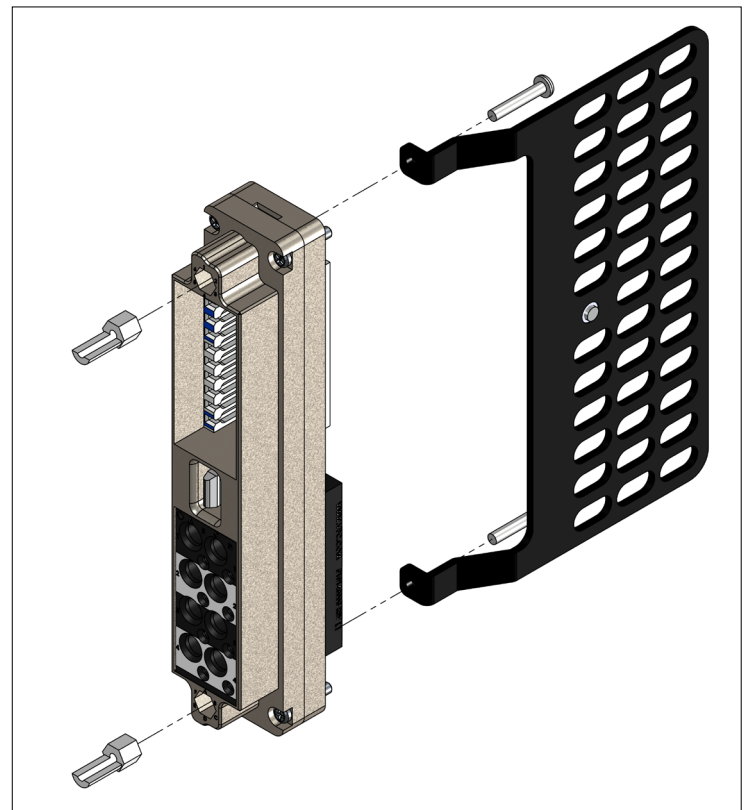

Figure B. i2 MX receiver strain relief with keying pins.

[RETURN TO INDEX](#)

PROTECTIVE COVER USE

PART # 310113667, 410113208

INSTALLATION INSTRUCTIONS

1. Turn the engagement knob counter-clock wise to the fully disengaged position.
2. Snap the cover on to the ITA.
3. Turn the engagement knob clock wise to the fully engaged position

REMOVAL INSTRUCTIONS

1. Turn the engagement knob counter-clock wise to the fully disengaged position.
2. Pull outward to remove the cover.

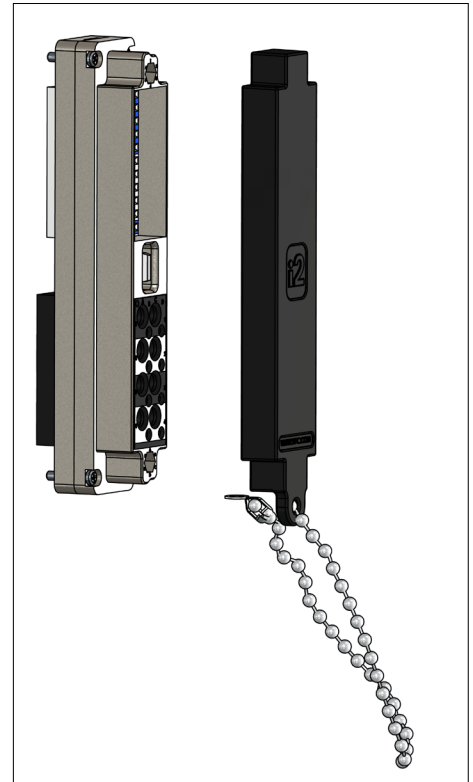

Figure A. i2 MX receiver protective cover.

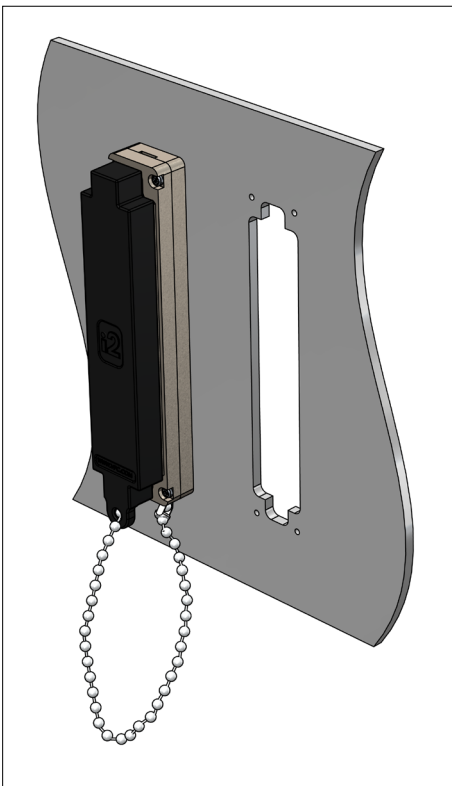

Figure B. i2 MX receiver protective cover installed.

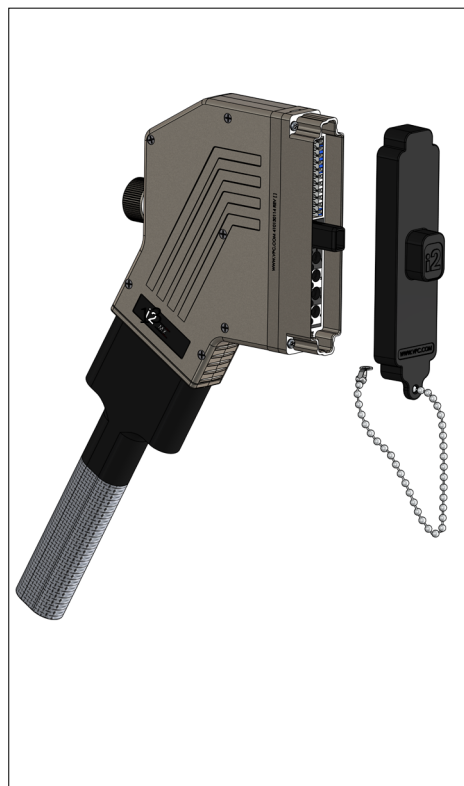

Figure C. i2 MX ITA protective cover.

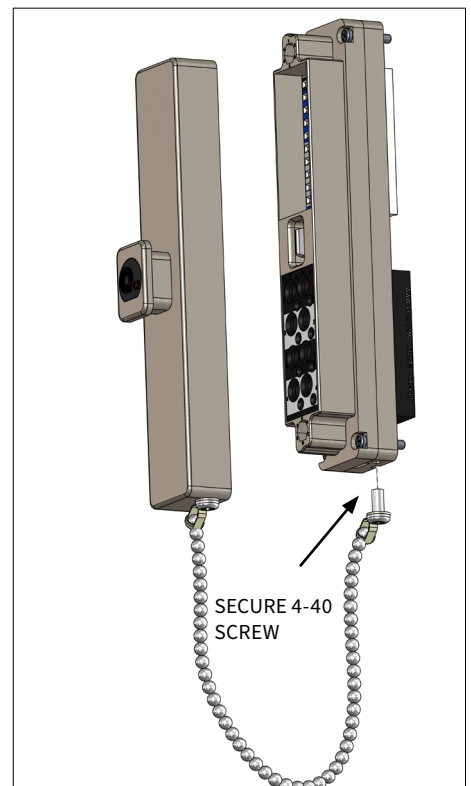

Figure D. i2 MX EMI receiver protective cover.

[RETURN TO INDEX](#)

KEYING PIN KIT ITA AND RECEIVER INSTALLATION

PART # 310113461

The iSeries keying kit includes two pins and screws which provide six different keying options. The i2 MX system is designed to accept two kits which increase the keying options to 36.

TOOLS REQUIRED

Phillips Head Screwdriver

ASSEMBLY INSTRUCTIONS

1. Determine the keying pin's desired orientation (**Figure A**).
2. Using a Phillips head screwdriver, secure a keying pin in the i2 MX receiver with the (2) 56 screws provided with the keying pin kit (**Figure B**). Torque screws to 3.5 in-lbs [0.4 Nm]

NOTE: If the strain relief plate, Part # 310113681, is being used, replace the screws used to secure the keying pins with the screws included with the strain relief plate.

3. Remove the ITA cover (see Section 4).
4. Using a Phillips head screwdriver, secure a keying pin in the i2 MX ITA with the 2-56 screws provided (**Figure C**). Torque screws to 3.5 in-lbs [0.4 Nm].
5. Replace the i2 MX ITA cover (see **Section 4**).

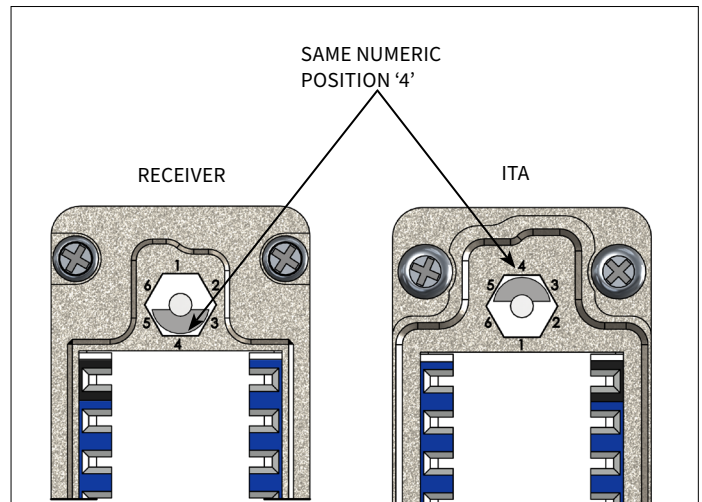

Figure A. i2 MX receiver and ITA mating faces. In order to mate the connector, the keying pin must be in the same numeric position in both the receiver and ITA.

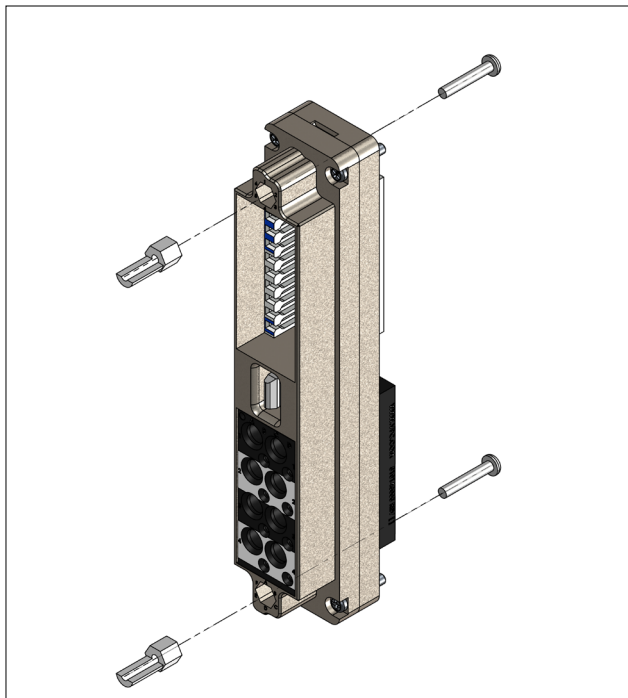

Figure B. i2 MX receiver with keying pins.

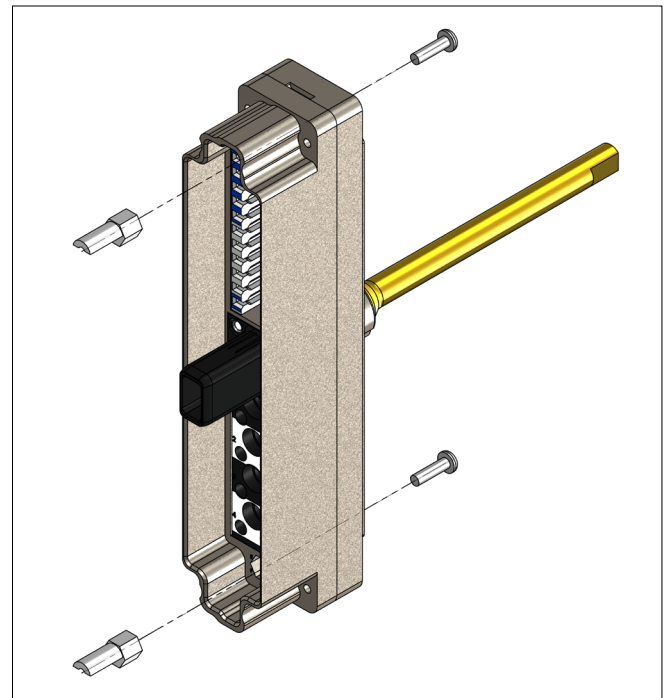

Figure C. i2 MX ITA with keying pins.

[RETURN TO INDEX](#)

STANDARD PCB LAYOUTS

TWO QUADRAPADDLE MODULE INSERTS

PART # 310130202

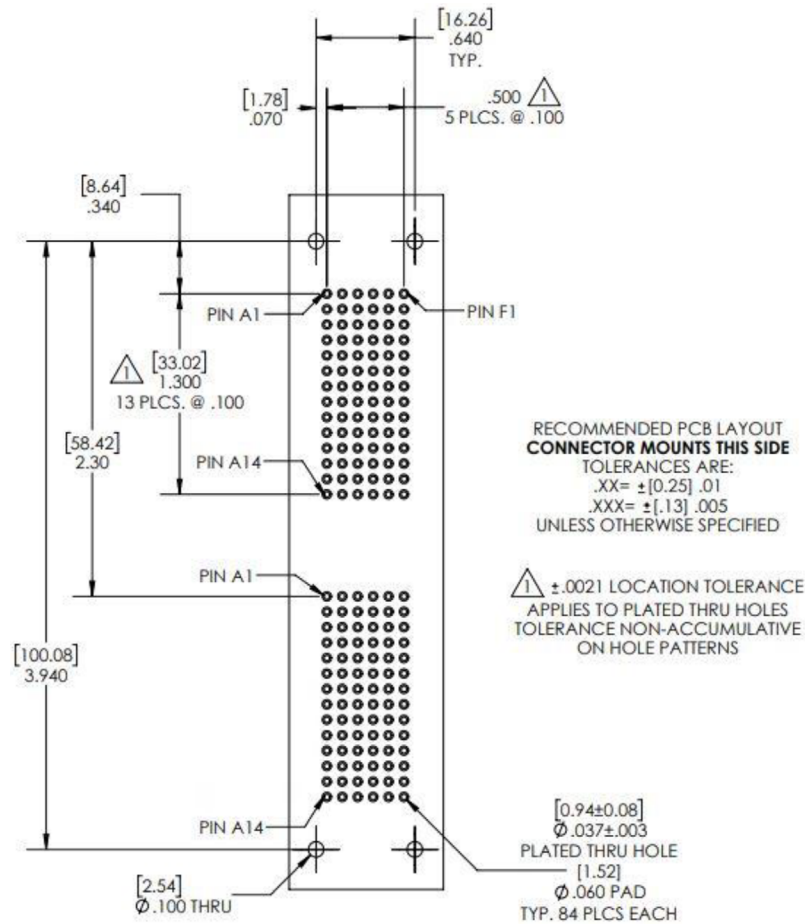

Figure A. PCB layout for i2 MX receiver, Part # 310130202. Thru hole and pad diameters are for VPC QuadraPaddle Adapter Contacts, Part # 610138117. The size of these holes may be different if a header from a different manufacturer is used. Connector mounts this side.

STANDARD PCB LAYOUTS CONTINUED

ONE QUADRAPADDLE MODULE INSERT AND ONE
MICRO POWER/COAX MODULE INSERT
PART # 310130205

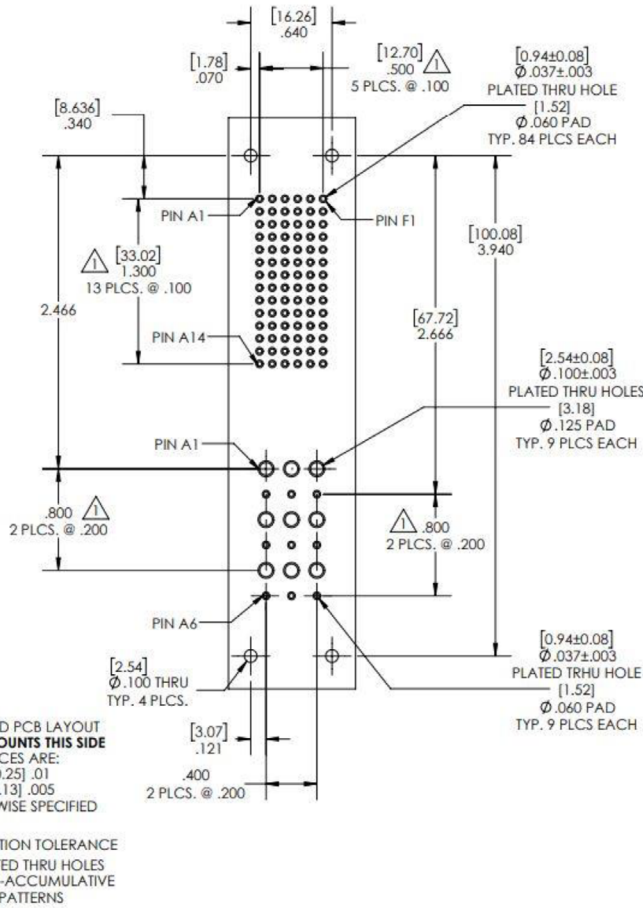

Figure B. PCB layout for i2 MX receiver, Part # 310130205. Thru hole and pad diameters are for VPC QuadraPaddle Adapter Contacts, Part # 610138117, and for Micro Coax and/or Micro Power contacts. The size of these holes may be different if a header from a different manufacturer is used. Connector mounts this side.

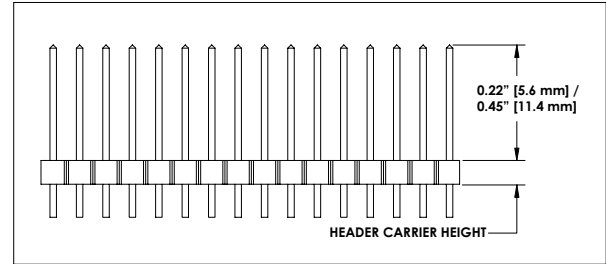

Figure C. Twin male header.

NOTE: (Figure C) details 0.22" [5.59 mm]/0.45" [11.43 mm] min/ max engagement.
NOTE: Minimum spacer height = 0.24" + header carrier height - panel thickness (if used).
 Any additional height beyond this minimum must be added to the header post limits shown in (Figure C).
NOTE: Several manufacturers offer the twin male header: Samtec, TE, MultiComp, Molex. The specific part number required is dependent on the distance the i2 will be located from the PCB, the thickness of the PCB, and the plating type required.

i2 MX STANDARD PCB LAYOUTS CONTINUED

2 TRIPADDLE SIGNAL/MICRO POWER AND MICRO COAX MODULE

INSERTS

PART # 310130204

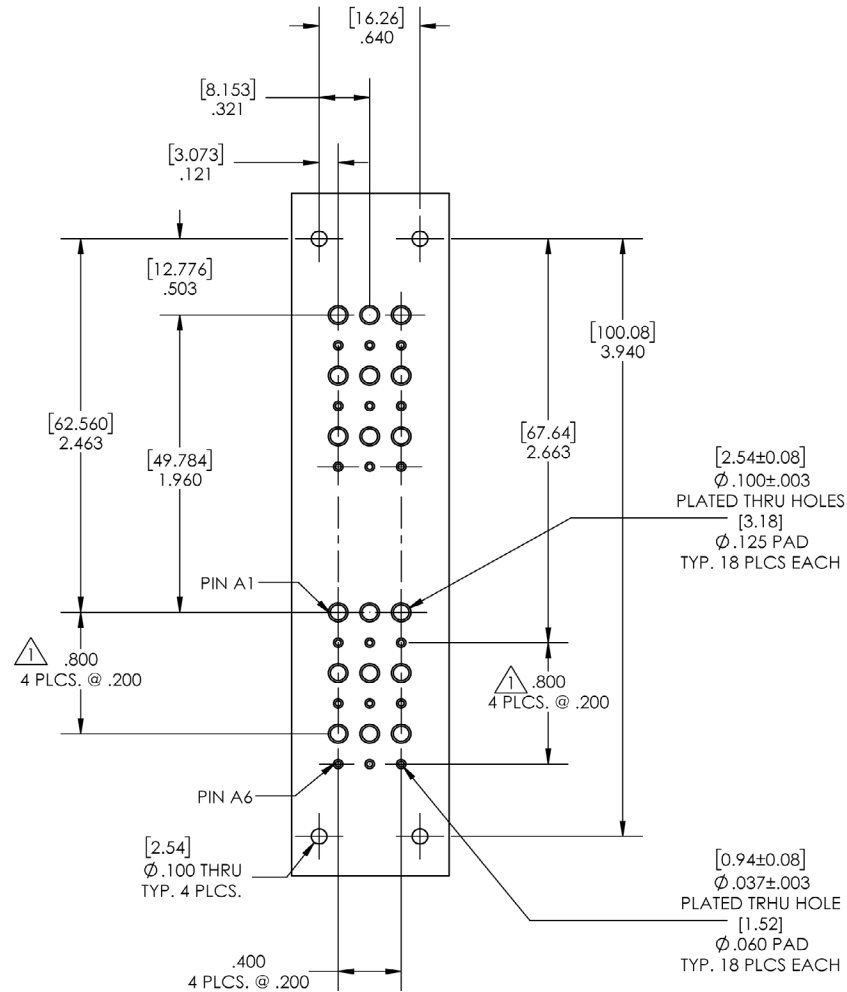

Δ ±.0021 LOCATION TOLERANCE
 APPLIES TO PLATED THRU HOLES
 TOLERANCE NON-ACCUMULATIVE
 ON HOLE PATTERNS

Figure A. PCB layout for i2 MX receiver, Part # 310130205. Thru hole and pad diameters are for Micro Coax and/or Micro Power contacts. The size of these holes may be different if a header from a different manufacturer is used. Connector mounts this side.

[RETURN TO INDEX](#)

i2 MX RIGHT ANGLE VTAC PCB LAYOUT

PART # 310130113, 310130139, 610151103, 610151104

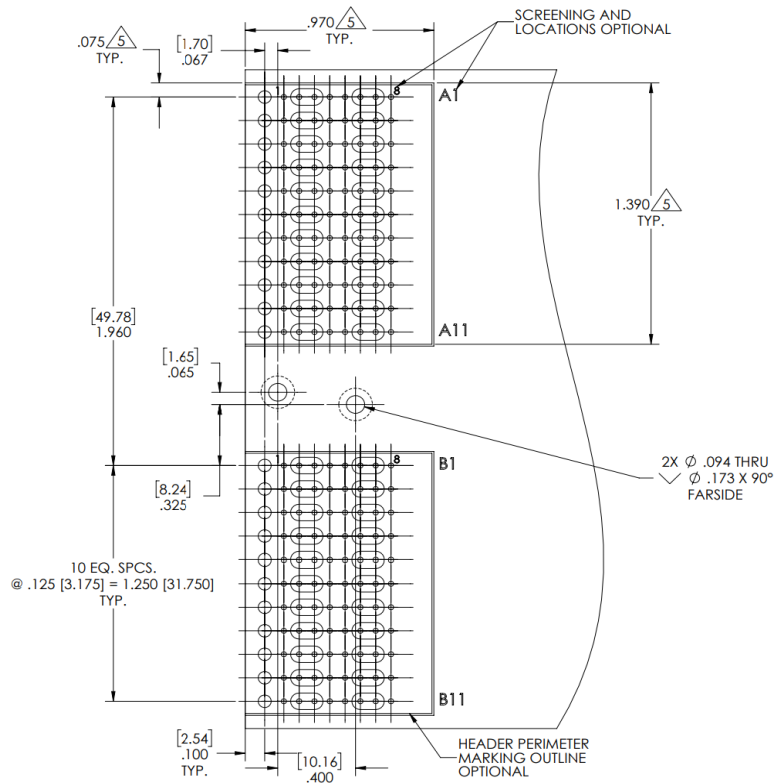

I2 MX PCB LAYOUT COMPONENT (VTAC) SIDE SHOWN

NOTE: Install/Extract VTAC Pass-Thru and Right Angle Inserts per the VTAC User Manual.

RIGHT ANGLE CONTACT LENGTHS \triangle

PIN #	TOTAL LENGTH
1	0.643 [16.3322]
2	0.747 [18.9738]
3	0.87 [22.098]
4	0.999 [25.3746]
5	1.128 [28.6512]
6	1.256 [31.9024]
7	1.385 [35.179]
8	1.517 [38.5318]

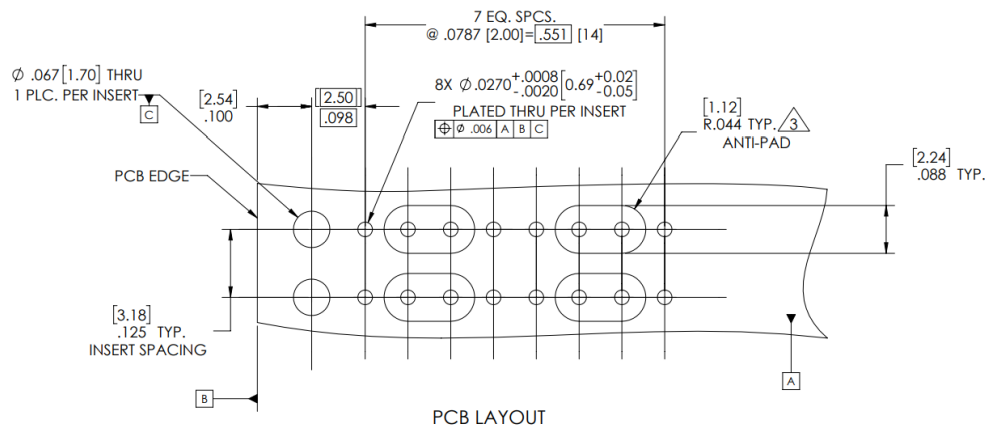

[RETURN TO INDEX](#)

TROUBLESHOOTING

ITA frame is not lined up when in the process of engagement with receiver

This may indicate that the ITA is out of alignment or that a module is not mating with its intended mate.

- Remove and inspect the ITA for alignment.
- Check for foreign objects/tools.
- Inspect the matching of modules - Signal ITA Module to mate with Signal Receiver Module, etc.
- The keying pin locations do not mate.



Forceful engagement of the Receiver and the ITA will result in serious damage to multiple parts of the system (modules, receiver, ITA and contacts)!