



PULL-THRU SYSTEMS & ADAPTERS

G20, G20x, G40x

INDEX (CLICK TO NAVIGATE TO PAGE)

[2 INTERCONNECT ADAPTER RECOMMENDED PCB LAYOUT](#)

[3 INTERCONNECT ADAPTERS & PCB COMPATIBILITY](#)

[4 PREPARING PXI CARD FOR MATING TO INTERCONNECT ADAPTER](#)

[5 MOUNTING PCB & MATING TO INTERCONNECT ADAPTER](#)

[6 MATING WIRED INTERCONNECT ADAPTER TO PXI CARD](#)

[7 INSTALLING INTERCONNECT ADAPTER ASSEMBLY INTO RECEIVER](#)

[8 G20/ G20X RECEIVER INSTALLATION](#)

[10 G20/ G20X SLIDE INSTALLATION](#)

[11 G40X RECEIVER INSTALLATION](#)

[15 RECEIVER HANDLE REPOSITIONING AND REMOVAL](#)

[16 MICROSWITCH REPLACEMENT](#)

[17 ITA & RECEIVER ENGAGEMENT](#)

[18 TROUBLESHOOTING & PRECAUTIONARY NOTES](#)

*Please note that any printed or downloaded User Manual may not reflect the most current revisions.
The information contained herein is subject to change.
For the most current information available, visit vpc.com.*

INTERCONNECT ADAPTER RECOMMENDED PCB LAYOUT

PART # 510109461

When using VPC's Interconnect Adapter for PCB connection to a PXI card, use VPC's recommended PCB layout (**Figure A**).

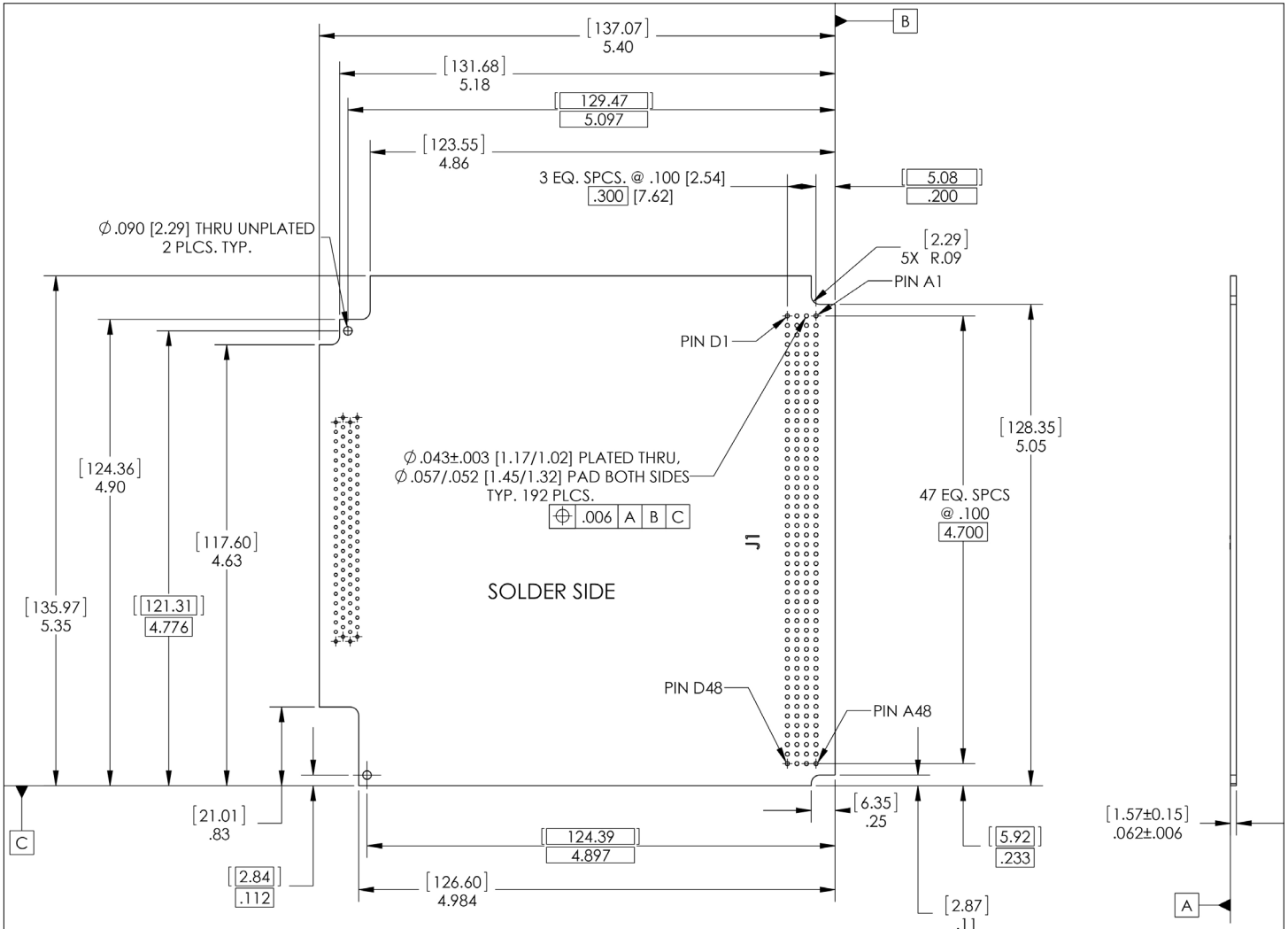

Figure A.

[RETURN TO INDEX](#)

INTERCONNECT ADAPTERS AND PCB COMPATIBILITY

PART # 510109461, 510150152

Dimensions [millimeters]
shown: inches

1. During PCB design, ensure the height of PCB components fit within the maximum allowable PCB component space of the interconnect adapter. Component height cannot exceed .580" [14.7] (**Figure A**).
2. The vertical distance from the C datum of the interconnect adapter's PCB to the PXI card mounting hole is 0.030". The horizontal distance from the B datum to the rear of the PXI face plate is 5.718" (**Figure B**).
3. Solder the header from QuadraPaddle Receiver Module (p/n 510 150 152) and the mating PXI connector to the PCB. IPC-A-610 standard is recommended for PCB design.
3. Trim all solder leads to a max length of 0.040" [1.016].

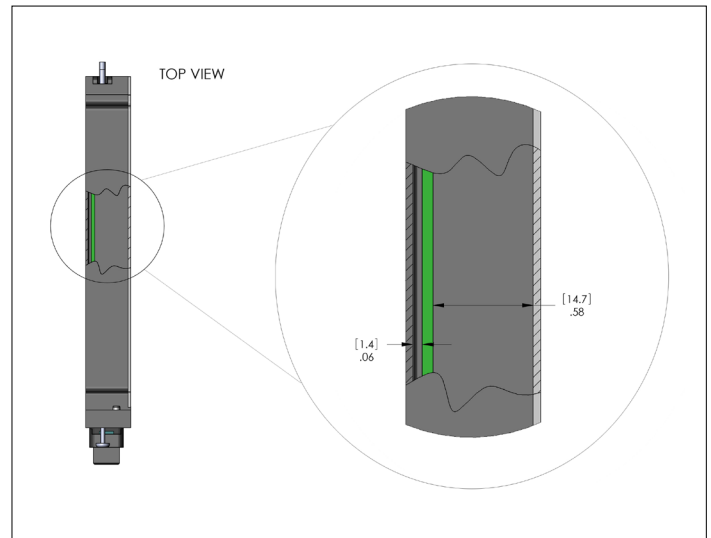

Figure A. Maximum allowable PCB component space.

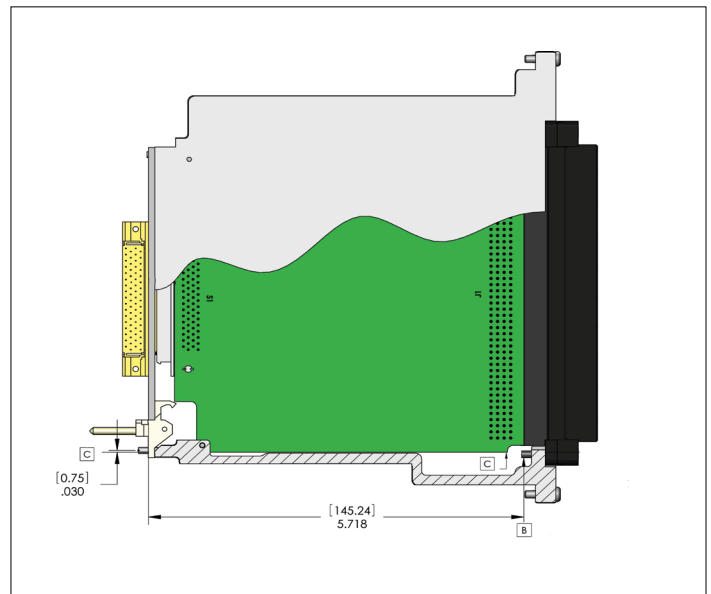

Figure B.

[RETURN TO INDEX](#)

PREPARING PXI CARD FOR MATING TO INTERCONNECT ADAPTER

PART # 510109461

TOOLS REQUIRED

Hammer
Phillips head screwdriver
 $\frac{1}{16}$ " punch
2.5 mm Allen Wrench

1. Use $\frac{1}{16}$ " punch with hammer to remove the ejector dowel pin at the bottom of the PXI card (**Figure A**). Use care not to drop spring which is loaded inside tab.
2. With the dowel pin removed, separate the ejector tab from the face of the instrument card. (**Figure B**). Remove top card mounting screw.
3. Store ejector tab, spring, dowel pin, and card mounting screws in a safe location, in case needed in for future use (**Figure C**).
4. Card is now ready to mate with PXI adapter.

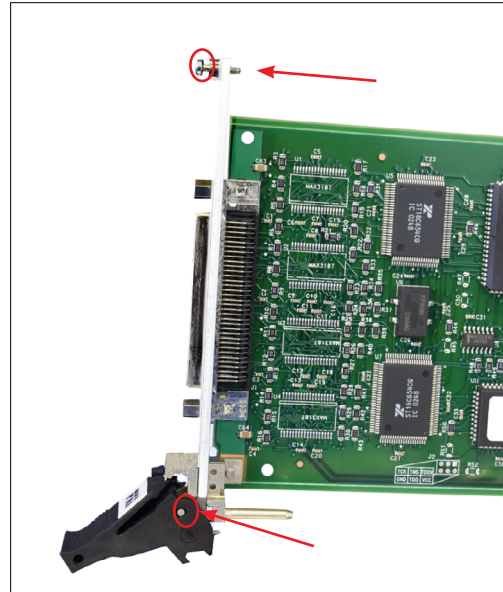

Figure A.



Figure C. Save and store card parts not being used.

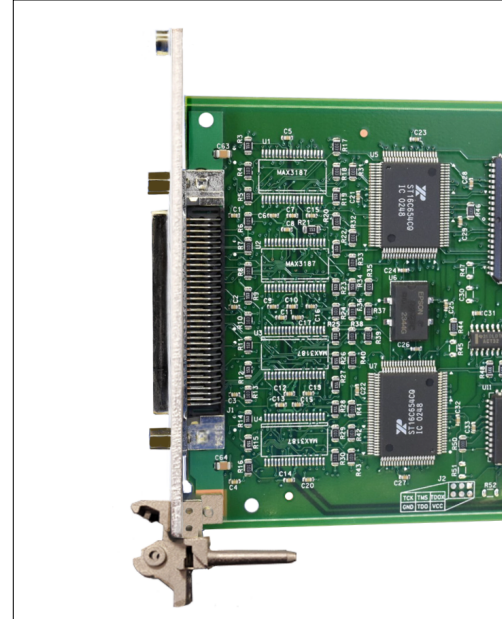

Figure B. Card with ejector tab and top mounting pin removed.

[RETURN TO INDEX](#)

MOUNTING PCB AND MATING TO INTERCONNECT ADAPTER

PART # 510109461

TOOLS REQUIRED

$\frac{3}{32}$ Allen Wrench

Phillips head screwdriver

1. Remove the top cover from the interconnect adapter using a Phillips head screwdriver.
2. Lay the PCB assembly inside the interconnect adapter and secure the fastening screws with the Phillips head screwdriver (**Figure A**).
2. Install selected VPC receiver module to the front of the interconnect adapter assembly with the $\frac{3}{32}$ Allen Wrench (**Figure B**). Pin 1 should be in the top left position.
3. Mate the PXI card connector with the interconnect adapter's PCB connector. Secure using the (2) M2 screws provided (**Figure C**).
4. Reassemble the cover plate onto the interconnect adapter using a Phillips head screwdriver (**Figure D**).

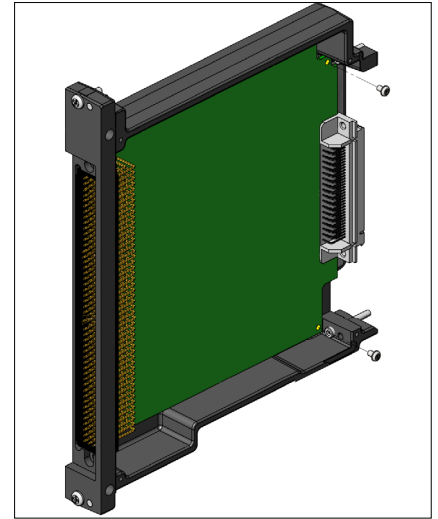

Figure A.

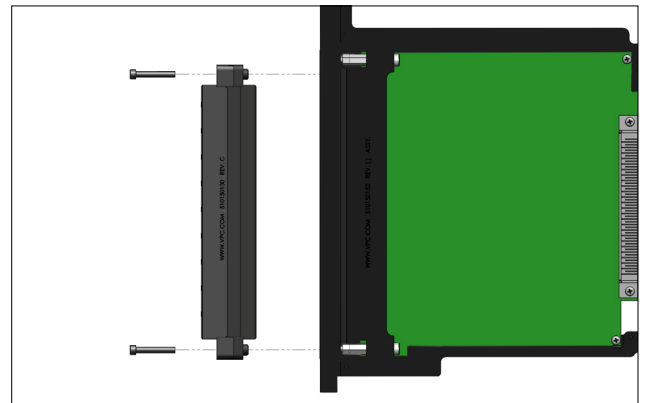

Figure B.

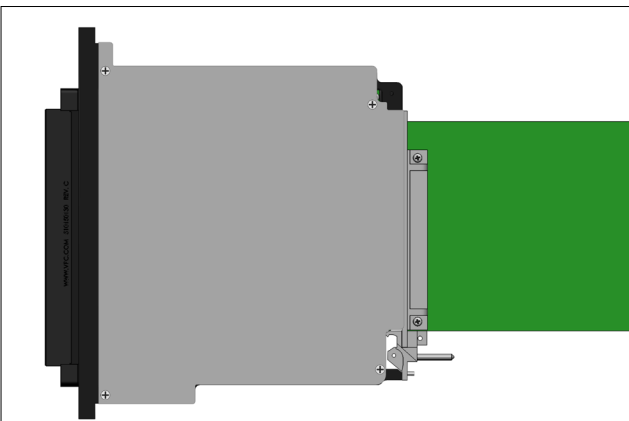

Figure D. Reassemble cover plate.

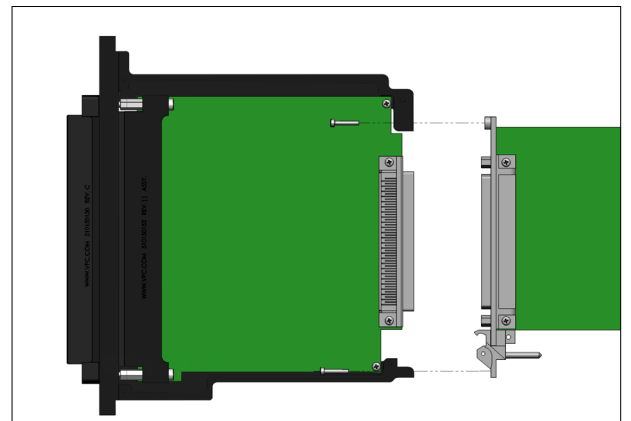

Figure C. Mate and secure PXI card to the interconnect adapter.

[RETURN TO INDEX](#)

MATING WIRED INTERCONNECT ADAPTER TO PXI CARD

PART # 510109461

TOOLS REQUIRED

$\frac{3}{32}$ Allen Wrench

Phillips head screwdriver

1. Remove the top cover from the interconnect adapter using a Phillips head screwdriver (**Figure A**).
2. Remove the module mounting screws from the receiver module using a $\frac{3}{32}$ Allen wrench and pull the module forward to separate (**Figure B**).
3. Be sure wired connector is slightly recessed inside the interconnect adapter frame. Secure the PXI card to the interconnect adapter frame using the (2) M2 screws provided (**Figure C**).
4. Mate the wired connector with the PXI card connector (**Figure D**).
5. Reassemble the cover plate on the interconnect adapter using a Phillips head screwdriver (**Figure E**).
6. Using a $\frac{3}{32}$ Allen wrench, secure the receiver module to the interconnect adapter frame.

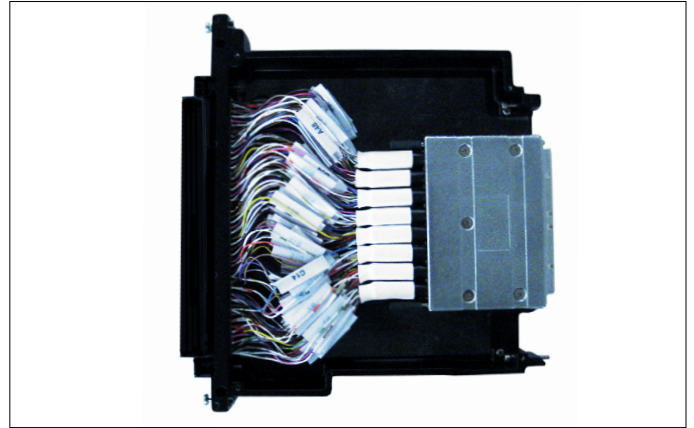

Figure A. Cover removed.

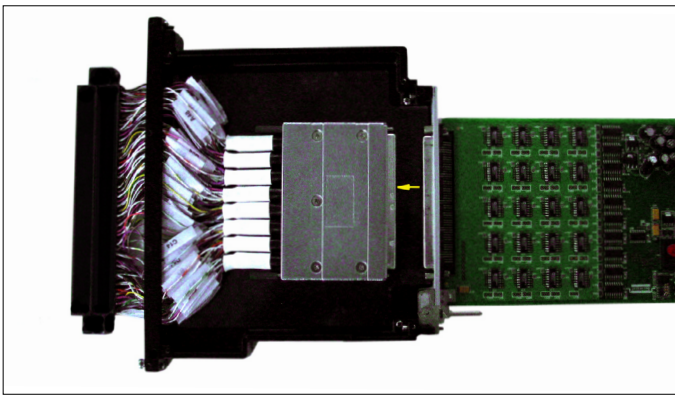

Figure C. Be sure wired connector is recessed slightly inside adapter.

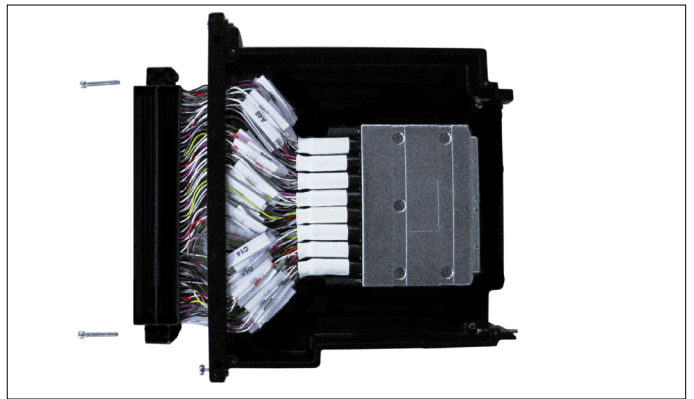

Figure B. Remove module mounting screws.

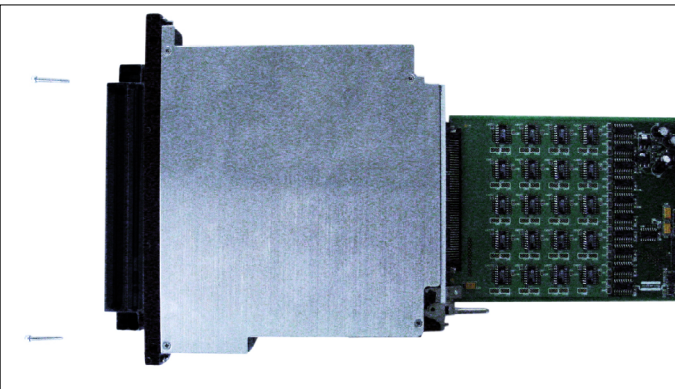

Figure E. Reassemble cover plate.

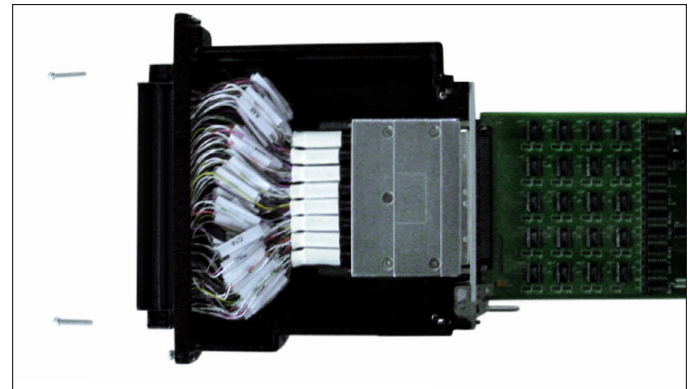

Figure D. Mate connectors.

[RETURN TO INDEX](#)

INSTALLING INTERCONNECT ADAPTER ASSEMBLY INTO RECEIVER

PART # 510109461

NOTE: (p/n 510109462) The module adapter plate allows users to mount a discrete wired 90 series module in the receiver frame without the use of a pull thru adapter.

TOOLS REQUIRED

Phillips head screwdriver

1. Line-up card in chassis slot. Ensure distance between receiver and chassis allows for card to be fully inserted into chassis.
2. Secure the adapter to the receiver frame with the (2) captive M3 screws and Phillips head screwdriver (**Figure A**).
3. G20 Receiver module positions are shown in (**Figure B**).
4. VPC recommends that Pin Position 1 always be located to the left in the receiver and ITA.

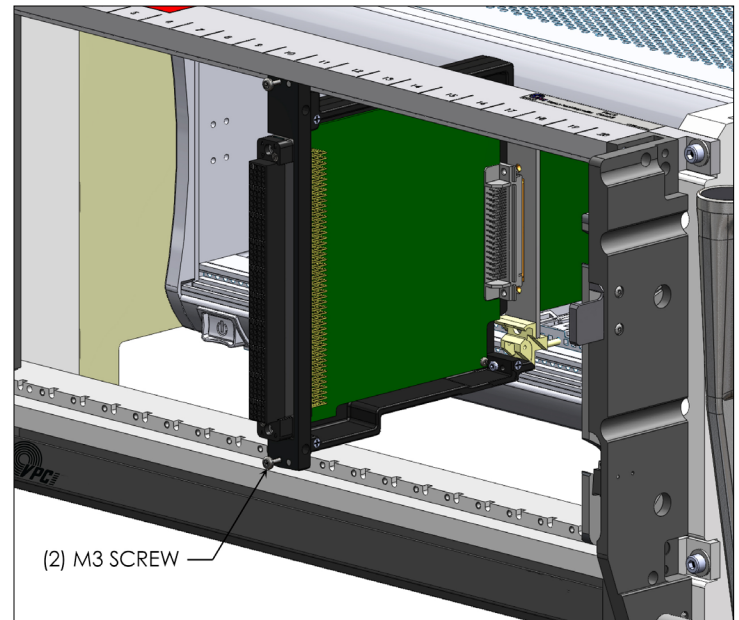

Figure A. Secure adapter to the receiver frame

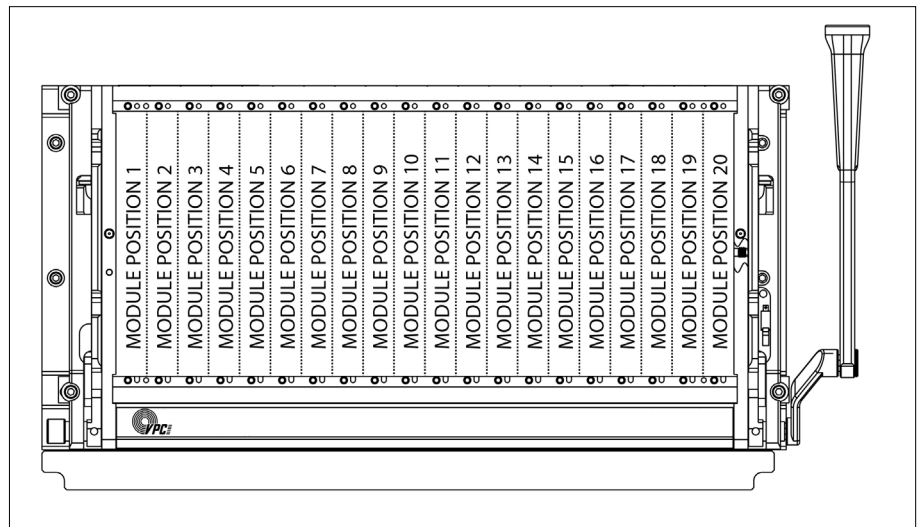

Figure B. G20 receiver module positions

[RETURN TO INDEX](#)

G20/ G20X RECEIVER INSTALLATION

PART # 310120186, 310120188

TOOLS REQUIRED

- Flat Head Screwdriver
- 4 mm Hex Wrench
- Phillips Screwdriver

FLANGE INSTALLATION

1. Separate the receiver mounting frame from the receiver.
2. Attach the receiver mounting frame to the flanges using M4 x 8 flat head screws (**Figure A, B**).
3. Slide onto the PXI chassis from the front, ensuring each flange side remains on the outer edge and aligns with the correct screw holes on the chassis.
4. Secure each flange to the side of the chassis using (16) M4 x 12 flat head screws (**Figure C**).
5. With the PXI chassis oriented as shown (**Figure D**), attach the receiver to the mounting frame using the M5 x 16 mounting screws. **DO NOT fully** tighten the mounting screws at this point.

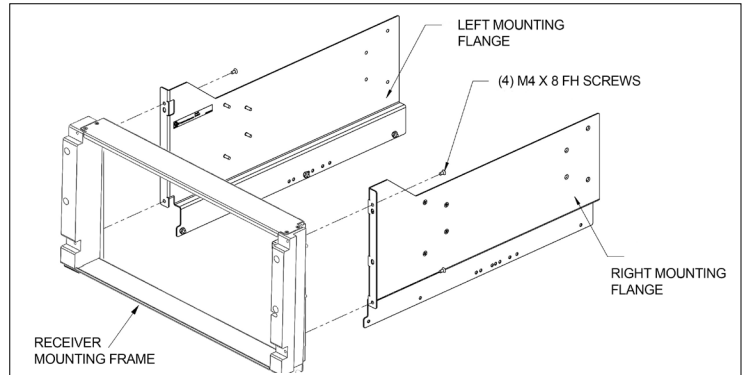

Figure A. G20 mounting frame.

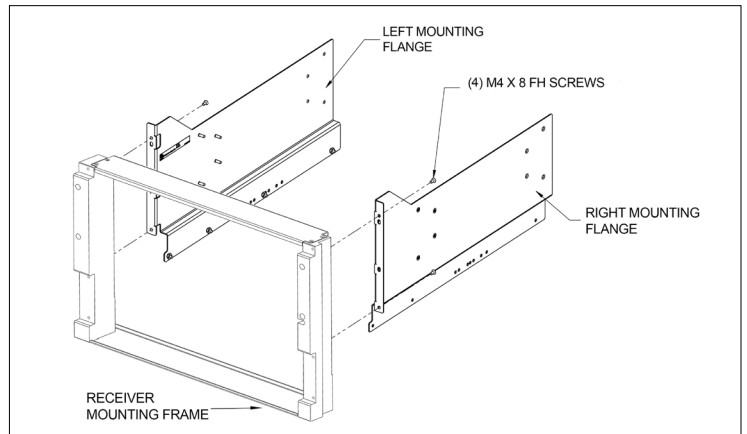

Figure B. G20x mounting frame.

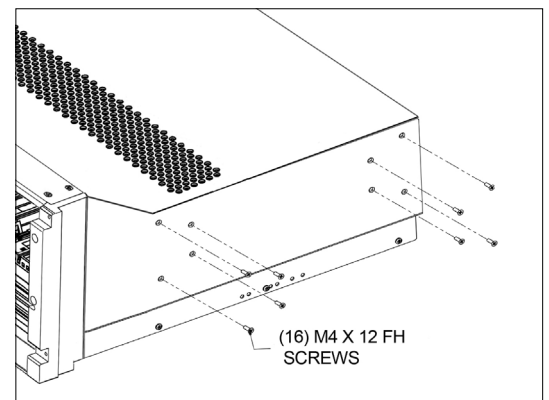
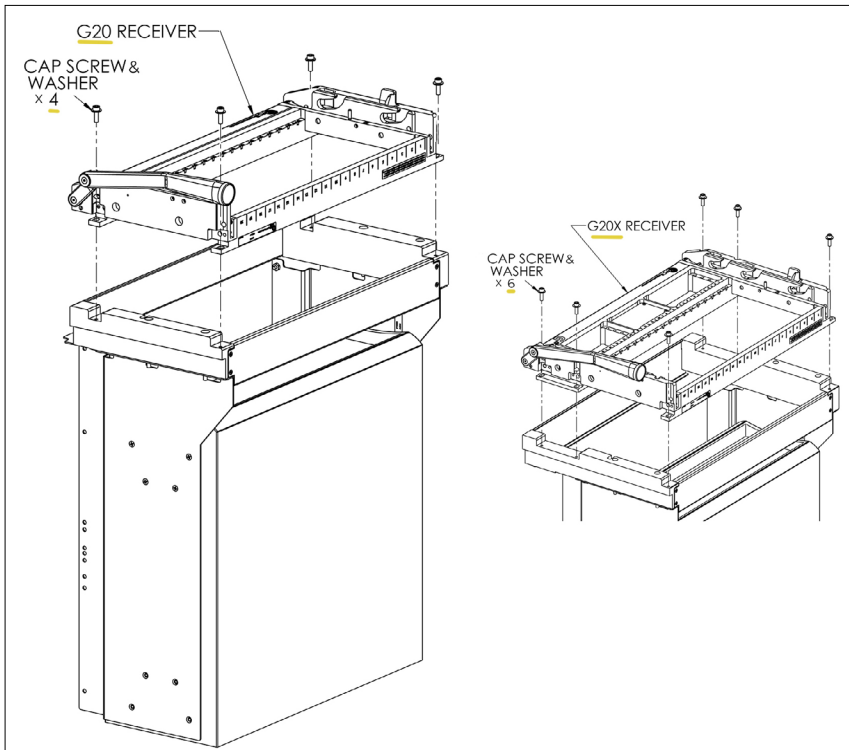

Figure C. Secure the flanges to the sides of the chassis.

Figure D. Attach the receiver to the mounting frame assembly. The G20 requires (4) screws & washers; G20x requires (6).

[RETURN TO INDEX](#)

G20/ G20X RECEIVER INSTALLATION (CONT'D)

PART # 310120186, 310120188

RECEIVER ALIGNMENT

1. In order to prevent the weight of the receiver from impacting the alignment process, ensure the chassis assembly is still oriented as show in **(Figure A)**.
2. Install (2) interconnect adapters with cards attached, into module positions # 4 and # 20 **(Figure B)**. Secure each adapter to the receiver by tightening the captive screws.
3. With the interconnect adapters secured in place, the receiver's (4) M5 x 16 mounting screws may now be fully tightened, thus completing alignment of the receiver.
4. Once the receiver and mounting frame have been aligned and securely attached to the flange assembly, the interconnect adapters may be moved to other locations, as needed.

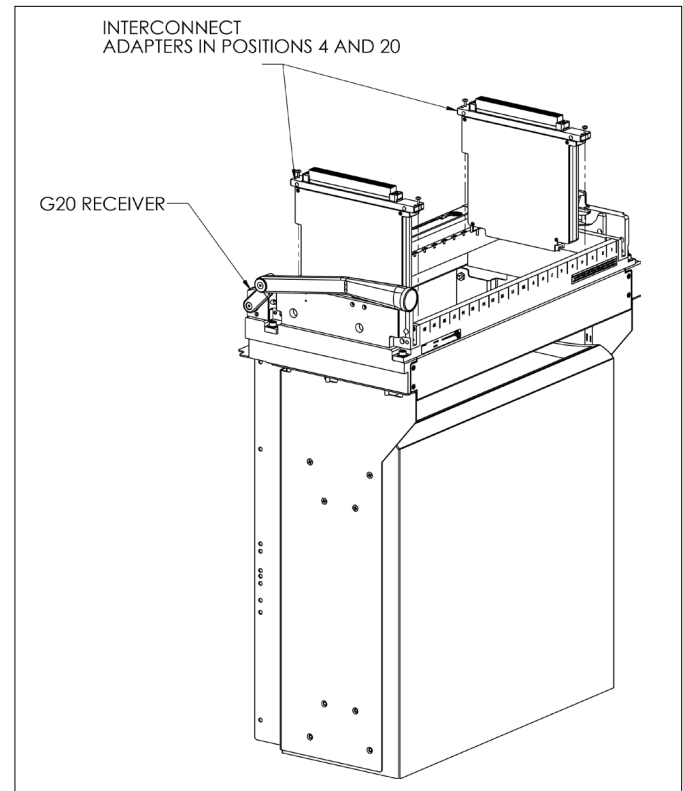

Figure A. Install (2) interconnect adapters with cards attached

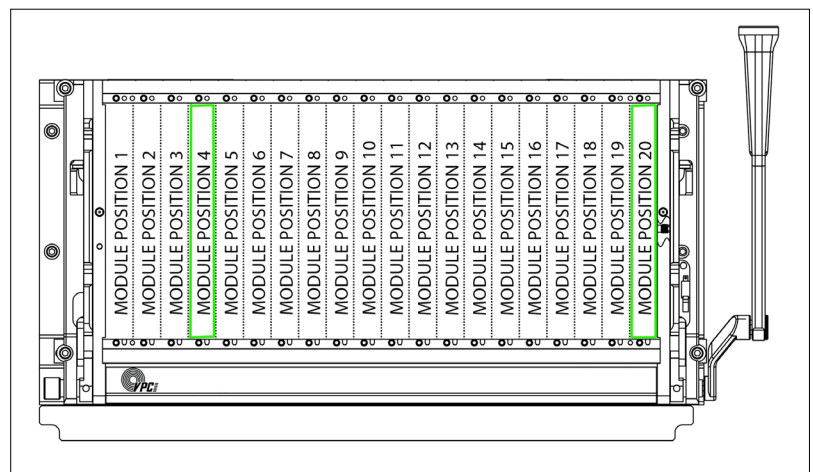

Figure B. Install in positions #4 and #20.

[RETURN TO INDEX](#)

G20/ G20X SLIDE INSTALLATION

PART # 310120188, 310120186

TOOLS REQUIRED

Flat Head Screwdriver

$1\frac{1}{32}$ Hex Wrench

Phillips Screwdriver

- Slide kits are sold by length and length is decided by rack depth in inches. Rack depth is calculated using dimension A (**Figure A**). Slide length should not exceed dimensions A + B.
- In the example shown (**Figure A**), dimension A= 29.5" [749.3], which is best accommodated by the 30" Slide Kit, which fits 28"- 32" deep racks, VPC p/n [310113411](#). A full listing of all available slide kits is available at [vpc.com](#).
- Install (2) slides on the rack according to the manufacturer's instructions (included with slides or [click here](#)).
- Remove small inside slide rails from the larger outer slides (**Figure B**).
- Attach the inside rails to the previously assembled receiver/ chassis/ flange assembly using the (8) 8-32 x .375 long pan head screws, lock washers, and nuts (**Figure C**).
- Insert the small rails, now assembled onto the chassis assembly, into the larger rack-installed slides until they snap into place (**Figure D**).

Dimensions [millimeters]
shown: inches

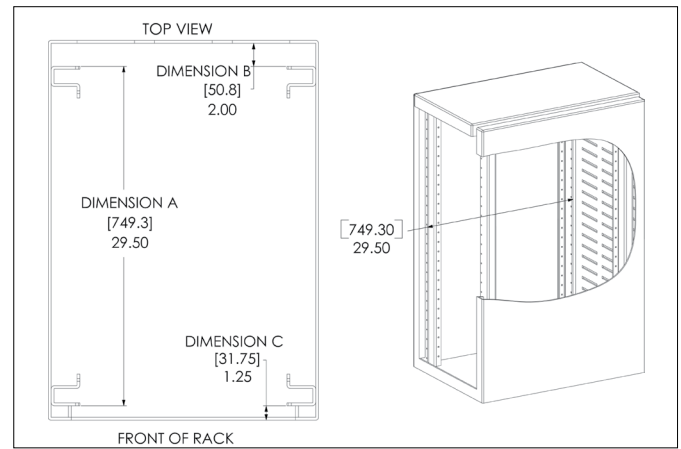

Figure A.

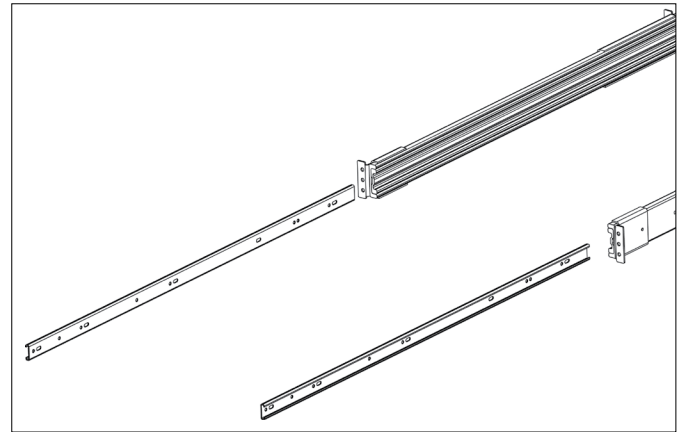

Figure B.

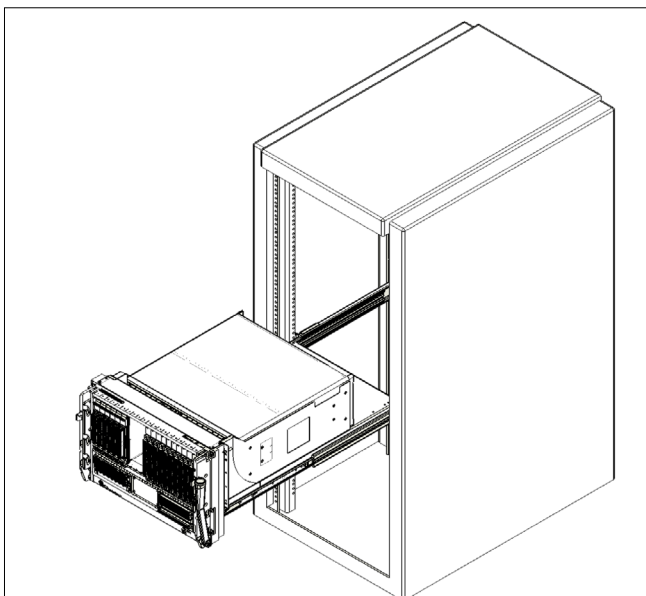

Figure D. Slide assembly into rack mounted slides.

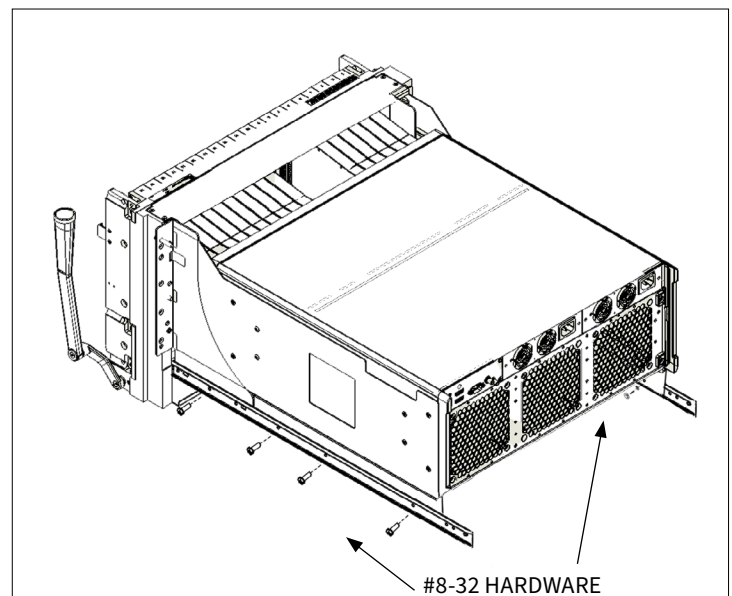

Figure C.

[RETURN TO INDEX](#)

G40X RECEIVER INSTALLATION

PART # 310120163, 310113784

TOOLS REQUIRED

- Flat Head Screwdriver
- 1½ Hex Wrench
- Phillips Screwdriver

SLIDE KIT SELECTION AND RACK INSTALLATION

1. Slide kits are sold by length and length is decided by rack depth in inches. Rack depth is calculated using dimension A (**Figure A**). Slide length should not exceed dimensions A + B.
2. In the example shown (**Figure A**), dimension A= 29.5" [749.3], which is best accommodated by the 30" Slide Kit, which fits 28"- 32" deep racks, VPC p/n [310113411](#). A full listing of all available slide kits is available at vpc.com.
3. The G40x is a two-tier system and thus, requires two sets of slides. Begin by installing both sets of slides to the rack according to the manufacturer's instructions (included with slides or [click here](#)).
4. Measurements for vertical placement of slides are shown (**Figure B**). Receiver and chassis should not be mounted at this point and are shown for visual reference only.
5. Fasten flanges from Mounting Flange Kit to chassis with the included (32) M4 x 12 mm flat head screws (**Figure C**).

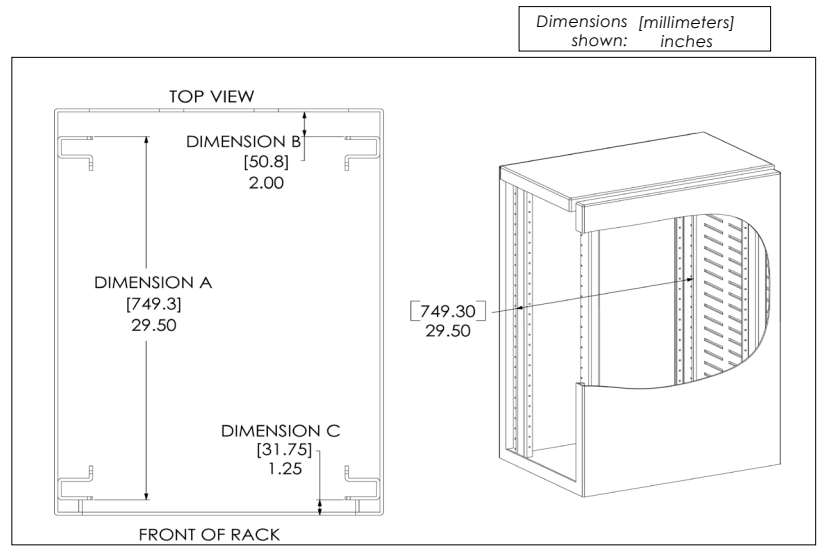

Figure A.

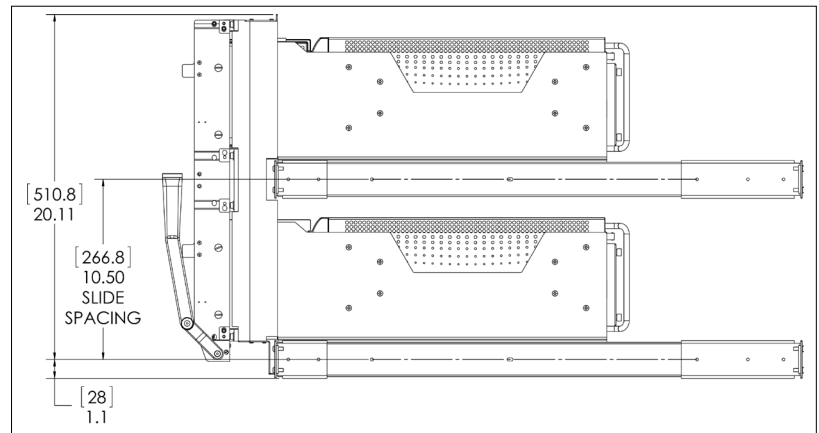

Figure B. Slide vertical placement measurements.

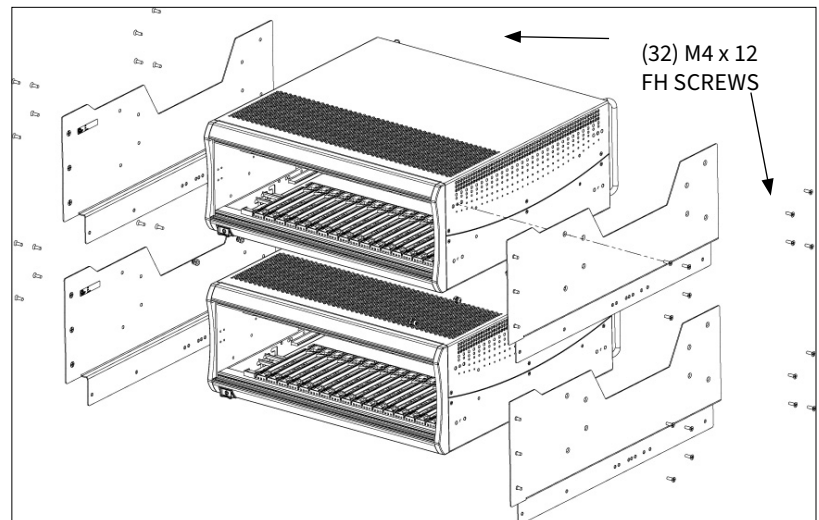

Figure C.

[RETURN TO INDEX](#)

G40X RECEIVER INSTALLATION (CONT'D)

PART # 310120163

CHASSIS TO RACK INSTALLATION

1. Remove small inside slide rails from the rack-installed slides. (**Figure D**).
2. Install the inner slides to the mounting flanges using the (16) #8-32 x .375 long button head screws, lock washers, and nuts (**Figure E**).
3. First install bottom chassis into rack by reinserting small slides, now mounted to chassis flanges, into larger rack-mounted slides. Slides should snap into place.
4. Push bottom chassis to the back, leveraging the weight of the chassis to the rear of the rack, to prevent the rack from tipping over (**Figure F**).
5. Repeat step 3 above for top chassis.

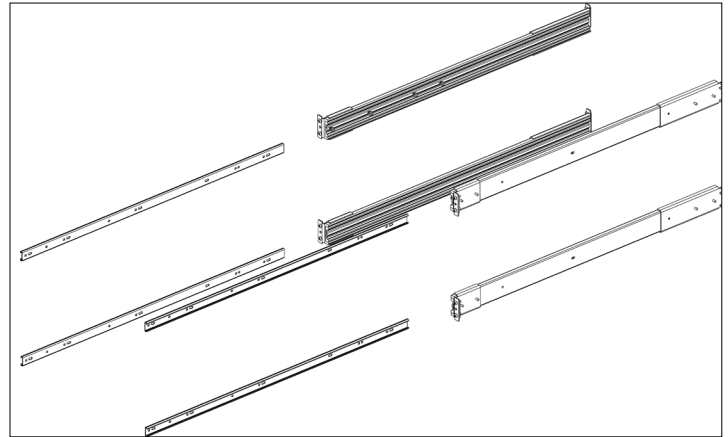

Figure D. Remove inner pieces of slides

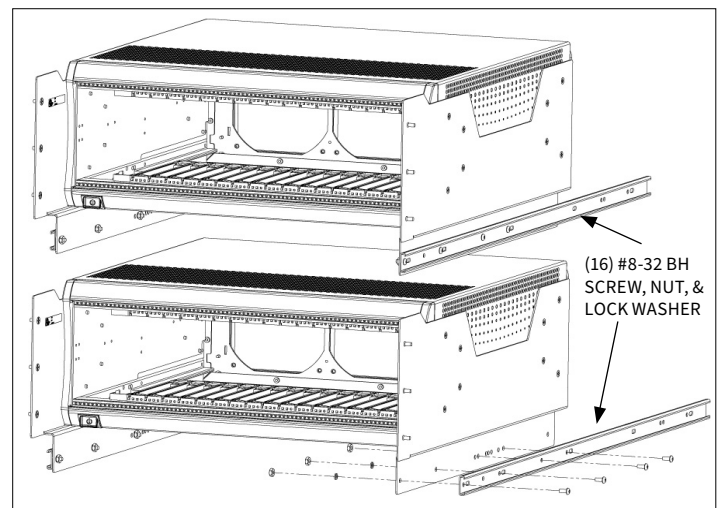

Figure E. Install inner slides onto chassis-mounted flanges.

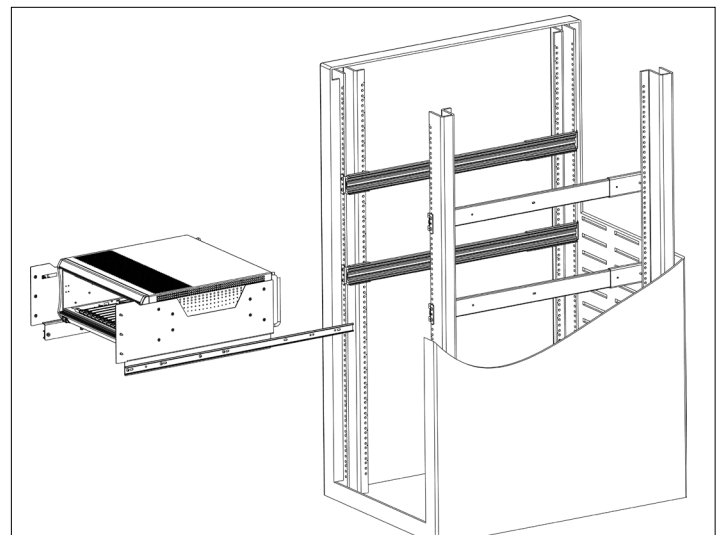

Figure F.

[RETURN TO INDEX](#)

G40X RECEIVER INSTALLATION (CONT'D)

PART # 310120163

RECEIVER MOUNTING

1. Remove the left and right mounting rails from receiver. Set the socket head cap screws and washers aside for later use.
2. Install the left mounting rail to the outside of the chassis flanges (**Figure G**) using (6) #8-32 x .375 long flat head screws and follow with the right mounting rail.
3. Due to the weight of the receiver, VPC recommends the use of two people for this step. Lift and place the receiver on the ledge at the top of the RH and LH mounting rails (**Figure H**).
4. Make sure to install the (8) M5 x 16 mm mounting screws and washers to keep the receiver from falling. Do not fully tighten the screws. These will be tightened after alignment later.

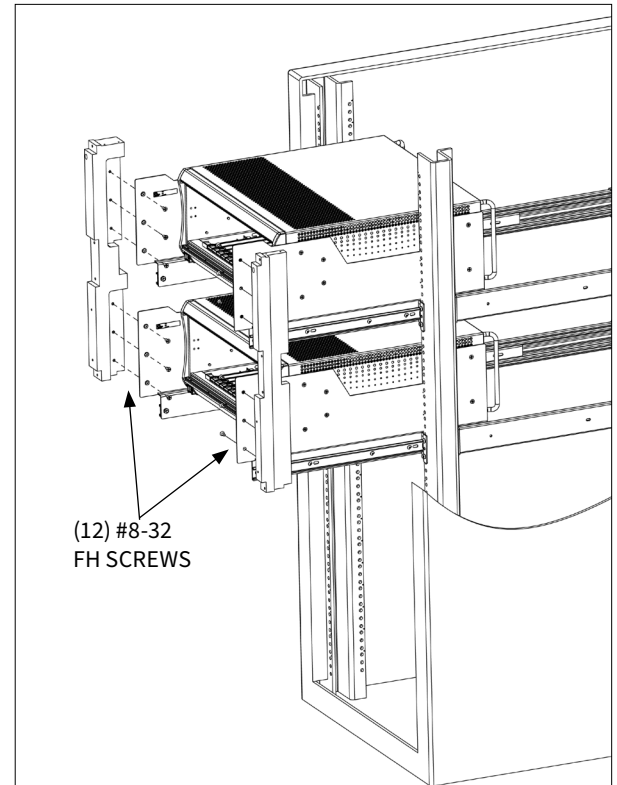

Figure G.

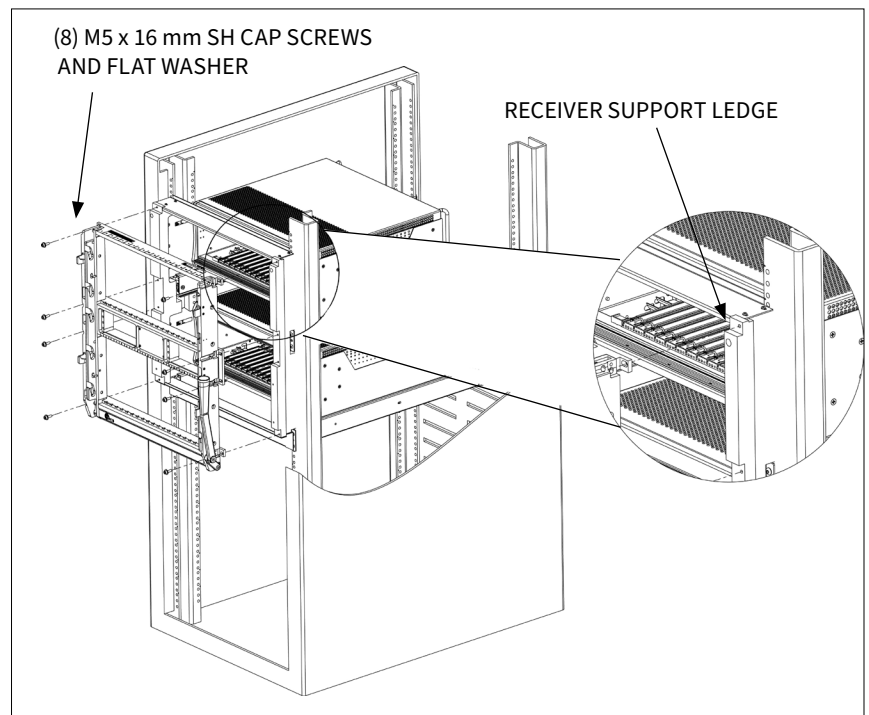

Figure H.

[RETURN TO INDEX](#)

G40X RECEIVER INSTALLATION (CONT'D)

PART # 310120163

RECEIVER ALIGNMENT

1. To align the receiver, install 4 interconnect adapters (**Figure I**) with instrument cards attached, in module positions 4 and 20 in both the upper and lower tiers.
2. Tighten the captive screws for each interconnect adapter, installing to the receiver frame (**Figure I**).
3. With the interconnect adapters in place, tighten the previously partially secured (8) M5 x 16 mm receiver mounting screws. The receiver is now aligned.
4. The interconnect adapters may now be uninstalled and moved to other slot locations, if needed.

SECURING ASSEMBLY TO INSTRUMENT RACK

1. After the receiver has been aligned and all screws have been tightened, slide the assembly back against the instrument rack mounting rails.
2. Insert the 10-32 x 2.0 long socket head cap screw into the counter-bored hole near the top of the left mounting rail and tighten into the instrument rack.
3. Repeat step #1 for the right mounting rail.

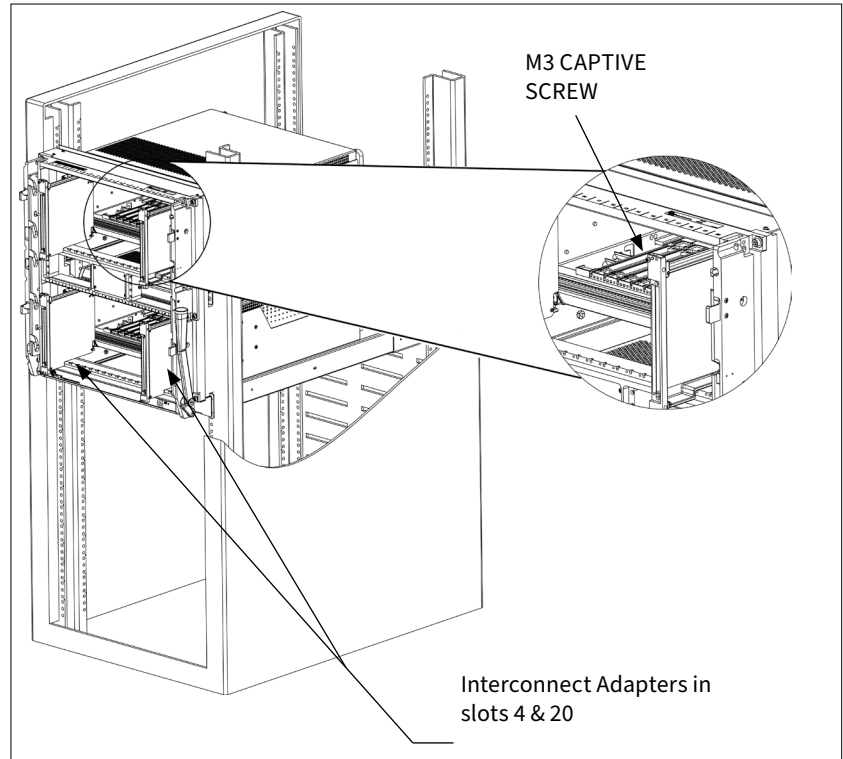

Figure I. Install interconnect adapters into slots 4 and 20 in each tier to align receiver.

[RETURN TO INDEX](#)

RECEIVER HANDLE REPOSITIONING AND REMOVAL

PART # 310120188, 310120186, 310120163

TOOLS REQUIRED

$\frac{3}{32}$ Allen Wrench

VERTICAL REPOSITIONING

For proper operation, the G20/G20x receiver handle requires approximately 90° of counter-clockwise vertical movement for engagement and 90° of clockwise vertical movement for disengagement of the ITA. Follow the steps below if repositioning of the handle is needed to allow for this vertical movement.

1. Remove the handle screw with a $\frac{3}{32}$ Allen wrench.
2. Remove the handle and reposition in 90° increments (**Figure A**).
3. Replace the screw and tighten until the handle is secured tightly.



REMOVAL AND ALTERNATING SIDES

The handle for the above listed part numbers can be used on either the left or right side of the receiver to accommodate different mounting configuration requirements. All handles are removable for storage or transportation purposes.

1. To remove the handle (and offset link), remove the handle screw with a $\frac{3}{32}$ Allen wrench (**Figure B**).
2. To reinstall handle on the alternate side, use the $\frac{3}{32}$ Allen wrench, to remove the screw and shaft cover on the alternate side of the receiver. Disassemble the handle from the offset link (**Figure B**).
3. Flip the offset link and reassemble with the handle. Reinstall the handle to the receiver at the preferred 90° position (**Figure C**).
4. Install the screw and shaft cover into the cavity on the side originally occupied by the handle. (**Figure C**).

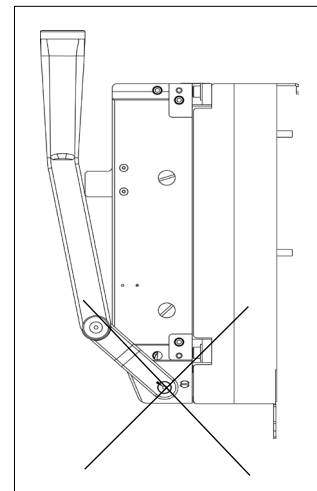

Figure A. Handle can be adjusted in 90 degree increments.

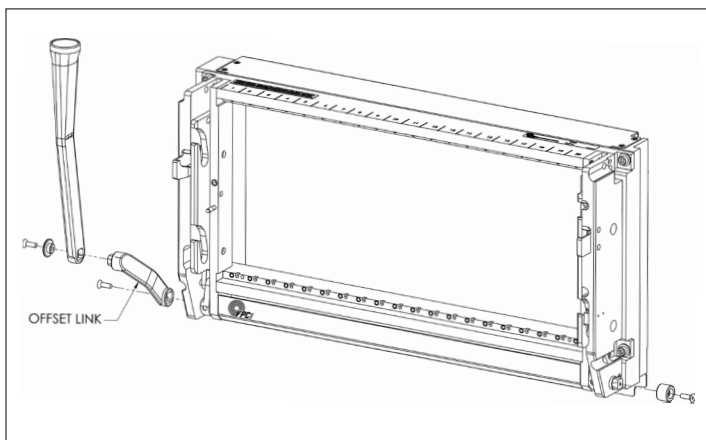

Figure C.

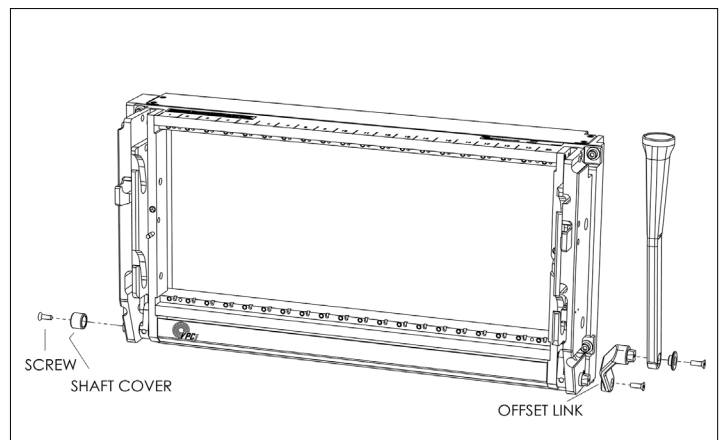

Figure B.

[RETURN TO INDEX](#)

MICROSWITCH REPLACEMENT

PART # 310113365, 310113692

A microswitch is included with VPC's Pull-Thru Receivers and is used to determine the presence (or absence) of an ITA engaged in the system. It is usually configured so that power to the interface is turned off when there is no ITA present. If the included microswitch needs to be replaced, follow the steps below.

TOOLS REQUIRED

Phillips Screwdriver

REMOVAL

1. Disengage the ITA from the receiver (remove the ITA completely).
2. With the receiver handle in the open position (handle down), unscrew the retaining screws using a Phillips screwdriver, removing each as they are loosened. Caution should be used to prevent screws from falling into the test system.
3. Carefully remove the microswitch.
4. For microswitch installation, repeat steps 1 - 3 in reverse order.



AS WITH ALL ELECTRICAL SYSTEMS - DISCONNECT ALL ELECTRICAL CONNECTIONS TO THE SYSTEM PRIOR TO MICROSWITCH REMOVAL OR INSTALLATION.

[RETURN TO INDEX](#)

ITA AND RECEIVER ENGAGEMENT

Prior to engaging an ITA with the receiver for the first time, ensure all modules (ITA and receiver) are properly installed. This involves inspection of modules to ensure proper mounting and to verify module positioning. Module positions are shown in **(Figure A)**. Modules must be installed so that Pin Position 1 of each respective mating receiver and ITA module pair are on opposing sides. VPC recommends that Pin Position 1 always be positioned to the left in the receiver and ITA frames. All modules to be installed properly.

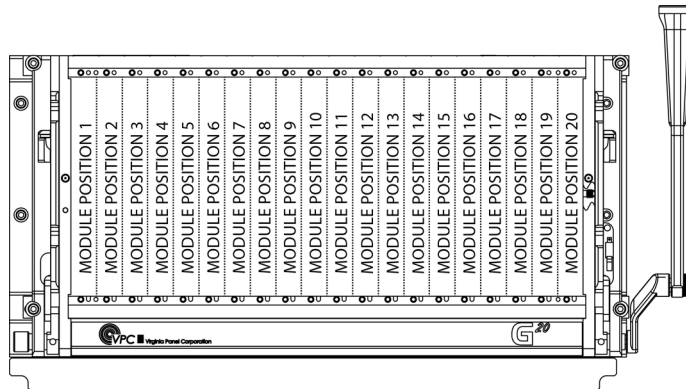

G20 Receiver Mating Side

Figure A. G20 Receiver and ITA.

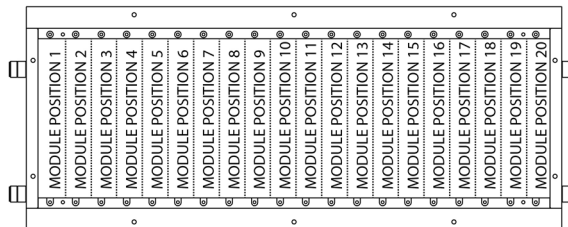

G20 ITA Wiring Side

1. The receiver should be checked for any foreign objects that may interfere with engagement.
2. After inspection, the ITA is ready for engagement with the receiver. The ITA may be placed onto the receiver platform and properly positioned relative to the receiver guide pins. Ensure that the ITA roller bearings are aligned with the receiver slide openings when the receiver handle is in the open position.
3. Carefully rotate the handle forward to actuate the receiver slide engagement mechanisms, which will draw the ITA into engagement position with the receiver. Once the handle reaches a positive stop at the end of its travel and latches into place, the modules are engaged.
4. Upon completing use of the ITA, rotate the receiver handle to the open position, remove the ITA, reinstall the receiver protective cover and rotate the handle to the closed position.
5. Always protect the contacts when the system is not in use. The receiver contacts are protected when either the ITA or receiver protective cover is engaged. VPC recommends use of both receiver and ITA protective covers to avoid potential contact damage.



IMPROPER INSTALLATION WILL DAMAGE THE MODULES, AND POSSIBLY THE ITA AND/OR RECEIVER.



FORCED ENGAGEMENT OF THE RECEIVER AND ITA WILL RESULT IN SERIOUS DAMAGE TO MULTIPLE PARTS OF THE SYSTEM (MODULES, RECEIVER, ITA AND CONTACTS) AND VOID ANY EXISTING PRODUCT WARRANTY.

[RETURN TO INDEX](#)

TROUBLESHOOTING

ITA and receiver will not mate/ force is required to mate ITA and receiver.

- ITA is out of alignment
- ITA Module is not paired with mating receiver module.
- Foreign objects or tools are blocking connection.
- Contact(s) is bent in either an ITA module or receiver module.
- Modules may not be installed with the correct orientation.

No continuity upon engagement.

- Contact is not fully seated in module or is bent.
- "Short" in wiring

ITA and receiver will not mate after troubleshooting the above.

- Contact VPC – unauthorized user adjustments or alterations to VPC equipment voids manufacturer's warranty.

Receiver and ITA will not disengage

- Engagement mechanism within the receiver may be faulty. Contact VPC immediately. -unauthorized user adjustments or alterations to VPC equipment voids manufacturer's warranty.

PRECAUTIONARY NOTES

The following precautionary notes are general standards of practice to follow for safety and to achieve optimum equipment performance.

- Always protect an interconnect system from potential damage caused by people or items making accidental contact with the receiver/ITA assembly, transport or movement, or installation and removal. Use protective covers for ITAs and receivers to protect contacts and modules.
- When using a contact insertion or extraction tool, always insert and extract this tool in vertical alignment with the contact. Never apply pressure to the side of the tool.
- Never probe a contact without using a mating patchcord as a test lead.
- Never forcefully engage an ITA and receiver.
- Dropping an ITA may cause misalignment and/or irreparable damage.
- Disconnect power to a test system prior to handling or performing maintenance.



FORCED ENGAGEMENT OF THE RECEIVER AND THE ITA WILL RESULT IN SERIOUS DAMAGE TO MULTIPLE PARTS OF THE SYSTEM (MODULES, RECEIVER, ITA AND CONTACTS) AND VOID ANY EXISTING PRODUCT WARRANTY.