



STRAIN RELIEF USER MANUAL

INDEX *(CLICK TO NAVIGATE TO PAGE)*

PAGE

2 [TECH TIP: WIRE SLACK](#)

3 [TECH TIP: ZIP-TIE GUN SETTINGS](#)

4 [INSTALLING ZIP-TIES](#)

STRAIN RELIEF ASSEMBLY FOR:

5 [90 SERIES MODULES](#)

6 [QUADRAPADDLE MODULES](#)

7 [HIGH FREQUENCY MODULES](#)

8 [FIBER OPTIC](#)

9 [ICON/I1 RECEIVERS](#)

10 [I2 MICRO ICON RECEIVERS](#)

11 [I2 MX RECEIVERS](#)

12 [90 SERIES SIM MODULES](#)

13 [DOCK D1 AND D3/D4 RECEIVERS WITH ICON MODULES](#)

Please note that any printed or downloaded user manual may not reflect the most current revision. The information contained herein is subject to change. For the most current information available, visit vpc.com.

TECH TIP: WIRE SLACK

Before installing strain relief, consider the following tips to ensure the best cable management technique. Proper strain relief is crucial for optimal performance. Should you have any questions during the installation process, feel free to [contact us](#).

1. Check for any strained wires before assembling a strain relief plate to a connector. A strained wire is tight and has no slack.
2. Wires must have slack between the module and the strain relief.

CORRECT

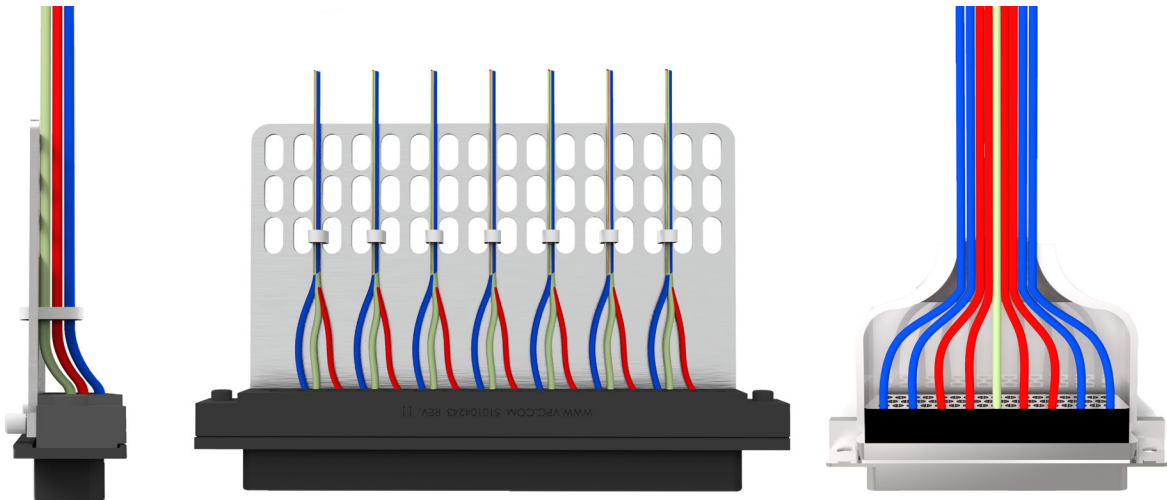

INCORRECT

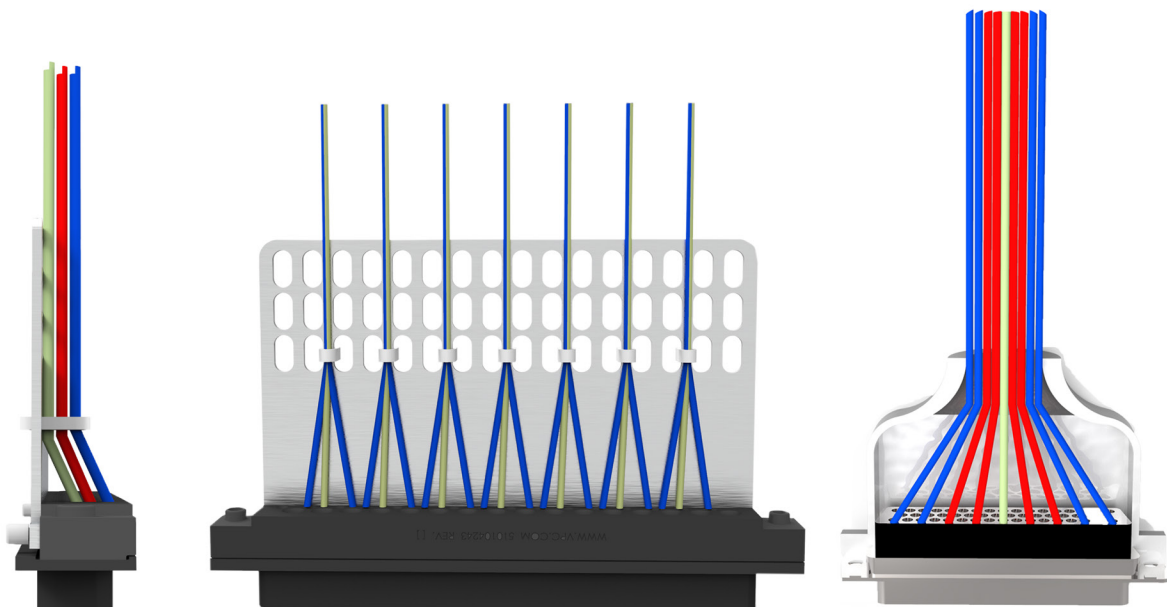

[RETURN TO INDEX](#)

TECH TIP: ZIP-TIE GUN SETTINGS

(EXAMPLE SHOWN: PANDUIT GTS CABLE TIE TOOL)

Zip-tie guns settings are determined by the size of the zip-ties used. Below are proper settings for a Panduit GTS Cable Tie Tool based on various sizes of zip-ties.

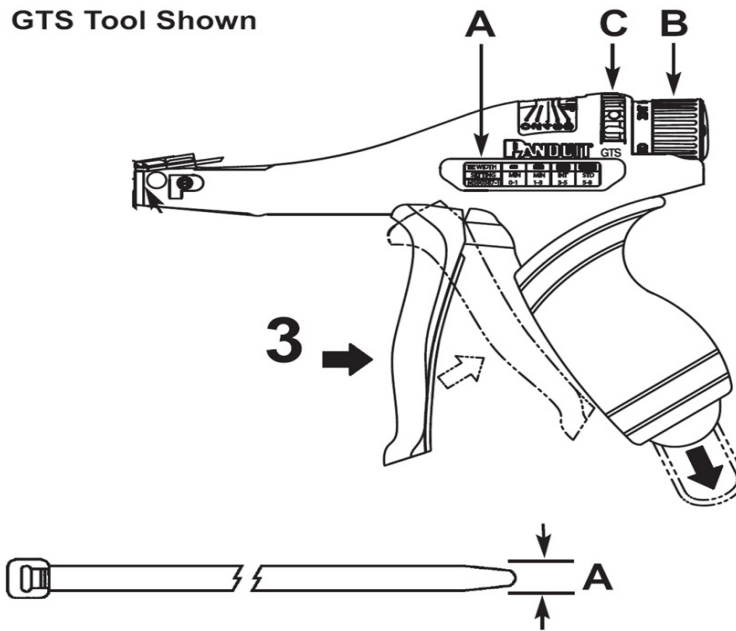

<p>A</p>	<p>SUBMIN .070" (1.8mm)</p>	<p>MIN .098" (2.5mm)</p>	<p>INT .142" (3.6mm)</p>	<p>STD .190" (4.8mm)</p>
<p>B</p>				
<p>C</p>	<p>0 - 1</p>	<p>1 - 3</p>	<p>3 - 5</p>	<p>5 - 8</p>

[RETURN TO INDEX](#)

INSTALLING ZIP-TIES



NOTE: DO NOT USE ZIP-TIES OR TWIST LOCKS FOR FIBER OPTIC OR OTHER HIGH FREQUENCY WIRES. VPC RECOMMENDS THE USE OF VELCRO TO PREVENT WIRE DAMAGE. SEE PAGE 7 OF THIS USER MANUAL FOR MORE INFORMATION ON HOW TO USE STRAIN RELIEF WITH FIBER OPTIC AND OTHER HIGH FREQUENCY WIRES.

1. A wire run is grouped with adjacent wire runs to form a zip-tie bundle. This zip-tie bundle is then zip-tied to the space on the strain relief aligned with the plugged holes where the wires exit the module. Use the equation below to calculate the recommended number of wires per zip-tie.

$$\text{Total \# Wires} \div \text{\# Strain Relief Spaces (Figure A)} = \text{\# Wires per Zip-Tie Bundle}$$

2. Use 2 zip-ties vertically, per bundle, to prevent wires from pivoting (Figure B).
3. All wires in one wire group will be zip-tied in the same bundle.
4. There should be slack in the wire between the contact and the zip-tie.
5. Zip-ties must be cut flush to the zip-tie head.
6. All zip-tie heads on a strain relief plate must lie in the same direction and orientation.
7. Zip-ties must be tight enough to keep the wires from moving up and down or back and forth, but not be overly tight as to prevent some slack. If the wires can be moved between the zip-tie and the contact, then the contact does not have proper strain relief. Another zip-tie needs to be added in vertical alignment.

NOTE: Do not zip-tie bundles to the edges of the strain relief plate.

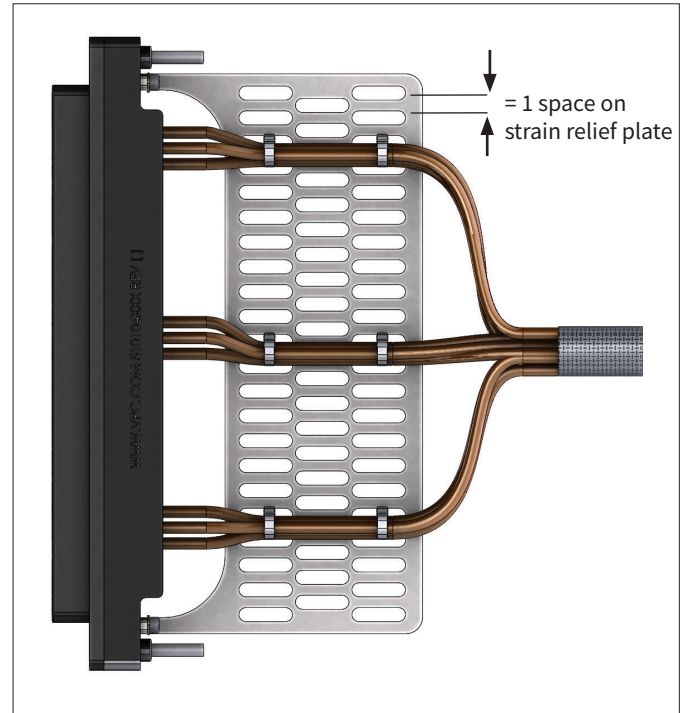

Figure A

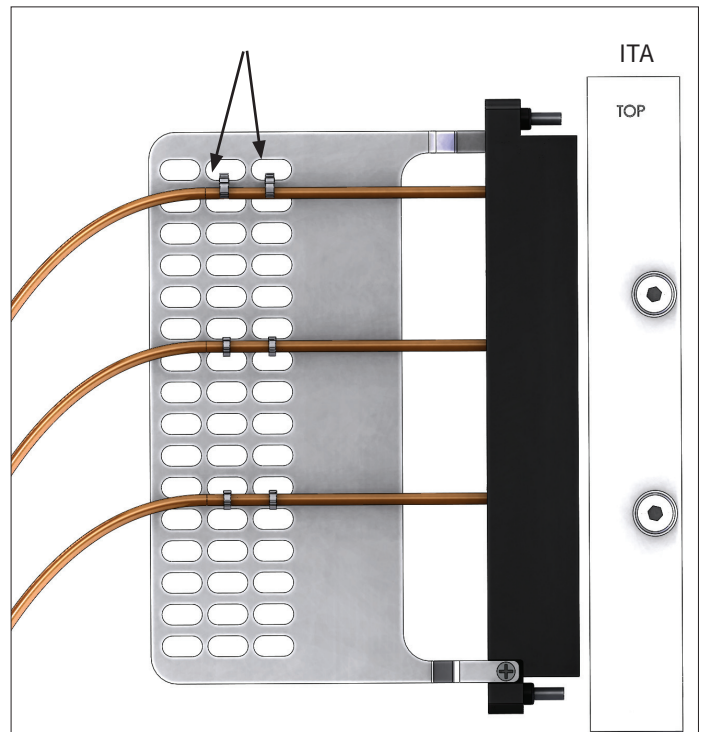

Figure B

[RETURN TO INDEX](#)

90 SERIES MODULE STRAIN RELIEF ASSEMBLY

STRAIN RELIEF PART # 510109116
FOR USE WITH MODULE PART #'S 510104102, -120, -123, -133, -134, -136, -149, -206, -243, - 261

TOOLS REQUIRED

Zip-Tie Gun
Torque Screw Driver

1. Replace any wire that is too short and causing strain to the crimp area.
2. Place the strain relief plate against the module so it rests on the module ledge. Insert the screws to hold the strain relief plate.
3. Torque the strain relief plate screws to the values given in the table below.
4. Attach wires to the strain relief plate using the best method based on the wire type. Use velcro versus zip-ties, for fiber optic wire or other high frequency wire.



Figure A.

Figure B. Torque Values diagram

Module Breakout		
Strain Relief	Module	Torque Spec
510109116	510104102	4 in-lb
	510104120	
	510104123	
	510104133	
	510104134	
	510104136	3 ½ in-lb
	510104149	
	510104206	
	510104243	
	510104261	

[RETURN TO INDEX](#)

QUADRAPADDLE MODULE STRAIN RELIEF ASSEMBLY

PART # 510109348, 510109349
FOR USE WITH MODULE PART # 510150115, - 116, -130, -131

TOOLS REQUIRED

Zip-Tie Gun
Torque Screw Driver

1. Replace any wire that is too short and causing the wire to strain in the crimp area.
2. Separate the 2 base pieces of the strain relief plate. Place the smaller of the plates against a module side. Each plate has a groove that fits into a strip on the side of the module (**Figure B**).
3. Be sure that the wires exit in the direction of the strain relief plate.
4. Place the opposite strain relief plate on the other side of the module.
5. Align the screw holes with the standoffs between the two plates. Screw the two plates together with the supplied screws.
6. Make sure no wires get pinched between the two plates.
7. Torque to 2-½ in-lbs.
8. Attach wires to the strain relief plate using the best method based on the wire type. Use velcro versus zip-ties, for fiber optic wire or other high frequency wire. See instructions on page 4 for properly installing zip-ties.

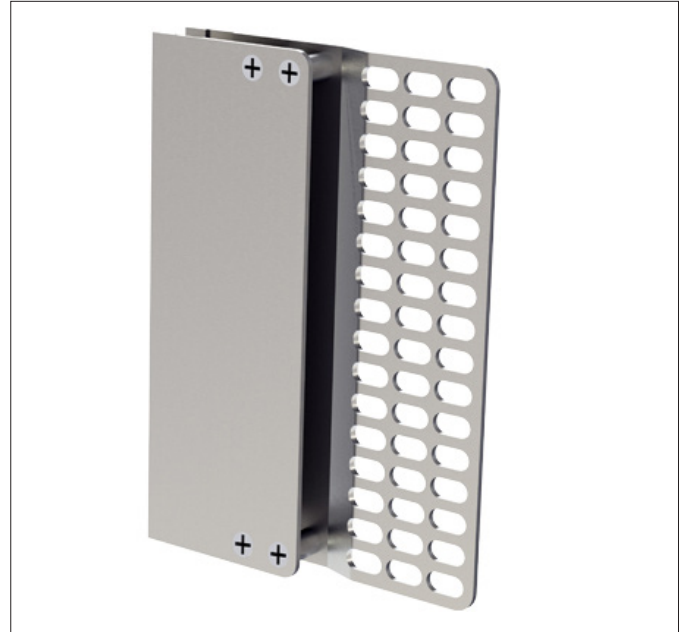

Figure A. Strain Relief part # 510109349

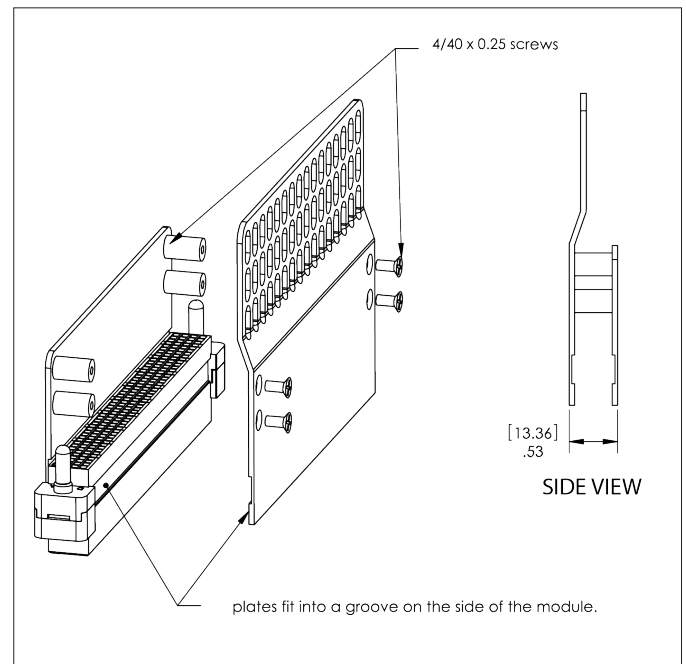

Figure B.

[RETURN TO INDEX](#)

HIGH FREQUENCY MODULE STRAIN RELIEF ASSEMBLY

PART # 510109116,-282,-296, -298, -475, -548



NOTE: DO NOT USE ZIP-TIES OR TWIST LOCKS ON HIGH FREQUENCY WIRE. VPC RECOMMENDS THE USE OF VELCRO. ZIP-TIES OR TWIST LOCKS ON HIGH FREQUENCY WIRE, ESPECIALLY WITH TOO MUCH TENSION APPLIED, WILL PINCH THE WIRE. OVERTIGHTENED APPLICATION TO STRAIN RELIEF ON HIGH FREQUENCY WIRE (ANY WIRE TERMINATED TO VTAC, COAX, OR FIBER OPTIC) CAN DAMAGE THE WIRE.

TOOLS REQUIRED

Torque Screw Driver

STRAIN RELIEF GUIDELINES

1. Always ensure that the bend radius is larger than the minimum bend radius, for high frequency wires.
Minimum bend radius by wire type:

Min. Bend for RG-316: 0.6" [15.2 mm]
Min. Bend for RG-178: 0.4" [10.16mm]
Min. Bend for Flex 402: 0.5" [12.5 mm]
Min. Bend for Flex 405: 0.25"[6.35 mm]
2. Place the strain relief plate against the module so it rests on the module ledge. Wires for fully loaded modules, will need to be staggered over the strain relief.

NOTE: The receiver frame is installed between the strain relief plate and module for part # 510109298 (Figure B).

3. Torque the strain relief screws to 3 ½ in-lbs.
4. Use velcro to properly strain relieve the high frequency wires.



Figure A. Part # 510109475

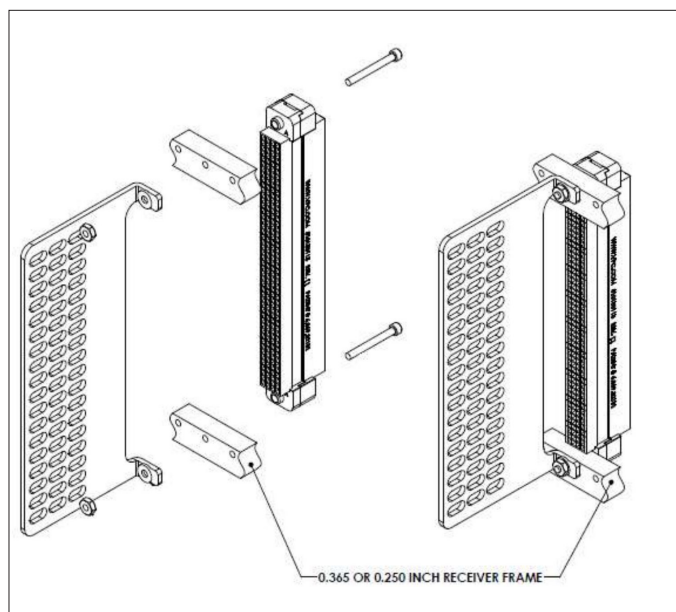

Figure B. 90 Series module strain relief, part # 510109298

[RETURN TO INDEX](#)

FIBER OPTIC STRAIN RELIEF ASSEMBLY

PART # 510109116, -296, -298

STRAIN RELIEF GUIDELINES

- Minimum bend radius of fiber optic wire:
 Min. Bend Radius= 15 X Diameter of Wire (**Figure A**)
 Min. Bend - 62.5/125 μ Multimode= 1.77" [45 mm]
 Min. Bend- POF= 1.18" [30 mm]
- For receiver side wires, leave a slight amount of slack in the cable when securing to the strain relief plate to allow the contacts to align when the modules are engaged (**Figure B**).



WHEN HANDLING FIBER OPTIC CABLES DO NOT LOOK INTO THE ENDS OF ANY CONNECTOR. LASER LIGHT COULD CAUSE PERMANENT EYE DAMAGE.

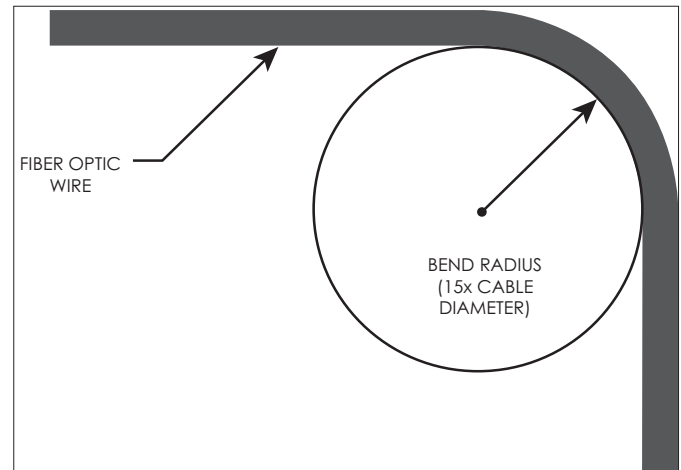

Figure A. Min. Bend Radius = 15 x Wire Diameter

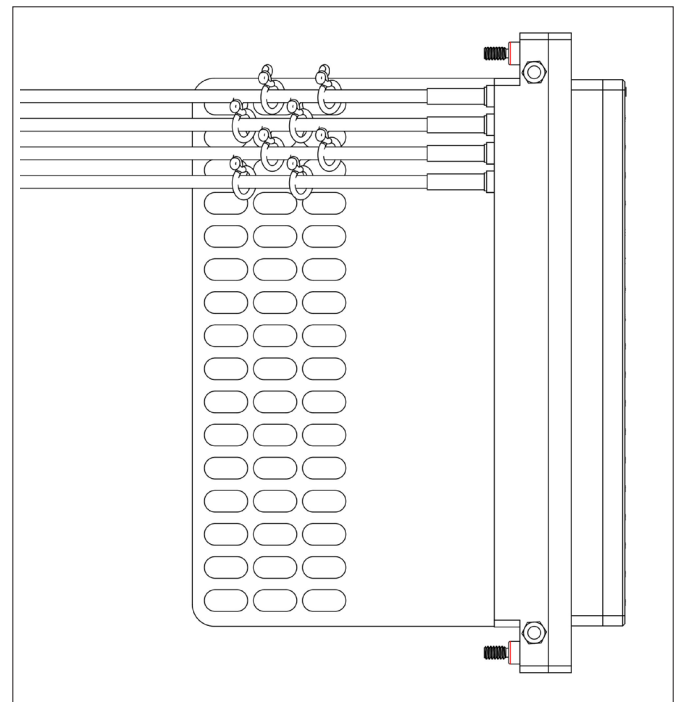

Figure B.

[RETURN TO INDEX](#)

iCON AND i1 RECEIVER STRAIN RELIEF ASSEMBLY

PART # 310113456, 310113531

TOOLS REQUIRED

Zip-Tie Gun
Phillips Head Screwdriver

iCon

1. Install the strain relief to the iCon receiver on the wiring side of the receiver frame (Figure A).
2. Fasten the strain relief to the iCon receiver frame with the included screws and a Phillips head screwdriver. Wires should be restrained a minimum of 2" from the wiring face of the module.
3. Attach wires to the strain relief plate using the best method based on the wire type. Use velcro versus zip-ties, for fiber optic wire or other high frequency wire. See instructions on page 4 for properly installing zip-ties.

NOTE: If using 8 AWG, 10 AWG, or non-flexible coax wire in the modules' center positions, the iCon strain relief stand-off kit, part # 310113582, is required.

NOTE: When assembling the strain relief using the stand-off kit, install all patchcords in the module before attaching strain relief.

i1

1. Using a Phillips head screwdriver, fasten the strain relief to the back (wiring) side of the i1 receiver with the 2-56 screws and nuts provided (Figure B). Place the nuts in the keying positions from the front side of the receiver.
2. Torque screws to 2 in-lbs [0.23 Nm]. If using the keying features, replace the 2-56 nuts with the keying pins (Figure C) and use the longer screws that come with the strain relief kit.

NOTE: If using 8AWG or 10AWG wire, the iCon strain relief kit, part # 310113582, will be required. Install patchcords into module before attaching strain relief.



Figure A. iCon

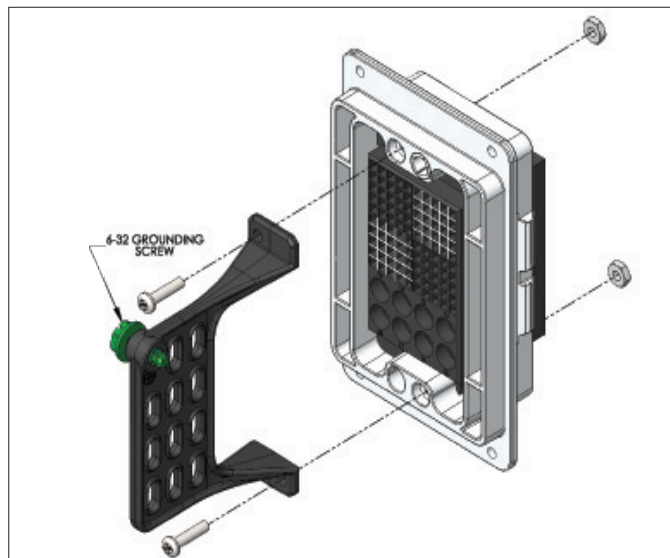

Figure B. i1 receiver strain relief.

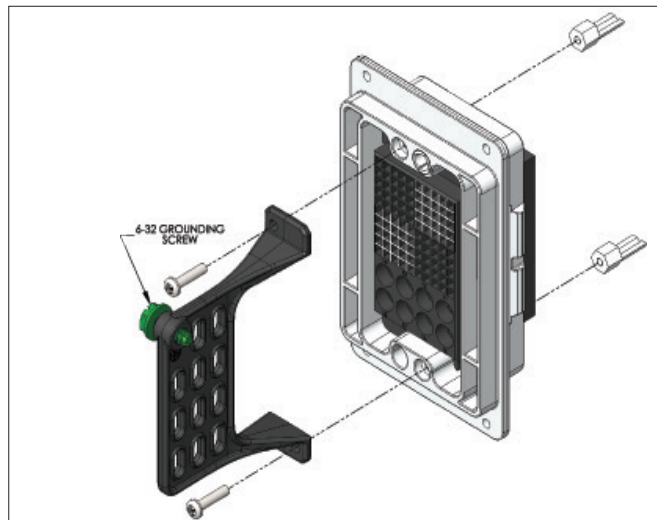

Figure C.

[RETURN TO INDEX](#)

i2 MICRO iCON RECEIVER STRAIN RELIEF ASSEMBLY

PART # 310113559

TOOLS REQUIRED

Zip-Tie Gun

Phillips Head Screwdriver

1. Using a Phillips head screwdriver, fasten the strain relief to the back (wiring) side of the i2 Micro iCon receiver with the 2-56 screws and nuts provided (**Figure A**). Place the nuts in the keying positions from the front side of the receiver.
2. Torque screws to 2 in-lbs [0.23 Nm] (**Figure B**). If using the keying features, replace the 2-56 nuts with the keying pins.

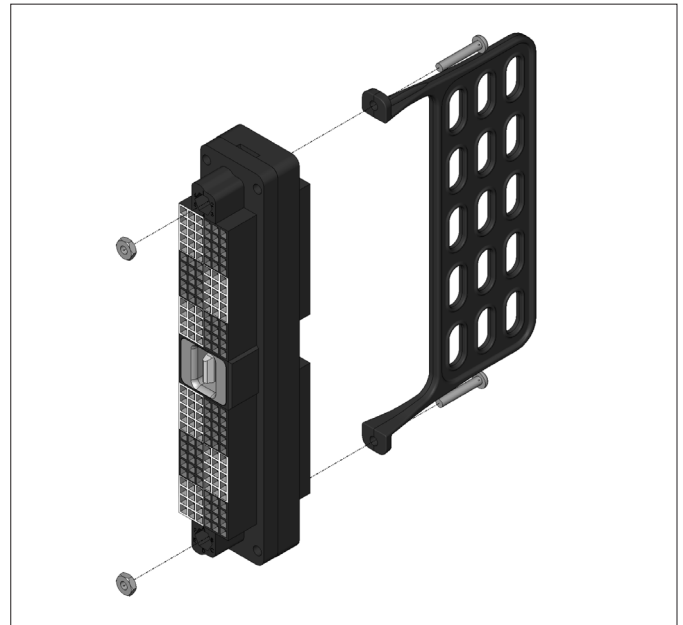

Figure A.

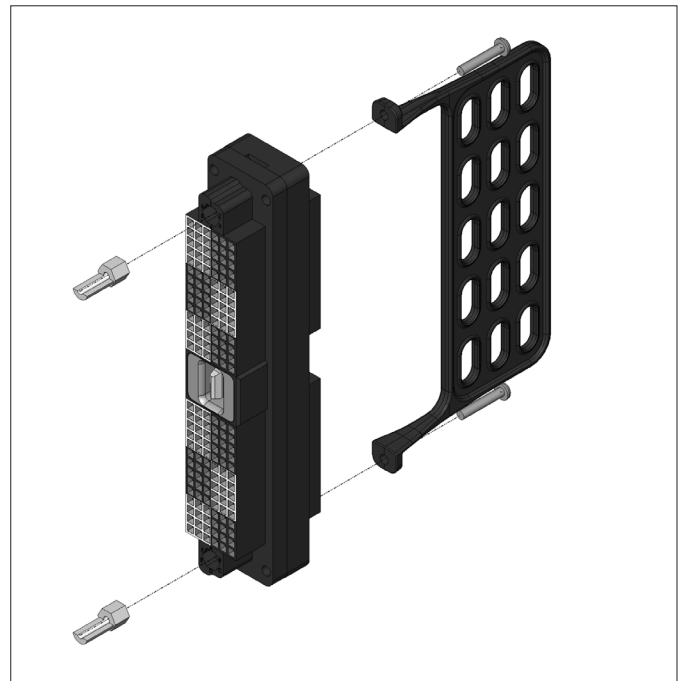

Figure B. Strain relief with keying pins.

[RETURN TO INDEX](#)

i2 MX RECEIVER STRAIN RELIEF ASSEMBLY

PART # 310113681

TOOLS REQUIRED

Zip-Tie Gun

Phillips Head Screwdriver

1. Using the Phillips head screwdriver, fasten the strain relief to the back (wiring) side of the i2 MX receiver with the 2-56 screws and nuts provided (**Figure A**). Place the nuts in the keying positions from the front side of the receiver.
2. Torque screws to 3.5 in-lbs [0.4 Nm] strain relief and 3.5 in-lbs [0.4 Nm] keying. If using the keying features, replace the 2-56 nuts with the keying pins (**Figure B**).

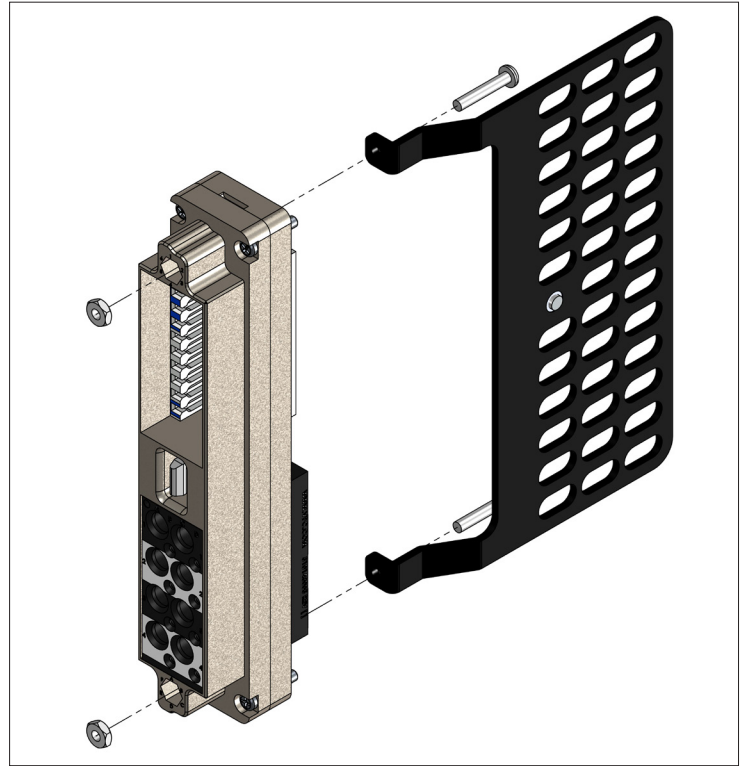

Figure A.

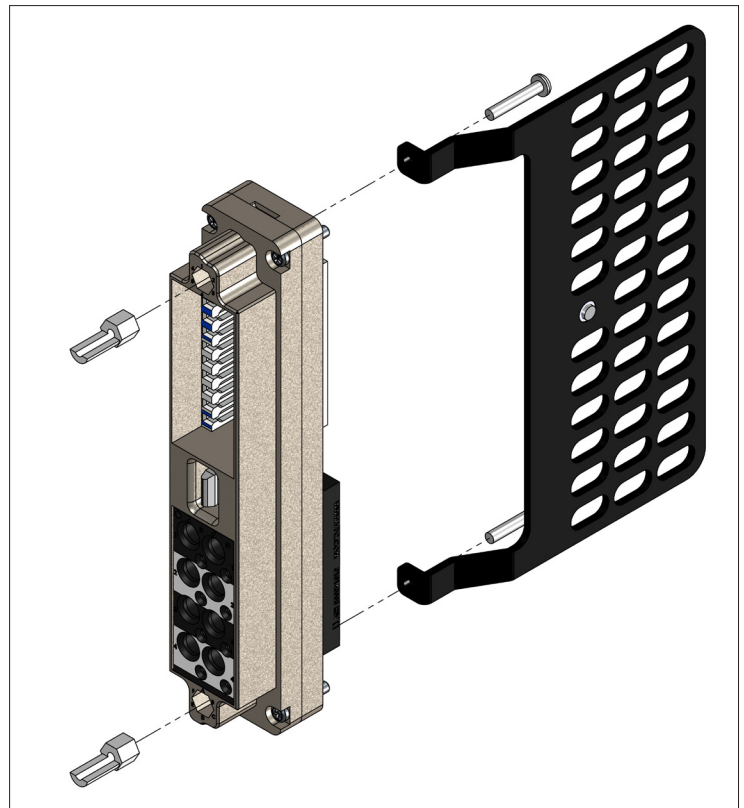

Figure B. i2 MX receiver strain relief with keying pins.

[RETURN TO INDEX](#)

90 SERIES SIM MODULE RECEIVER STRAIN RELIEF ASSEMBLY

PART # 510109568

TOOLS REQUIRED

Zip-Tie Gun
Phillips Head Screwdriver

1. Using the Phillips head screwdriver, fasten the strain relief to the rear (wiring) side of the 90 Series SIM module with the 2-56 screws provided (**Figure A**).
2. Torque screws to 2 in-lbs [0.23 Nm].
3. Secure wires with zip-ties included with strain relief for restraining wires. Follow zip-tie guidelines provided earlier in this manual.

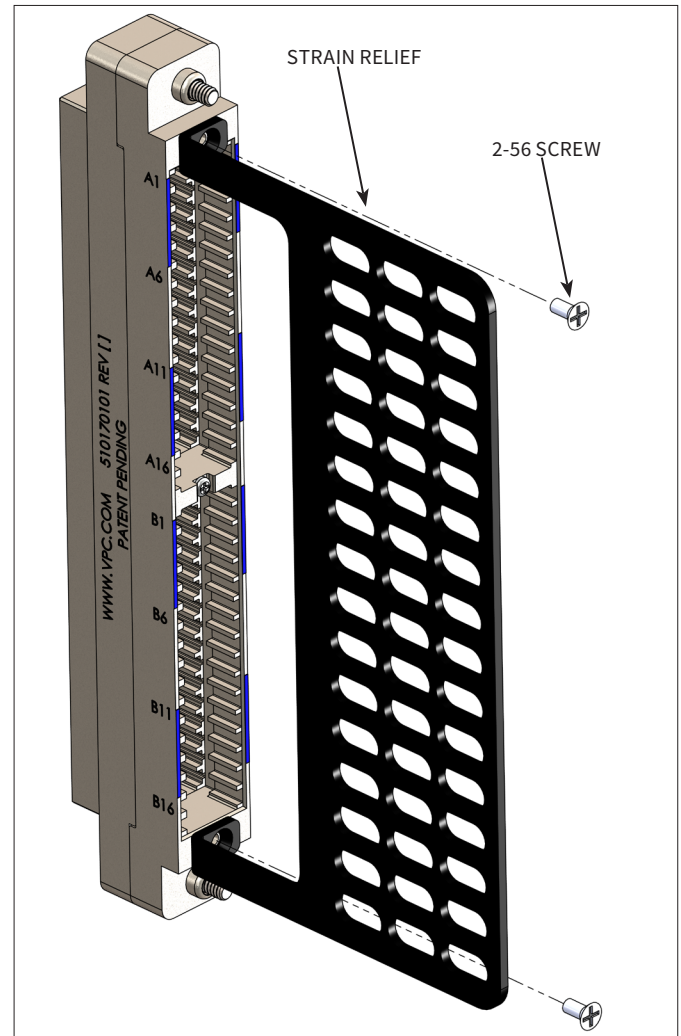

Figure A.

[RETURN TO INDEX](#)

iDOCK RECEIVER STRAIN RELIEF ASSEMBLY

D1 PART # 310131102
 D3/D4 PART # 310131101
 STRAIN RELIEF (iCON) # 310113531

TOOLS REQUIRED

Zip-Tie Gun
 Phillips Head Screwdriver

D1

1. Using a Phillips head screwdriver, fasten the strain relief to the back (wiring) side of the D1 receiver with the 2-56 screws and nuts provided (**Figure A**). Place the nuts in the keying positions from the front side of the receiver.
2. Torque screws to 2 in-lbs [0.23 Nm].

NOTE: If using 8 AWG or 10 AWG wire, the iCon strain relief stand off kit, part # 310113582, will be required. Install patchcords into module before attaching strain relief.

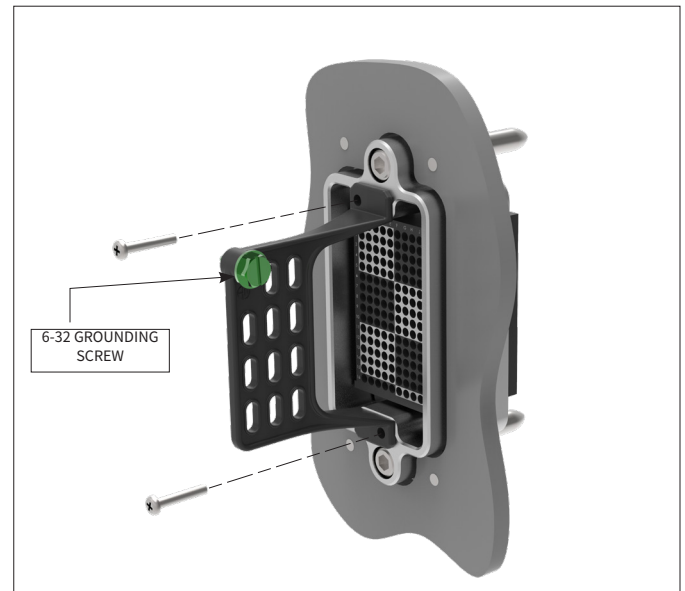

Figure A. D1

D3/D4 WITH ICON MODULE

1. Using a Phillips head screwdriver, fasten the strain relief to the back (wiring) side of the D3/D4 receiver with the two 2-56 screws provided (**Figure B**).
2. Torque screws to 2 in-lbs [0.23 Nm].

NOTE: Two 2-56 nuts are included with the strain relief plate; however, they are not required for this application. The screws will enter the tapped mounting screw holes, instead.

NOTE: If using 8 AWG or 10 AWG wire, the iCon strain relief stand off kit, part # 310113582, will be required. Install patchcords into module before attaching strain relief.

NOTE: The strain reliefs for iCon modules will fasten directly to the receiver and not to the module.

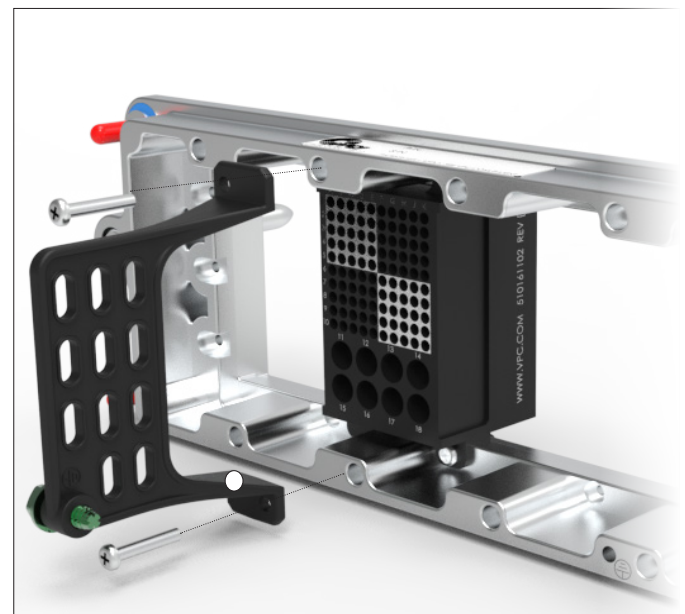

Figure B. D3/D4 with iCon module

[RETURN TO INDEX](#)