

4

3

2

1

DO NOT SCALE DRAWING

THE INFORMATION CONTAINED HEREIN IS THE EXCLUSIVE PROPERTY OF VIRGINIA PANEL CORPORATION AND IS SUBMITTED FOR USE BY THE CUSTOMER ONLY. THE DATA SHALL NOT BE DUPLICATED, USED, OR DISCLOSED IN WHOLE OR IN PART FOR ANY PURPOSE OTHER THAN TO MAINTAIN THE EQUIPMENT PROVIDED. CONSULT WITH VIRGINIA PANEL CORPORATION ENGINEERING IF MORE DETAIL IS REQUIRED.

REVISIONS

| REV | DESCRIPTION | DATE | ENGR |
|-----|-------------|---------|------|
| F | ECN # 5325 | 6/13/14 | LL |

D
C
B
A

D
C
B
A

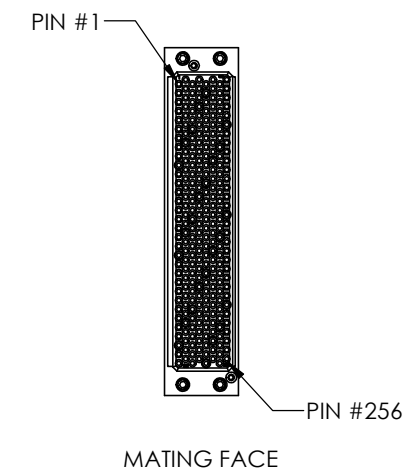
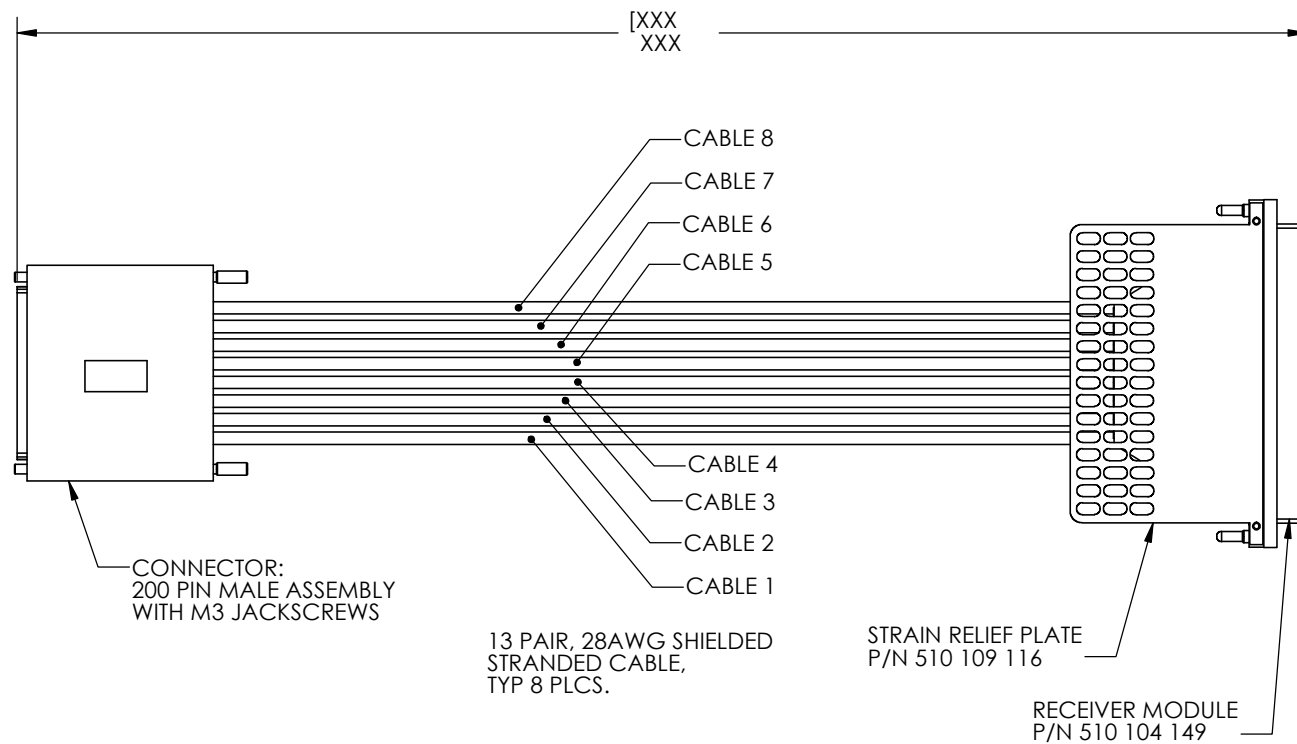
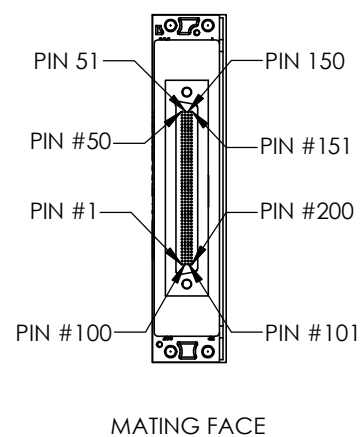

| | | | |
|--|-----------|----------------------|--------------|
| CUSTOMER DRAWING | | | |
| VPC | | | |
| CBA, RCV, TRIPADDLE TO 200-PIN ML LFH W/ M3 JACKSCREWS | | | |
| SIZE | CAGE CODE | DWG. NO. | REV |
| C | 18117 | 540105020X05 | F |
| SCALE: NONE | | 540105020105 2/18/03 | SHEET 1 OF 2 |

| | |
|------------------|-----------------------|
| MATING MODULE | 510108131 (1) |
| MATING PATCHCORD | 7-103424000-020 (100) |

DIMENSIONS ARE SHOWN AS:
[MILLIMETERS]
INCHES

4

3

2

1

| MOLEX 200 PIN CONNECTOR CABLE 1 | | | COLOR CODE | VPC MODULE 510104149 | MOLEX 200 PIN CONNECTOR CABLE 2 | | | COLOR CODE | VPC MODULE 510104149 | MOLEX 200 PIN CONNECTOR CABLE 3 | | | COLOR CODE | VPC MODULE 510104149 | MOLEX 200 PIN CONNECTOR CABLE 4 | | | COLOR CODE | VPC MODULE 510104149 |
|---------------------------------|--------------|---------|------------|----------------------|---------------------------------|---------|-----|------------|----------------------|---------------------------------|-----|-----|--------------|----------------------|---------------------------------|--|--|------------|----------------------|
| 1 | TWISTED PAIR | WHT/PNK | 21 | 14 | TWISTED PAIR | WHT/PNK | 14 | 27 | TWISTED PAIR | WHT/PNK | 8 | 40 | TWISTED PAIR | WHT/PNK | 195 | | | | |
| 100 | | PNK/WHT | 53 | 87 | | PNK/WHT | 46 | 74 | | PNK/WHT | 40 | 61 | | PNK/WHT | 227 | | | | |
| 2 | TWISTED PAIR | WHT/BRN | 22 | 15 | TWISTED PAIR | WHT/BRN | 15 | 28 | TWISTED PAIR | WHT/BRN | 9 | 41 | TWISTED PAIR | WHT/BRN | 194 | | | | |
| 99 | | BRN/WHT | 54 | 86 | | BRN/WHT | 47 | 73 | | BRN/WHT | 41 | 60 | | BRN/WHT | 226 | | | | |
| 3 | TWISTED PAIR | WHT/BLU | 23 | 16 | TWISTED PAIR | WHT/BLU | 16 | 29 | TWISTED PAIR | WHT/BLU | 10 | 42 | TWISTED PAIR | WHT/BLU | 193 | | | | |
| 98 | | BLU/WHT | 55 | 85 | | BLU/WHT | 48 | 72 | | BLU/WHT | 42 | 59 | | BLU/WHT | 225 | | | | |
| 4 | TWISTED PAIR | WHT/VIO | 85 | 17 | TWISTED PAIR | WHT/VIO | 17 | 30 | TWISTED PAIR | WHT/VIO | 72 | 43 | TWISTED PAIR | WHT/VIO | 131 | | | | |
| 97 | | VIO/WHT | 117 | 84 | | VIO/WHT | 49 | 71 | | VIO/WHT | 104 | 58 | | VIO/WHT | 163 | | | | |
| 5 | TWISTED PAIR | WHT/GRN | 86 | 18 | TWISTED PAIR | WHT/GRN | 78 | 31 | TWISTED PAIR | WHT/GRN | 73 | 44 | TWISTED PAIR | WHT/GRN | 130 | | | | |
| 96 | | GRN/WHT | 118 | 83 | | GRN/WHT | 110 | 70 | | GRN/WHT | 105 | 57 | | GRN/WHT | 162 | | | | |
| 6 | TWISTED PAIR | WHT/GRY | 87 | 19 | TWISTED PAIR | WHT/GRY | 79 | 32 | TWISTED PAIR | WHT/GRY | 74 | 45 | TWISTED PAIR | WHT/GRY | 129 | | | | |
| 95 | | GRY/WHT | 119 | 82 | | GRY/WHT | 111 | 69 | | GRY/WHT | 106 | 56 | | GRY/WHT | 161 | | | | |
| 7 | TWISTED PAIR | WHT/TAN | 148 | 20 | TWISTED PAIR | WHT/TAN | 80 | 33 | TWISTED PAIR | WHT/TAN | 135 | 46 | TWISTED PAIR | WHT/TAN | 67 | | | | |
| 94 | | TAN/WHT | 180 | 81 | | TAN/WHT | 112 | 68 | | TAN/WHT | 167 | 55 | | TAN/WHT | 99 | | | | |
| 8 | TWISTED PAIR | WHT/ORG | 149 | 21 | TWISTED PAIR | WHT/ORG | 142 | 34 | TWISTED PAIR | WHT/ORG | 136 | 47 | TWISTED PAIR | WHT/ORG | 66 | | | | |
| 93 | | ORG/WHT | 181 | 80 | | ORG/WHT | 174 | 67 | | ORG/WHT | 168 | 54 | | ORG/WHT | 98 | | | | |
| 9 | TWISTED PAIR | WHT/YEL | 150 | 22 | TWISTED PAIR | WHT/YEL | 143 | 35 | TWISTED PAIR | WHT/YEL | 137 | 48 | TWISTED PAIR | WHT/YEL | 65 | | | | |
| 92 | | YEL/WHT | 182 | 79 | | YEL/WHT | 175 | 66 | | YEL/WHT | 169 | 53 | | YEL/WHT | 97 | | | | |
| 10 | TWISTED PAIR | TAN/PNK | 151 | 23 | TWISTED PAIR | TAN/PNK | 144 | 36 | TWISTED PAIR | TAN/PNK | 138 | 49 | TWISTED PAIR | TAN/PNK | 4 | | | | |
| 91 | | PNK/TAN | 183 | 78 | | PNK/TAN | 176 | 65 | | PNK/TAN | 170 | 52 | | PNK/TAN | 36 | | | | |
| 11 | TWISTED PAIR | TAN/BRN | 212 | 24 | TWISTED PAIR | TAN/BRN | 206 | 37 | TWISTED PAIR | TAN/BRN | 199 | 50 | TWISTED PAIR | TAN/BRN | 3 | | | | |
| 90 | | BRN/TAN | 244 | 77 | | BRN/TAN | 238 | 64 | | BRN/TAN | 231 | 51 | | BRN/TAN | 35 | | | | |
| 12 | TWISTED PAIR | TAN/ORG | 213 | 25 | TWISTED PAIR | TAN/ORG | 207 | 38 | TWISTED PAIR | TAN/ORG | 200 | 150 | TWISTED PAIR | TAN/ORG | 2 | | | | |
| 89 | | ORG/TAN | 245 | 76 | | ORG/TAN | 239 | 63 | | ORG/TAN | 232 | 151 | | ORG/TAN | 34 | | | | |
| 13 | TWISTED PAIR | TAN/YEL | 214 | 26 | TWISTED PAIR | TAN/YEL | 208 | 39 | TWISTED PAIR | TAN/YEL | 201 | 149 | TWISTED PAIR | TAN/YEL | 1 | | | | |
| 88 | | YEL/TAN | 246 | 75 | | YEL/TAN | 240 | 62 | | YEL/TAN | 233 | 152 | | YEL/TAN | 33 | | | | |

| MOLEX 200 PIN CONNECTOR CABLE 5 | | | COLOR CODE | VPC MODULE 51010414 | MOLEX 200 PIN CONNECTOR CABLE 6 | | | COLOR CODE | VPC MODULE 510104149 | MOLEX 200 PIN CONNECTOR CABLE 7 | | | COLOR CODE | VPC MODULE 510104149 | MOLEX 200 PIN CONNECTOR CABLE 8 | | | COLOR CODE | VPC MODULE 510104149 |
|---------------------------------|--------------|---------|------------|---------------------|---------------------------------|---------|-----|------------|----------------------|---------------------------------|-----|-----|--------------|----------------------|---------------------------------|--|--|------------|----------------------|
| 148 | TWISTED PAIR | WHT/PNK | 5 | 135 | TWISTED PAIR | WHT/PNK | 11 | 122 | TWISTED PAIR | WHT/PNK | 18 | 109 | TWISTED PAIR | WHT/PNK | 24 | | | | |
| 153 | | PNK/WHT | 37 | 166 | | PNK/WHT | 43 | 179 | | PNK/WHT | 50 | 192 | | PNK/WHT | 56 | | | | |
| 147 | TWISTED PAIR | WHT/BRN | 6 | 134 | TWISTED PAIR | WHT/BRN | 12 | 121 | TWISTED PAIR | WHT/BRN | 19 | 108 | TWISTED PAIR | WHT/BRN | 25 | | | | |
| 154 | | BRN/WHT | 38 | 167 | | BRN/WHT | 44 | 180 | | BRN/WHT | 51 | 193 | | BRN/WHT | 57 | | | | |
| 146 | TWISTED PAIR | WHT/BLU | 7 | 133 | TWISTED PAIR | WHT/BLU | 13 | 120 | TWISTED PAIR | WHT/BLU | 20 | 107 | TWISTED PAIR | WHT/BLU | 88 | | | | |
| 155 | | BLU/WHT | 39 | 168 | | BLU/WHT | 45 | 181 | | BLU/WHT | 52 | 194 | | BLU/WHT | 120 | | | | |
| 145 | TWISTED PAIR | WHT/VIO | 68 | 132 | TWISTED PAIR | WHT/VIO | 75 | 119 | TWISTED PAIR | WHT/VIO | 81 | 106 | TWISTED PAIR | WHT/VIO | 89 | | | | |
| 156 | | VIO/WHT | 100 | 169 | | VIO/WHT | 107 | 182 | | VIO/WHT | 113 | 195 | | VIO/WHT | 121 | | | | |
| 144 | TWISTED PAIR | WHT/GRN | 69 | 131 | TWISTED PAIR | WHT/GRN | 76 | 118 | TWISTED PAIR | WHT/GRN | 82 | 105 | TWISTED PAIR | WHT/GRN | 152 | | | | |
| 157 | | GRN/WHT | 101 | 170 | | GRN/WHT | 108 | 183 | | GRN/WHT | 114 | 196 | | GRN/WHT | 184 | | | | |
| 143 | TWISTED PAIR | WHT/GRY | 70 | 130 | TWISTED PAIR | WHT/GRY | 77 | 117 | TWISTED PAIR | WHT/GRY | 83 | 104 | TWISTED PAIR | WHT/GRY | 153 | | | | |
| 158 | | GRY/WHT | 102 | 171 | | GRY/WHT | 109 | 184 | | GRY/WHT | 115 | 197 | | GRY/WHT | 185 | | | | |
| 142 | TWISTED PAIR | WHT/TAN | 71 | 129 | TWISTED PAIR | WHT/TAN | 139 | 116 | TWISTED PAIR | WHT/TAN | 84 | 103 | TWISTED PAIR | WHT/TAN | 215 | | | | |
| 159 | | TAN/WHT | 103 | 172 | | TAN/WHT | 171 | 185 | | TAN/WHT | 116 | 198 | | TAN/WHT | 247 | | | | |
| 141 | TWISTED PAIR | WHT/ORG | 132 | 128 | TWISTED PAIR | WHT/ORG | 140 | 115 | TWISTED PAIR | WHT/ORG | 145 | 102 | TWISTED PAIR | WHT/ORG | 216 | | | | |
| 160 | | ORG/WHT | 164 | 173 | | ORG/WHT | 172 | 186 | | ORG/WHT | 177 | 199 | | ORG/WHT | 248 | | | | |
| 140 | TWISTED PAIR | WHT/YEL | 133 | 127 | TWISTED PAIR | WHT/YEL | 141 | 114 | TWISTED PAIR | WHT/YEL | 146 | 101 | TWISTED PAIR | WHT/YEL | 217 | | | | |
| 161 | | YEL/WHT | 165 | 174 | | YEL/WHT | 173 | 187 | | YEL/WHT | 178 | 200 | | YEL/WHT | 249 | | | | |
| 139 | TWISTED PAIR | TAN/PNK | 134 | 126 | TWISTED PAIR | TAN/PNK | 202 | 113 | TWISTED PAIR | TAN/PNK | 147 | 112 | TWISTED PAIR | TAN/PNK | 209 | | | | |
| 162 | | PNK/TAN | 166 | 175 | | PNK/TAN | 234 | 188 | | PNK/TAN | 179 | 189 | | BRN/TAN | 241 | | | | |
| 138 | TWISTED PAIR | TAN/BRN | 196 | 125 | TWISTED PAIR | TAN/BRN | 203 | 111 | TWISTED PAIR | TAN/BRN | 210 | 110 | TWISTED PAIR | TAN/BRN | 242 | | | | |
| 163 | | BRN/TAN | 228 | 176 | | BRN/TAN | 235 | 190 | | ORG/TAN | 242 | 111 | | ORG/TAN | 242 | | | | |
| 137 | TWISTED PAIR | TAN/ORG | 197 | 124 | TWISTED PAIR | TAN/ORG | 204 | 110 | TWISTED PAIR | TAN/YEL | 211 | 110 | TWISTED PAIR | TAN/YEL | 211 | | | | |
| 164 | | ORG/TAN | 229 | 177 | | ORG/TAN | 236 | 191 | | YEL/TAN | 243 | 110 | | YEL/TAN | 243 | | | | |
| 136 | TWISTED PAIR | TAN/YEL | 198 | 123 | TWISTED PAIR | TAN/YEL | 205 | | | | | | | | | | | | |
| 165 | | YEL/TAN | 230 | 178 | | YEL/TAN | 237 | | | | | | | | | | | | |

CUSTOMER DRAWING - CUSTOMER DRAWING - CUSTOMER DRAWING

THE INFORMATION CONTAINED HEREIN IS THE EXCLUSIVE PROPERTY OF VIRGINIA PANEL CORPORATION AND IS SUBMITTED FOR USE BY THE CUSTOMER ONLY. THE DATA SHALL NOT BE DUPLICATED, USED, OR DISCLOSED IN WHOLE OR IN PART FOR ANY PURPOSE OTHER THAN TO MAINTAIN THE EQUIPMENT PROVIDED.

| | | | |
|--------|-----------|----------------------|--------------|
| SIZE | CAGE CODE | DWG. NO. | REV |
| C | 18117 | 540105020X05 | F |
| SCALE: | NONE | 540105020105 2/18/03 | SHEET 2 OF 2 |

DO NOT SCALE DRAWING

D

C

B

A

D

C

B

A

4

3

2

1

4

3

2

1