

DO NOT SCALE DRAWING

THE INFORMATION CONTAINED HEREIN IS THE EXCLUSIVE PROPERTY OF VPC AND IS PERMITTED FOR USE BY THE CUSTOMER ONLY. THE DATA SHALL NOT BE DUPLICATED, USED, OR DISCLOSED IN WHOLE OR IN PART FOR ANY PURPOSE OTHER THAN TO MAINTAIN THE EQUIPMENT PROVIDED. CONSULT WITH VPC ENGINEERING IF MORE DETAIL IS REQUIRED.

REV	DESCRIPTION	DATE	ENGINEER
A	ORIGINAL RELEASE - ECN# 13080	12/13/2022	K JOHNSON

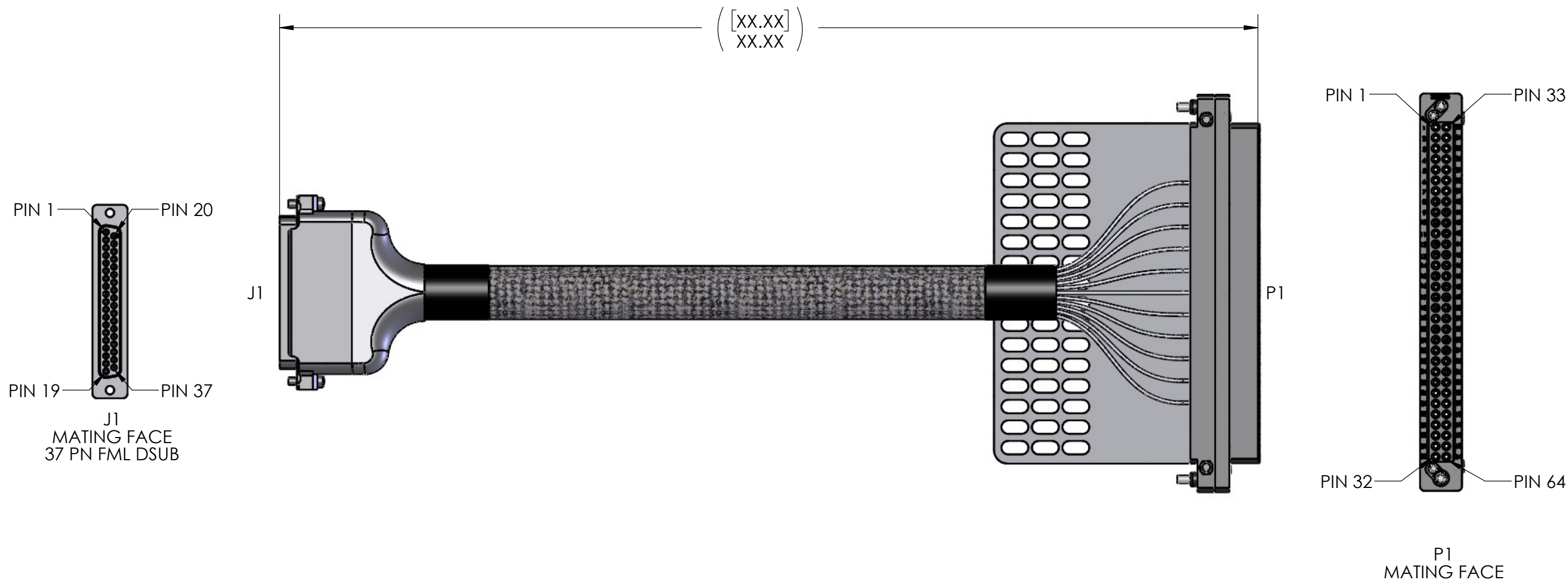

MATING MODULE: 510108101 (QTY. 1)
MATING PATCHCORDS: 7-103934000-036 (QTY. 37)

1. FOR MORE INFORMATION VISIT VPC.COM

NOTES:

VPC P/N P/N WHERE X =	LENGTH XX.XX"	CUSTOMER DRAWING	
1	20.00" [508]	 CBA, RCV, 37-PIN FML DSUB 1000V	
2	36.00" [914]		
6	48.00" [1219]		
9	60.00" [1524]		
5	72.00" [1829]		
<small>RELATIVE CONNECTOR POSITIONS AND WIRE ROUTING ARE GENERIC AND MAY VARY WITH PINOUT</small> DIMENSIONS ARE SHOWN AS: [MILLIMETERS] INCHES		DWG.NO. 540119030X01	REV A
SIZE B	SCALE NONE	CAGE CODE 18117	SHEET 1 OF 2

Run #	From Location (Conn - Pin)	From Contact	Wire AWG	Wire/Patchcord P/N	Wire Color	To Location (Conn-Pin)	To Contact
1	P1-1	610110101	22 AWG	7-104934546-XXX	WHT	J1-1	960038
2	P1-2	610110101	22 AWG	7-104934546-XXX	WHT	J1-2	960038
3	P1-3	610110101	22 AWG	7-104934546-XXX	WHT	J1-3	960038
4	P1-4	610110101	22 AWG	7-104934546-XXX	WHT	J1-4	960038
5	P1-5	610110101	22 AWG	7-104934546-XXX	WHT	J1-5	960038
6	P1-6	610110101	22 AWG	7-104934546-XXX	WHT	J1-6	960038
7	P1-7	610110101	22 AWG	7-104934546-XXX	WHT	J1-7	960038
8	P1-8	610110101	22 AWG	7-104934546-XXX	WHT	J1-8	960038
9	P1-9	610110101	22 AWG	7-104934546-XXX	WHT	J1-9	960038
10	P1-10	610110101	22 AWG	7-104934546-XXX	WHT	J1-10	960038
11	P1-11	610110101	22 AWG	7-104934546-XXX	WHT	J1-11	960038
12	P1-12	610110101	22 AWG	7-104934546-XXX	WHT	J1-12	960038
13	P1-13	610110101	22 AWG	7-104934546-XXX	WHT	J1-13	960038
14	P1-14	610110101	22 AWG	7-104934546-XXX	WHT	J1-14	960038
15	P1-15	610110101	22 AWG	7-104934546-XXX	WHT	J1-15	960038
16	P1-16	610110101	22 AWG	7-104934546-XXX	WHT	J1-16	960038
17	P1-17	610110101	22 AWG	7-104934546-XXX	WHT	J1-17	960038
18	P1-18	610110101	22 AWG	7-104934546-XXX	WHT	J1-18	960038
19	P1-33	610110101	22 AWG	7-104934546-XXX	WHT	J1-19	960038
20	P1-34	610110101	22 AWG	7-104934546-XXX	WHT	J1-20	960038
21	P1-35	610110101	22 AWG	7-104934546-XXX	WHT	J1-21	960038
22	P1-36	610110101	22 AWG	7-104934546-XXX	WHT	J1-22	960038
23	P1-37	610110101	22 AWG	7-104934546-XXX	WHT	J1-23	960038
24	P1-38	610110101	22 AWG	7-104934546-XXX	WHT	J1-24	960038
25	P1-39	610110101	22 AWG	7-104934546-XXX	WHT	J1-25	960038
26	P1-40	610110101	22 AWG	7-104934546-XXX	WHT	J1-26	960038
27	P1-41	610110101	22 AWG	7-104934546-XXX	WHT	J1-27	960038
28	P1-42	610110101	22 AWG	7-104934546-XXX	WHT	J1-28	960038
29	P1-43	610110101	22 AWG	7-104934546-XXX	WHT	J1-29	960038
30	P1-44	610110101	22 AWG	7-104934546-XXX	WHT	J1-30	960038
31	P1-45	610110101	22 AWG	7-104934546-XXX	WHT	J1-31	960038
32	P1-46	610110101	22 AWG	7-104934546-XXX	WHT	J1-32	960038
33	P1-47	610110101	22 AWG	7-104934546-XXX	WHT	J1-33	960038
34	P1-48	610110101	22 AWG	7-104934546-XXX	WHT	J1-34	960038
35	P1-49	610110101	22 AWG	7-104934546-XXX	WHT	J1-35	960038
36	P1-50	610110101	22 AWG	7-104934546-XXX	WHT	J1-36	960038
37	P1-51	610110101	22 AWG	7-104934546-XXX	WHT	J1-37	960038

CUSTOMER DRAWING - CUSTOMER DRAWING - CUSTOMER DRAWING

THE INFORMATION CONTAINED HEREIN IS THE EXCLUSIVE PROPERTY OF VPC AND IS PERMITTED FOR USE BY THE CUSTOMER ONLY. THE DATA SHALL NOT BE DUPLICATED, USED, OR DISCLOSED IN WHOLE OR IN PART FOR ANY PURPOSE OTHER THAN TO MAINTAIN THE EQUIPMENT PROVIDED.

DWG.NO.		REV	
540119030X01		A	
SIZE	SCALE	CAGE CODE	SHEET
B	NONE	18117	2 OF 2

DO NOT SCALE DRAWING