

THE INFORMATION CONTAINED HEREIN IS THE EXCLUSIVE PROPERTY OF VIRGINIA PANEL CORPORATION AND IS SUBMITTED FOR USE BY THE CUSTOMER ONLY. THE DATA SHALL NOT BE DUPLICATED, USED, OR DISCLOSED IN WHOLE OR IN PART FOR ANY PURPOSE OTHER THAN TO MAINTAIN THE EQUIPMENT PROVIDED.		REV	DESCRIPTION	DATE	ENGINEER
		A	ORIGINAL RELEASE ECN # 15708	3/26/2026	E. HESS

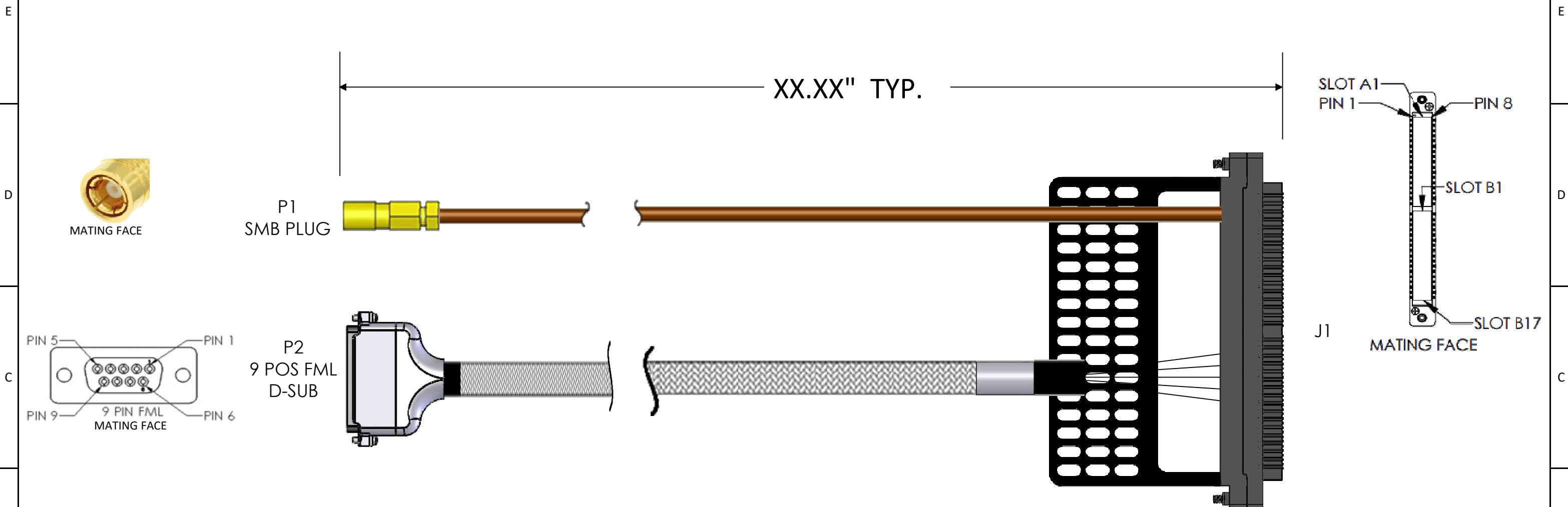

MATING COMPONENTS		
ITEM	PART NUMBER	QTY
MODULE	510171101	1
MCRCX FLYING PATCHCORD	7-361924000-036	1
VTAC MCRCX INSERT	510181104	1
QP FLYING PATCHCORD	7-121924000-036	9
VTAC/QP INSERT	510181101	3
VTAC BLANK INSERT	610151102	29

VPC P/N	LENGTH
540366010X71 WHERE X=	XX.XX"
1	20.00" [508]
2	36.00" [914]
6	48.00" [1219]
9	60.00" [1524]
5	72.00" [1829]

DIMENSION DESIGNATOR LABELS PER ES6 UNLESS OTHERWISE SPECIFIED.		TORQUE ALL SCREWS PER ES2 UNLESS OTHERWISE SPECIFIED.	
<b>VPC BREAKOUT TOLERANCES UNLESS SPECIFIED REFERENCE ENGINEERING SPECIFICATION 4</b>		DIMENSIONS ARE IN INCHES UNLESS OTHERWISE SPECIFIED.	
IF	THEN	RELATIVE CONNECTOR POSITIONS AND WIRE ROUTING ARE GENERIC AND MAY VARY WITH PINOUT	
BUNDLE SIZE IS SMALLER THAN THE CONNECTOR ENVELOPE & STRAIN RELIEF IS OFFSET	3.50 +/- 1.00	<b>TOLERANCES UNLESS SPECIFIED</b>	
		<b>NOMINAL LENGTH</b>	<b>TOLERANCE</b>
		0 - 11.99"	+1.00/-0.00
		12.00 - 59.99"	+2.00/-1.00
		60.00 - 119.99"	+4.00/-1.00
BUNDLE SIZE IS SMALLER THAN THE CONNECTOR ENVELOPE & STRAIN RELIEF IS CENTERED	4.50 +/- 1.00	120.00 - 299.99"	+6.00/-1.00
		300.00" - UP	+5 %/- 1.00
BUNDLE SIZE IS LARGER THAN THE CONNECTOR ENVELOPE	5.50 +/- 1.00		

CUSTOMER DRAWING			
<b>CBA SMB PLUG/9POS DSUB FML</b>			
DWG.NO.		REV	
<b>540366010X71</b>		<b>A</b>	
SIZE	SCALE	CAGE CODE	SHEET
B	NONE	18117	1 OF 2

2. BLANK VTAC INSERTS WILL BE LOCATED IN THE FOLLOWING SLOTS: A3-A17(15), B4-B17(14).

1. FOR APPLICATION USE AND CARE INFORMATION CONSULT VPC USERS GUIDE @ WWW.VPC.COM.

NOTES:

Run #	From Location (Conn - Pin)	From Contact	VTAC Adapter	From Signal Desc	Wire AWG	Wire/Patchcord P/N	Wire Color	To Location (Conn-Pin)	To Contact	Notes
1	J1-A1-1	610140101	510180104	MCRCX PIN1	RG316	7-362116527-XXX	TAN	P1	008550	
2	J1-B1-1	610138216	510180101	QP 1	24	7-124924546-XXX	WHT	P2-1	960038	
3	J1-B1-2	610138216	(510180101)	QP 2	24	7-124924546-XXX	WHT	P2-2	960038	
4	J1-B1-3	610138216	(510180101)	QP 3	24	7-124924546-XXX	WHT	P2-3	960038	
5	J1-B1-4	610138216	(510180101)	QP 4	24	7-124924546-XXX	WHT	P2-4	960038	
6	J1-B2-1	610138216	510180101	QP 5	24	7-124924546-XXX	WHT	P2-5	960038	
7	J1-B2-2	610138216	(510180101)	QP 6	24	7-124924546-XXX	WHT	P2-6	960038	
8	J1-B2-3	610138216	(510180101)	QP 7	24	7-124924546-XXX	WHT	P2-7	960038	
9	J1-B2-4	610138216	(510180101)	QP 8	24	7-124924546-XXX	WHT	P2-8	960038	
10	J1-B3-1	610138216	510180101	QP 9	24	7-124924546-XXX	WHT	P2-9	960038	